



CHEQUERS ELECTRONIC (CHINA) LIMITED
捷嘉電子(中國)有限公司

CERAMIC RESONATOR SPECIFICATION

PART NO.: ZTT20.00MX

<<This Product is RoHS and REACH Compliant>>

Part no.	: ZTT20.00MX
Printed on	: 5-Mar-13
Prepared	: Frankie
Ver. Ctrl.	: 030513/F
Page	: 1 of 4

Address : Room 1101-2, Mongkok Commercial Centre, 16 Argyle St.,
Mongkok, Kowloon, Hong Kong
Phone : (852) 2391-6725, (852) 2391-7306, (852) 2391-6158
Fax : (852) 2789-3205, (852) 2789-3349
Homepage : <http://www.asiansources.com/chequers.co>
E-mail : chequers@asiansources.com

1. Scope

This specification shall cover the characteristics of the ceramic resonator with ZTT20.00MX for clock oscillation circuit such as microprocessors.

2. Part no.: ZTT20.00MX

3. Electrical specification

3-1	Nominal oscillating frequency	20.00MHz
3-2	Initial tolerance	±0.5% Max.
3-3	Resonant resistance	40Ω Max.
3-4	Insulation resistance	5 x 10 ⁸ Ω Min. (at 10V DC)
3-5	Withstanding voltage	DC 100V (5 seconds) Max.
3-6	Temperature stability (-20°C to +80°C)	±0.3% Max. (from initial value)
3-6	Rating voltage - DC voltage - AC voltage	6V DC 15V p-p
3-7	Operating temperature Storage temperature	-25°C to +85°C -55°C to +95°C
3-8	Aging (for 10 years)	±0.3% Max. (from initial value)

4. Physical characteristics

	Test item	Condition of test	Performance requirement
4-1	Random drop	Resonator shall be measured after 3 times of random drops from the height of 1 meter on concrete floor.	No visible damage and the measured values shall meet Table 1.
4-2	Vibration	Resonator shall be measured after being applied with vibration (amplitude: 1.5mm, frequency: 10Hz to 55Hz) to each of the 3 perpendicular directions (X, Y, and Z) for 2 hours.	The measured values shall meet Table 1.
4-3	Resistance to soldering heat	Lead terminals are immersed up to 2mm from the resonator's body in solder bath (260°C ± 5°C for 10 seconds ± 1 second). Then the resonator shall be measured after being placed in room temperature for 1 hour.	The measured values shall meet Table 1.
4-4	Solderability	Lead terminals are immersed in solder bath (250°C ± 5°C) no closer than 2mm for 3 seconds ± 0.5 second.	Min. 95% of lead terminals' surface shall be covered with solder.
4-5	Terminal strength	After a weight of 0.5kg is applied to each terminal in axial direction for 10 seconds ± 1 second, the resonator shall be measured. After lead terminals are fixed at 2mm from the resonator's body. They shall be folded up to 90° from their axial direction and folded back to -90°, then folded back to their axial direction. The speed of folding shall be 3 seconds.	No visible damage and the measured values shall meet Table 1. No cutting off shall be visible.

Part no.	: ZTT20.00MX
Printed on	: 5-Mar-13
Prepared	: Frankie
Ver. Ctrl.	: 030513/F
Page	: 2 of 4

5. Environmental characteristics

	Test item	Condition of test	Performance requirement
5-1	High temperature	After being placed in a chamber (+85°C ± 2°C) for 500 hours ± 4 hours, the resonator is measured after being placed in room temperature for 1 hour.	The measured values shall meet Table 1.
5-2	Low temperature	After being placed in a chamber (-55°C ± 2°C) for 500 hours ± 4 hours, the resonator is measured after being placed in room temperature for 1 hour.	The measured values shall meet Table 1.
5-3	Humidity	After being placed in a chamber with a humidity of 90% to 95% RH and a temperature of +40°C ± 2°C for 500 hours ± 4 hours, the resonator is measured after being placed in room temperature for 1 hour.	The measured values shall meet Table 1.
5-4	Heat shock	After being kept at room temperature, resonator shall be placed at a temperature of -25°C ± 3°C. After 30 minutes at this temperature, the resonator is immediately placed at a temperature of 85°C ± 3°C. After another 30 minutes at this temperature, the resonator is placed under -25°C ± 2°C again. The above processes are counted as 1 cycle. After 5 cycles, the resonator shall be measured after being placed in room temperature for 1 hour.	The measured values shall meet Table 1.

Table 1

Measurements	Requirements
Oscillating frequency change	±0.3% max.
Resonant resistance	30Ω max

Part no.	: ZTT20.00MX
Printed on	: 5-Mar-13
Prepared	: Frankie
Ver. Ctrl.	: 030513/F

6. Test circuit

- 6-1 Oscillating frequency : See Figure 2.
 6-2 Equivalent circuit constants : Network Analyzer HP8751A or equivalent
 6-3 Measuring condition : Temperature: +5°C to +35°C
 Humidity: 45% to 85% RH
 If require : Temperature: +25°C ± 3°C
 Humidity: 60% ± 10% RH

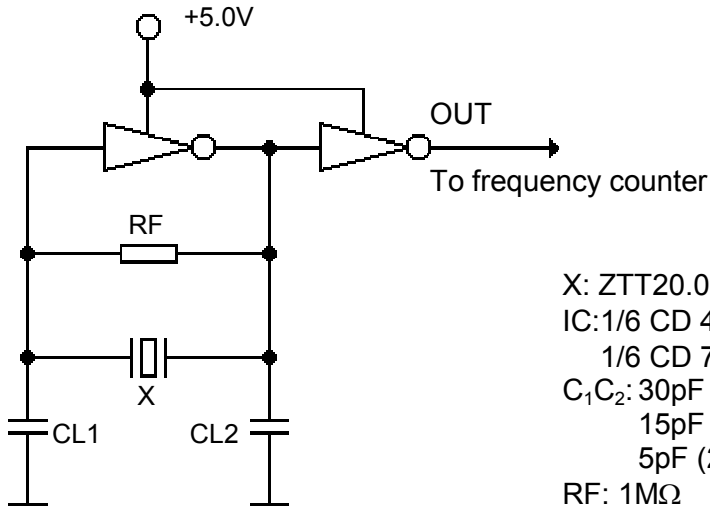

X: ZTT20.00MX
 IC: 1/6 CD 4069UBE x 2 (ZTT □□□ MT)
 1/6 CD 74HCU04P x 2 (ZTT □□□ MX)
 C_1, C_2 : 30pF (13.01MHz to 20.00MHz)
 15pF (20.01MHz to 25.99MHz)
 5pF (26.00MHz to 50.00MHz)
 RF: 1M Ω

7. Dimension of ZTT20.00MX

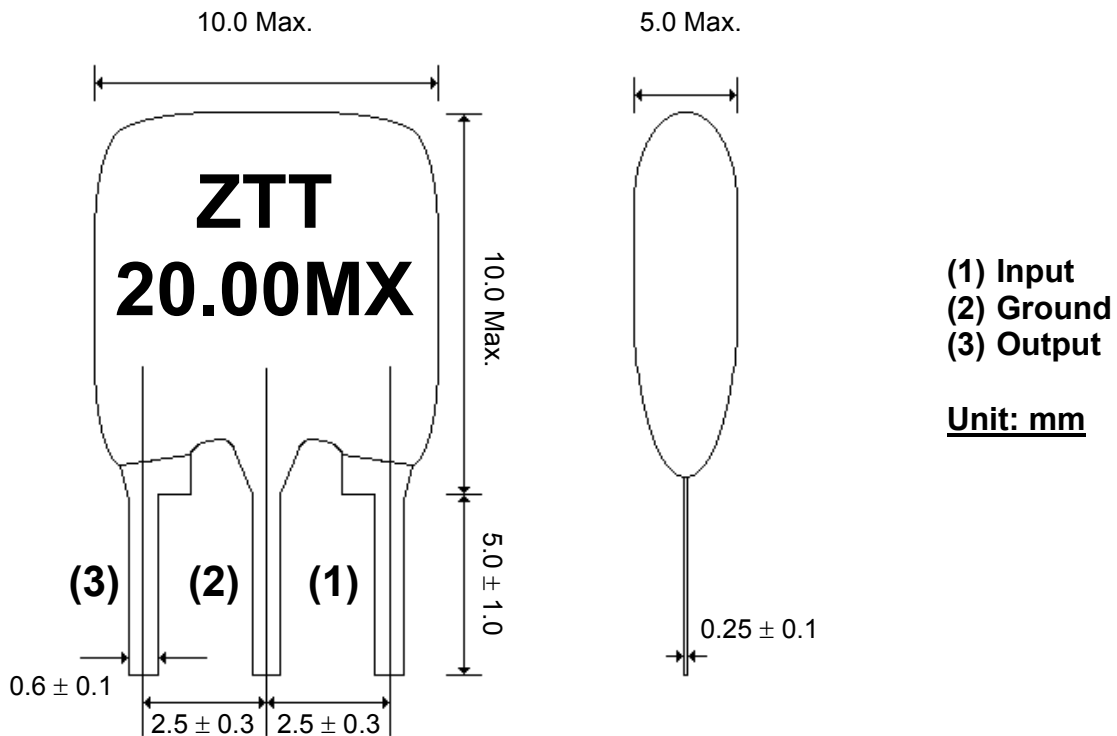

Part no.	: ZTT20.00MX
Printed on	: 5-Mar-13
Prepared	: Frankie
Ver. Ctrl.	: 030513/F
Page	: 4 of 4