



CHEQUERS ELECTRONIC (CHINA) LIMITED

捷嘉電子(中國)有限公司

CERAMIC RESONATOR SPECIFICATION

PART NO.: ZTT16.00MX

<< This Product is RoHS and REACH Compliant >>

Part no.	: ZTT16.00MX
Printed on	: 1-Aug-13
Prepared	: Frankie
Ver. Ctrl.	: 080113/F
Page	: 1 of 4

Address : Room 1101-2, Mongkok Commercial Centre, 16 Argyle St.,
Mongkok, Kowloon, Hong Kong
Phone : (852) 2391-6725, (852) 2391-7306, (852) 2391-6158
Fax : (852) 2789-3205, (852) 2789-3349
Homepage : <http://www.chequers-electronic.com>
E-mail : info@chequers-electronic.com

1. Scope

This specification shall cover the characteristics of the ceramic resonator with ZTT16.00MX for clock oscillation circuit such as microprocessors.

2. Part no.: ZTT16.00MX

3. Electrical specification

3-1	Nominal oscillating frequency	16.00MHz
3-2	Initial tolerance	±0.5% Max.
3-3	Resonant resistance	30Ω Max.
3-4	Insulation resistance	5 x 10 ⁸ Ω Min. (at 10V DC)
3-5	Withstanding voltage	DC 100V (5 seconds) Max.
3-6	Built-in capacitance	30pF ± 20%
3-6	Rating voltage - DC voltage - AC voltage	6V DC 15V p-p
3-7	Temperature stability (-25°C to +85°C) Operating temperature Storage temperature	±0.3% Max. (from initial value) -25°C to +85°C -55°C to +85°C
3-8	Aging (for 10 years)	±0.3% Max. (from initial value)

4. Physical characteristics

	Test item	Condition of test	Performance requirement
4-1	Random drop	Resonator shall be measured after 3 times of random drops from the height of 1 meter on concrete floor.	No visible damage and the measured values shall meet Table 1.
4-2	Vibration	Resonator shall be measured after being applied with vibration (amplitude: 1.5mm, frequency: 10Hz to 55Hz) to each of the 3 perpendicular directions (X, Y, and Z) for 2 hours.	The measured values shall meet Table 1.
4-3	Resistance to soldering heat	Lead terminals are immersed up to 2mm from the resonator's body in solder bath (260°C ± 5°C for 10 seconds ± 1 second). Then the resonator shall be measured after being placed in room temperature for 1 hour.	The measured values shall meet Table 1.
4-4	Solderability	Lead terminals are immersed in solder bath (250°C ± 5°C) for 2 seconds ± 0.5 second.	Min. 95% of lead terminals' surface shall be covered with solder.
4-5	Terminal strength	After a weight of 0.5kg is applied to each terminal in axial direction for 10 seconds ± 1 second, the resonator shall be measured. After lead terminals are fixed at 2mm from the resonator's body. They shall be folded up to 90° from their axial direction and folded back to -90°, then folded back to their axial direction. The speed of folding shall be 3 seconds.	No visible damage and the measured values shall meet Table 1. No cutting off shall be visible.

Part no.	:	ZTT16.00MX
Printed on	:	1-Aug-13
Prepared	:	Frankie
Ver. Ctrl.	:	080113/F
Page	:	2 of 4

5. Environmental characteristics

	Test item	Condition of test	Performance requirement
5-1	High temperature	After being placed in a chamber (+85°C ± 5°C) for 500 hours, the resonator is measured after being placed in room temperature for 1 hour.	The measured values shall meet Table 1.
5-2	Low temperature	After being placed in a chamber (-25°C ± 5°C) for 500 hours, the resonator is measured after being placed in room temperature for 1 hour.	The measured values shall meet Table 1.
5-3	Humidity	After being placed in a chamber with a humidity of 90% to 95% RH and a temperature of +40°C ± 2°C for 96 hours ± 4 hours, the resonator is measured after being placed in room temperature for 1 hour.	The measured values shall meet Table 1.
5-4	Heat shock	After being kept at room temperature, resonator shall be placed at a temperature of -25°C. After 30 minutes at this temperature, the resonator is immediately placed at a temperature of 85°C. After another 30 minutes at this temperature, the resonator is placed under -25°C again. The above processes are counted as 1 cycle. After 5 cycles, the resonator shall be measured after being placed in room temperature for 1 hour.	The measured values shall meet Table 1.

Table 1

Measurements	Requirements
Oscillating frequency change	$\Delta F / F_{osc} \leq 0.3\% \text{ max.}$
Resonant resistance	$\Delta R_o \leq 5\Omega$

Part no.	: ZTT16.00MX
Printed on	: 1-Aug-13
Prepared	: Frankie
Ver. Ctrl.	: 080113/F
Page	: 3 of 4

6. Test circuit

- 6-1 Oscillating frequency : See Figure 2.
 6-2 Equivalent circuit constants : Network Analyzer HP8751A or equivalent
 6-3 Measuring condition : Temperature: +5°C to +35°C
 Humidity: 45% to 85% RH
 If require : Temperature: +25°C ± 3°C
 Humidity: 60% ± 10% RH

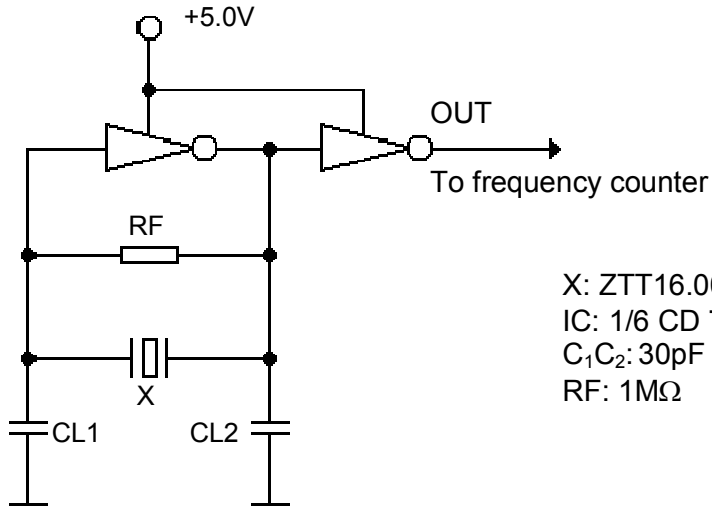

X: ZTT16.00MX
 IC: 1/6 CD 74HCU04P x 2 (ZTT □□□ MX)
 C₁C₂: 30pF
 RF: 1MΩ

7. Dimension of ZTT16.00MX

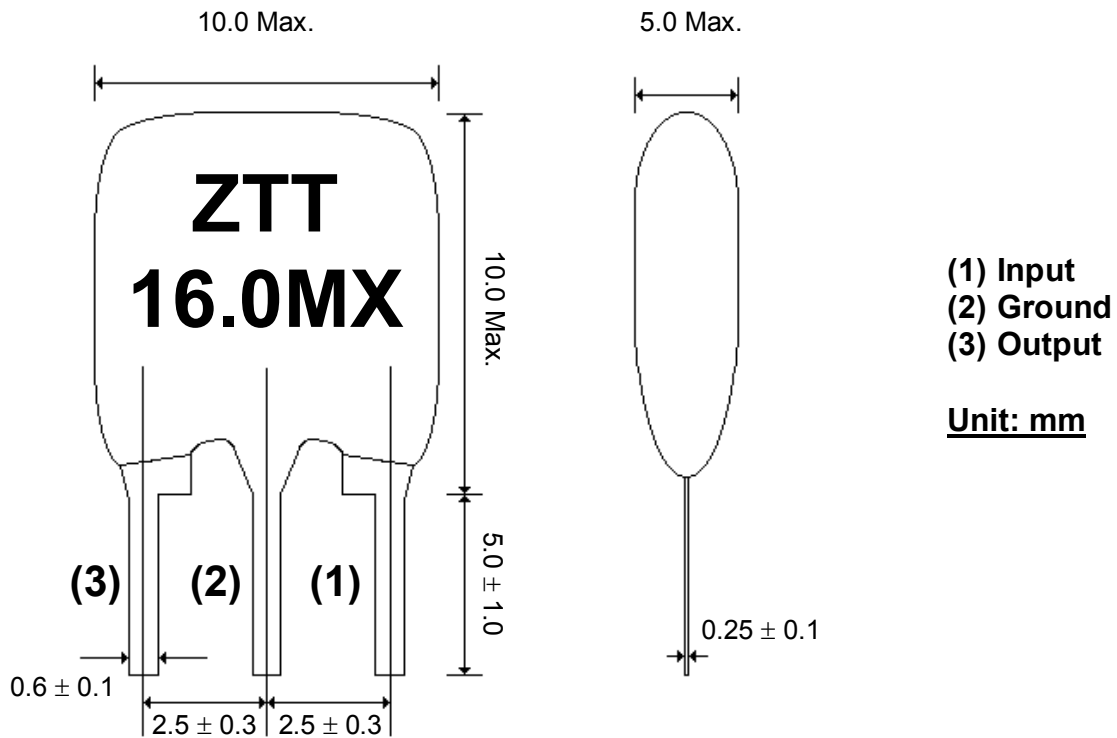

Part no.	: ZTT16.00MX
Printed on	: 1-Aug-13
Prepared	: Frankie
Ver. Ctrl.	: 080113/F
Page	: 4 of 4