



Electrochemical Gas Detection Module

User's Manual V1.1
(Model: ZE03-CO)

Issue Date 2024-12-25

Zhengzhou Winsen Electronics Technology Co., Ltd

Statement

This manual copyright belongs to Zhengzhou Winsen Electronics Technology Co., LTD. Without the written permission, any part of this manual shall not be copied, translated, stored in database or retrieval system, also can't spread through electronic, copying, record ways.

Thanks for purchasing our product. In order to let customers use it better and reduce the faults caused by misuse, please read the manual carefully and operate it correctly in accordance with the instructions. If users disobey the terms or remove, disassemble, change the components inside of the sensor, we shall not be responsible for the loss.

The specific such as color, appearance, sizes ...etc., please in kind prevail.

We are devoting ourselves to products development and technical innovation, so we reserve the right to improve the products without notice. Please confirm it is the valid version before using this manual. At the same time, users' comments on optimized using way are welcome.

Please keep the manual properly, in order to get help if you have questions during the usage in the future.

Zhengzhou Winsen Electronics Technology CO., LTD

Electrochemical Detection Module ZE03

ZE03 is a general-purpose and high-performance electrochemical module. It uses three electrodes, electrochemical gas sensor and high-performance micro-processor. By installing different gas sensor, the module could detect relevant gas. It has the digital output and analog voltage output at the same time which facilitates the usage and calibration and shorten the development period. It is a combination of mature electrochemical detection principle and sophisticated circuit design, to meet customers' different detection needs.

Features

High sensitivity & high resolution
 Small size and low power consumption
 UART and analog voltage output
 Good stability and excellent anti-interference ability



Main Application

Portable and fixed gas detector, various gas detection equipment and occasion.

Technical Parameters

Model No.	ZE03-CO
Target Gas	CO
Measurement Range	Refer table 2.
Working Voltage	DC 5±0.1V
Working Current	< 10 mA
Output Data	UART Output (TTL electrical level,3V)
	Analog Voltage (refer table2. for sensor original amplifying signal)
Working Life	2 years (in clean air)
Operating Environment	Temp.: -20~50°C
	Humidity.: 15%~90%RH (no condensation)
Storage Environment	Temp.: -20~50°C
	Humidity.: 15%~90%RH (no condensation)
Size	∅23.3mm*31.2mm(diameter*height)
Weight	O2: <25g Others: <15g

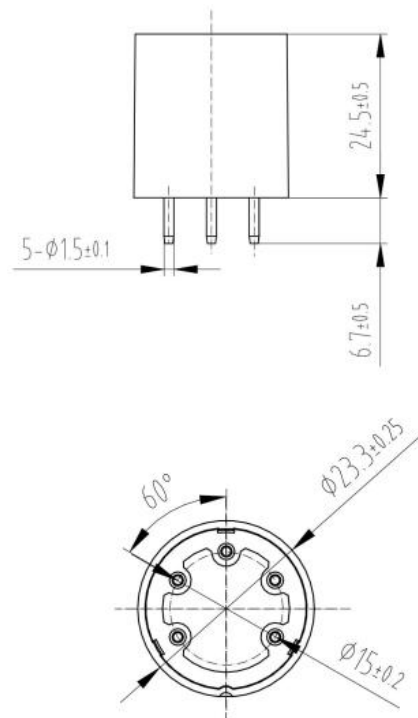

Fig1. Structure view from side and bottom

(unit is mm)

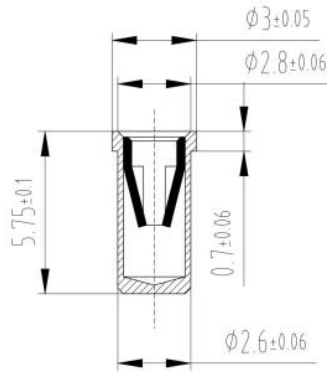

Fig2. Socket size for module (from side, unit is mm)

Detection range and signal output Table 2

No.	Gas Code	Detected Gas	Range	Resolution	Voltage output range	Response time(T90)
1	0x04	CO	(0-1000)ppm	1ppm	(0.6-3) V	≤30S

NOTE. 1.Table2 shows the normal detection range, other ranges could be customized.

Such as:

- ZE03-CO Range: 0-500ppm, Resolution: 1ppm
- Range: 0-500.0ppm, Resolution:0.1ppm
- Range: 0-200ppm, Resolution:1ppm
- Range: 0-200.0ppm, Resolution:0.1ppm
- Range: 0-200.00ppm, Resolution:0.01ppm
- Range: 0-100.0ppm, Resolution:0.1ppm

2.Left side value of detection range (zero point) is corresponding to left side value of voltage output range. BUT right side value of detection(max detection value) is **NOT** corresponding to the right side value of voltage output range.

Pin definition Table3.

GND	Ground
VCC	Power supply
VO	Original Voltage output
RXD	Series port input
TXD	Series port output

Fig3.Bottom view

The meaning of VO (Vout) : It means original voltage (linear) after amplifying circuit, rather than concentration value of current target gas in environment. If choose this output way, users need to know the zero voltage Vout0 and test voltage Vout1 which can be shown in the *ZE03 module inspection record* (if users choose UART way, this document is not needed. This document is not supplied by default). Users can calculate gas concentration of current target gas in environment based on Vout0 and Vout1.

Take ZE03-CO for example: zero voltage Vout0 = 0.6 V, its corresponding concentration N1=0ppm; in 200ppm CO gas, Vout1=0.9V, its corresponding concentration N2=200ppm, If the current voltage Voutx=1.2V, then the current CO concentration:

$$N_{outX} = N1 + \frac{V_{outX} - V_{out1}}{V_{out2} - V_{out1}} * (N2 - N1) = 0 + \frac{1.2 - 0.6}{0.9 - 0.6} * (200 - 0) = 400\text{ppm}$$

Communication Protocol

1.General Settings

Baud Rate	9600
Data Bits	8
Stop Bits	1
Parity	None

2.Communication Specification

The default communication type is active upload and it sends gas concentration once every other second (the concentration is 16 hexadecimal). If you want to switch to Q&A mode, please send 0x78 command, to change communication mode to 0x04(Q&A mode), then current concentration will be returned by module after it receiving 0x86 command (reading concentration), suggested communication cycle is 1s.

3.Communication Commands

The default mode is active upload mode, the sensor will send gas concentration actively as follow without sending any command by users. **Table5.**

Receive	0	1	2	3	4	5	6	7	8
	Start byte	Command	Concentration High byte	Concentration Low byte	Gas No	number of decimal	reserved	reserved	Check sum
	0xFF	0x86	0x00	0xD1	0x05	0x01	0x00	0x00	0xA3
EXP.	FF 86 00 D1 05 01 00 00 A3 (Take O2 for example, its concentration is 20.9% in air)								

gas concentration=(High byte*256+Low byte)*resolution.

Please note in the calculation formula, the High byte and Low byte means the decimalism value changed from hexadecimal.

If number of decimal is 0, resolution is 1ppm; number of decimal is 1, resolution is 0.1ppm; number of decimal is 2, resolution is 0.01ppm.

0X78—To modify the communication mode (0x03 is active upload mode, 0x04 is Q&A mode) **Table6.**

	0x78	To change communication mode							
Send	0	1	2	3	4	5	6	7	8
	Start Byte	Address	Command	Communication Mode	reserved	reserved	reserved	reserved	Check sum
	0xFF	0x01	0x78	0x04	0x00	0x00	0x00	0x00	0x83
EXP.	FF 01 78 04 00 00 00 00 83 (send this command to switch to Q&A mode)								
Receive	0	1	2	3	4	5	6	7	8
	Start Byte	Command	Return	reserved	reserved	reserved	reserved	reserved	Check sum
	0xFF	0x78	Success: 0x01 Failure: 0x00	0	0	0	0	0	0x87 0x88
EXP	FF 78 01 00 00 00 00 00 87 (If users received the data, it means switch successfully)								

If users want to switch to active upload mode, send FF 01 78 **03** 00 00 00 00 84(hexadecimal).

0x86 — To read the concentration value (This command is needed just under Q&A mode.) Table7.

1	0x86	To read concentration							
Send	0	1	2	3	4	5	6	7	8
	Start Byte	Address	Command	reserved	reserved	reserved	reserved	reserved	Checksum
	0xFF	0x01	0x86	0x00	0x00	0x00	0x00	0x00	0x79
EXP.	FF 01 86 00 00 00 00 00 79								
Receive	0	1	2	3	4	5	6	7	8
	Start Byte	Command	Concentration High byte	Concentration Low byte	Gas No.	number of decimal	reserved	reserved	Checksum
	0xFF	0x86	0x00	0xD1	0x05	0x01	0x00	0x00	0xA3
EXP.	FF 86 00 D1 05 01 00 00 A3 (Take O2 for example, its concentration is 20.9%vol in air)								

gas concentration=(High byte*256+Low byte)*resolution

Please note that in the calculation formula, the High byte and Low byte means the decimalism value changed from hexadecimal.

4.Checksum and calculation

/******

* Function Name: ucharFucCheckSum (uchar *i,ucharIn)

* Functional description: checksum 【Non(sending/receiving commend Byte1+Byte2+...Byte7) +1】

*Function instruction: add from first digit to penult and then do negation and plus one(number of digits must >2)

*****/

```
unsigned char FucCheckSum(unsigned char *i,unsigned char In)
```

```
{
    unsigned char j,tempq=0;
    i+=1;
    for(j=0;j<(In-2);j++)
    {
        tempq+=*i;
        i++;
    }
    tempq=(~tempq)+1;
    return(tempq);
}
```

Cautions

1. Please do not take away or plug the sensor in the module.
2. It is prohibited to weld the pins of the module. The matched sockets could be welded.
3. Sensor shall avoid organic solvent, coatings, medicine, oil and high concentration gases.
4. Excessive impact or vibration should be avoided.
5. Please keep the modules warming up for at least 5 minutes when first using. 24 hours aging time are suggested if power off for long time.
6. Please do not use the modules in systems which related to human being's safety.
7. Please do not use the modules in strong air convection environment.
8. Please do not expose the modules in high concentration organic gas for a long time.
9. Returned data of module serial port is real-time concentration of current target gas in environment, If you don't have standard gas, please do not use standard command, for it will cause calibrated data is clear away and returned data of serial port is not accurate.
10. To judge whether module communication is normal, it is advisable to use tools that can change USB to TTL(communication level 3V), debug assistant software via serial port, and determine it by communication protocol.
11. When choosing module, users should choose products of different applications and ranges. If there is no special requirement, products will use conventional range.

Zhengzhou Winsen Electronics Technology Co., Ltd

Add: No.299, Jinsuo Road, National Hi-Tech Zone,
Zhengzhou 450001 China

Tel: +86-371-67169097/67169670

Fax: +86-371-60932988

E-mail: sales@winsensor.com

Website: www.winsen-sensor.com

