

WEALTH METAL FACTORY LTD. 同發寶工業製品有限公司		文件编号	SF-SP-3217g
SPECIFICATION 规格书		发布日期	2012年10月26日
		第 A 版	第1页 共3页
MODEL NO. 产品名称 : TD-19XA			
DRAWN 制订		陈丽冰	APPD. 审批 
1. RATING (額定值) : DC 12V 50mA			
2. ELECTRICAL CHARACTERISTICS (電氣性能規格)			
ITEM 項目	TEST CONDITIONS 測試条件		PERFORMANCE 规格
2.1	CONTACT RESISTANCE 接触电阻	MEASURED AT 1KH ₂ SMALL CURRENT (100mA OR LESS) 在1KH ₂ 微小电流(100mA 以下)测试。	100 mΩ MAX. 100 毫歐以下。
2.2	INSULATION RESISTANCE 絕緣电阻	APPLY A VOLTAGE OF 100V DC SHALL BE APPLIED FOR 1 MIN AFTER WHICH MEASUREMENT BE MADE: (1) BETWEEN BODY AND TERMINAL. (2) BETWEEN TERMINALS. 輸入100V DC 電壓1分鐘,按以下接觸方法測試: (1) 外殼與排腳之間. (2) 端子之間.	100 MΩ MIN. 100 兆歐以上。
2.3	DIELECTRIC STRENGTH 耐電壓	AC 250V rms (50-60Hz) FOR 1 MIN TRIP CURRENT: 0.5 mA (1) BETWEEN TERMINALS. (2) BETWEEN INDIVIDUAL TERMINAL AND FRAME. 輸入AC 250V (50-60Hz) 電壓,1分鐘感度電流為0.5mA,按以下接觸方法測試: (1) 排腳相互之間 (2) 排腳與外殼之間	WITHOUT DAMAGE TO PARTS ARCING OR BREAKDOWN ETC. 沒有絕緣破壞等異常。
3. MECHANICAL CHARACTERISTICS (機械性能規格)			
ITEM 項目	TEST CONDITIONS 測試條件		PERFORMANCE 规格
3.1	OPERATING FORCE 作動力		見第三頁
3.2	TERMINAL STRENGTH 端子強度	A STATIC LOAD OF 300gf SHALL BE APPLIED TO THE TERMINAL FOR 1 MIN. IN ANY DIRECTION 在排腳前端任意一個方向加300gf 力度測試,時間為1分鐘。	MECHANICAL AND ELECTRICAL CHARACTERISTICS SHALL BE SATISFIED WITHOUT DAMAGE OR EXCESSIVE LOOSENESS OF ACTUATOR. 在端子中沒有裂開、鬆動等異常, 滿足于機械、電器性能。

WEALTH METAL FACTORY LTD. 同發寶工業製品有限公司		文件编号	SF-SP-3217g
		发布日期	2012年10月26日
SPECIFICATION 规格书		第 A 版	第 2 页 共 3 页
3.3	STANDARD ATMOSPHERIC CONDITIONS 測試標準狀態	UNLESS OTHERWISE SPECIFIED. THE STANDARD RANGE OF ATMOSPHERIC CONDITIONS FOR MAKING MEASUREMENTS AND TESTS ARE AS FOLLOWS: (1) AMBIENT TEMPERATURE: 5°C TO 35°C (2) RELATIVE HUMIDITY : 45% TO 85% (3) AIR PRESSURE : 80Kpa TO 106Kpa 在沒有指定的情況下測試溫度、濕度、氣壓如下: (1) 溫度為 5°C~35°C. (2) 濕度為 45%~85%. (3) 氣壓為 80Kpa~106Kpa.	
3.4	PRACTICAL TEMPERATURE RANG 使用溫度範圍	-16°C~+60°C. 在-16°C~+60°C溫度內使用.	
4. DURABILITY (耐久性)			
ITEM 項目		TEST CONDITIONS 測試条件	PERFORMANCE 规格
4.1	LIFE TEST 壽命試驗	WITHOUT LOAD: AN ACTUATOR SHALL BE SUBJECT TO 20,000 CYCLES AT A SPEED OF 60 CYCLES FOR 1 MIN. 無負荷: 操作者以每分鐘 60 次的頻率作 20,000 回之無負荷測試.	(1) CONTACT RESISTANCE SHALL BE 200mΩ MAX. (2) MECHANICAL AND ELECTRICAL CHARACTERISTICS SHALL BE SATISFIED. (1) 接觸電阻不能超于 200mΩ。 (2) 其它、滿足于機械、電器性能。
4.2	HEAT TEST 耐熱試驗	THE JACK SHALL BE STORED AT A TEMPERATURE OF 85±2°C FOR 96 HOURS. AND THEN IT SHALL BE SUBJECTED TO THE CONTROLLED RECOVERY CONDITIONS FOR 1 HOUR AFTER WHICH MEASUREMENT SHALL BE MADE. 放置在溫度 85±2°C 中測試 96 小時後,再將放置在常溫常濕的環境中 1 小時後進行測試。	
4.3	COLD TEST 耐冷試驗	THE JACK SHALL BE STORED AT A TEMPERATURE OF -25±3°C FOR 96 HOURS. AND THEN IT SHALL BE SUBJECTED TO THE CONTROLLED RECOVERY CONDITIONS FOR 1 HOUR AFTER WHICH MEASUREMENT SHALL BE MADE. 放置在溫度 -25±3°C 中 96 小時後,再將放置在常溫常濕的環境中 1 小時後進行測試。	THERE SHALL BE NO DAMAGE ON APPEARANCE. MECHANICAL AND ELECTRICAL CHARACTERISTICS SHALL BE SATISFIED. 外觀無異常,滿足于機械,電器性能。
4.4	HUMIDITY TEST 潮濕試驗	THE JACK SHALL BE STORED AT A TEMPERATURE OF 40±2°C AND A HUMIDITY OF 90% TO 96% FOR 96 Hr. THEN THE JACK SHALL BE MAINTAINED AT STANDARD ATMOSPHERIC CONDITION FOR 1 Hr FOR OTHER PROCEDURES. 放置 40±2°C 的相對濕度為 90~96% 環境中 96 小時後,再將放置在常溫常濕的環境中 1 小時後進行測試。	

WEALTH METAL FACTORY LTD. 同發寶工業製品有限公司		文件编号	SF-SP-3217g
		发布日期	2012年10月26日
SPECIFICATION 规格书		第 A 版	第 3 页 共 3 页
ITEM 项目	TEST CONDITIONS 测试条件	PERFORMANCE 规格	
4.5 SOLDERING CONDITIONS 焊錫條件	<p>(1) HAND SOLDERING: DEVICE: SOLDER IRON 手焊: 工具: 烙鐵 A. 350°C Max. 3sec. Max. B. 270°C Max. 5sec. Max.</p> <p>(2) REFLOW SOLDERING 回流焊 260°C Max. 3sec. Max.</p>	<p>THERE SHALL BE NO DAMAGE ON APPEARANCE. MECHANICAL AND ELECTRICAL CHARACTERISTICS SHALL BE SATISFIED.</p> <p>外觀無異常, 滿足于機械, 電器性能。</p>	
5.0 STORAGE ENVIRONMENT 儲存環境	<p>(1) UNDER SEALING PACK CONDITION, STORED TEMPERATURE DON'T EXCEED 30°C AND RELATIVE HUMIDITY IS 75%RH; IN THE ENVIRONMENT OF NO SUNSHINE DIRECT AND NO CORROSIVE GAS, THE STORED TIME OUGHT TO BE THREE MONTHS BUT WITHIN SIX MONTHS AT MOST.</p> <p>(2) WITHOUT SEALING PACK CONDITION, STORED TEMPERATURE DON'T EXCEED 30°C AND RELATIVE HUMIDITY IS 75%RH; IN THE ENVIRONMENT OF NO SUNSHINE DIRECT AND NO CORROSIVE GAS, THE STORED TIME SHOULDN'T EXCEED 48H.</p> <p>(3) DON'T EXCESSIVE OVERLAP OR OVERSTOCKING WHEN KEEPING THIS GOODS, IN CASE OF DAMAGE.</p> <p>(1) 密封包裝狀態下, 儲存溫度為≤30°C, 相對濕度 75%RH, 無陽光直射, 無腐蝕性氣體的環境中, 儲存時間為3個月, 最長不宜超過6個月。</p> <p>(2) 無密封包裝狀態下, 儲存溫度為≤30°C, 相對濕度 75%RH, 無陽光直射, 無腐蝕性氣體的環境中, 儲存時間最長不宜超過48小時。</p> <p>(3) 保存時應注意物品不能過量重疊、積壓, 以免損壞。</p>		
		CODE	0/FORCE
		Y	190gf±50gf
		Z	250gf±100gf

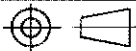

CAD FILE:

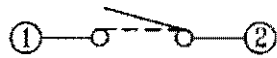

SCHEMATIC

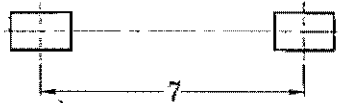

P.C.B. LAYOUT
TOP VIEW

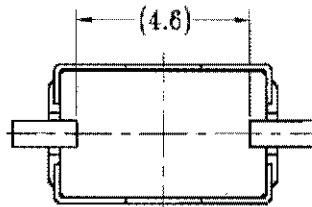
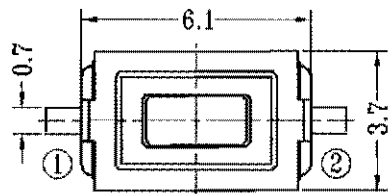

VIEW K

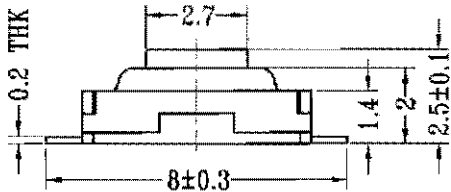

K

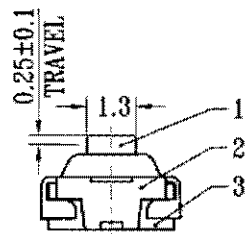

SCALE 3:2

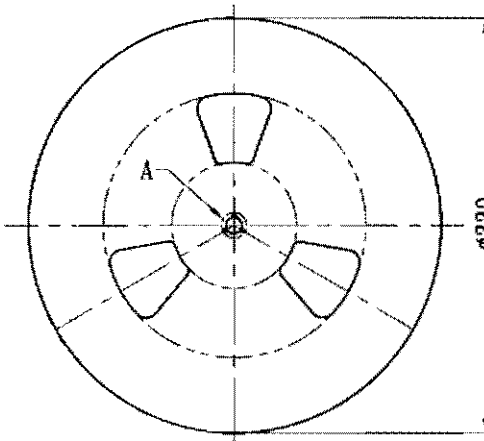
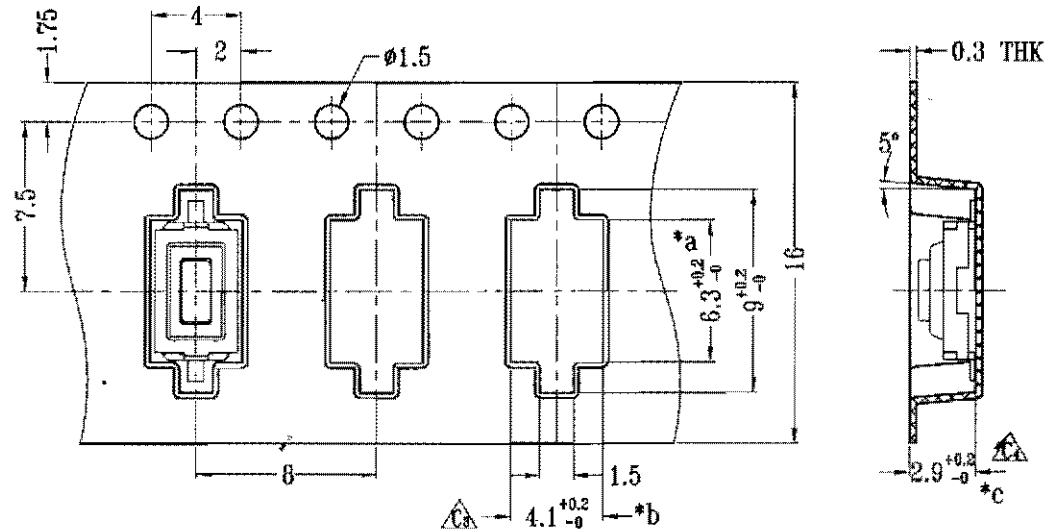

SCALE 1:30

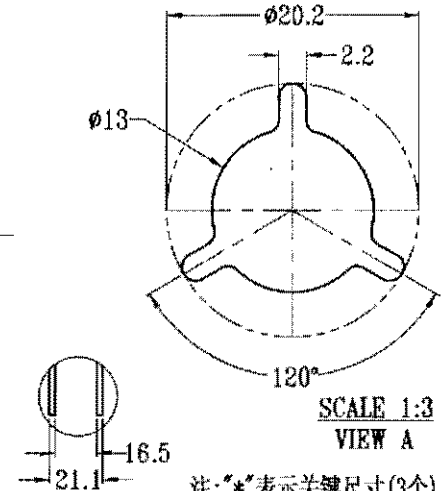

SCALE 1:3
VIEW A

注:*表示关键尺寸(3个)

NO.	PARTS	MATERIALS	Q'TY	FINISH	TOLERANCE UNLESS SPECIFIED	ISSUE	DATE	DESCRIPTIONS OF REVISION	APPD.	
8										
7										
6	TD19XA TAPE & REEL	PS	1	CLEAR	WITHIN 1.5mm : ±0.1mm	D	11-Dec-2012	原尺寸为: 4 ^{+0.2} ₋₀ 原尺寸为: 2.7 ^{+0.2} ₋₀	ML	
5	SEAL PLATE	PET	1	BROWN	OVER 1.5mm : ±0.2mm	ISSUE	DATE	DESCRIPTIONS OF REVISION	APPD.	
4	CONTACT	SUS	1	Ag CLAD	TITLE : TACT SWITCH				UNIT : mm	DRWG NO.: TT-DR-TD19XA(TR)-00
3	CASE	FR52/BRASS STRIP	1	BLACK/Ag PLATED OVER Ni PLATED						
2	COVER	SUS	1	WASHING	MODEL: TD-19XA (TR)				SCALE: 5:1	DWN. 马燕秋 11-Dec-2012
1	KNOB	FR52/NYLON+F.G	1	BLUE/RED/WHITE						CHK'D 陈丽冰 11-Dec-2012
					WEALTH METAL FACTORY LTD.				APPD. ML 11-Dec-2012	