



WEALTH METAL FACTORY LTD.

同發寶工業製品有限公司



# 产品规格书

Product Specification

编号 No: WM-SP-0982

版本 Version: A

页码 page: 1 of 7

发出日期 Issued on: 10-07-2021

客户名称 Customer:

客户部件号 Customer Part No:

同發寶产品名称 Wealth Metal Product Name: HORIZONTAL SLIDE SWITCH

同發寶产品型号 Wealth Metal Item No: SK-23D15-G9

同發寶产品料号 Wealth Metal Part No: /

## 规格书确认 Specification For Approval

确认者 Approval by

签名或盖章 Signature:

日期 Date:

备注:

- 该规格书为客户与同發寶公司在产品单品技术方面的共识，其它相关数据上与该规格书不一致的内容都是无效的。  
This Product Specification is considered as the technical agreement on product between the receiving customer and Wealth Metal . Any information on the Product Catalogue which is in conflict with or different from the corresponding information of this document is considered as invalid.
- 如果顾客收到规格书后没有信息反馈而直接向我公司订货，我们将认为贵客已接受此规格书。  
If customer issue purchase orders without confirmation by signature of this specification after receipt, such confirmation will be considered as granted upon receipt of the first purchase order.
- 本产品规格书从生效日起 1 年后，如果没有订货返回或再次申请最新规格书时请作无效处理。  
If there is no order or no request for new specification after 1 year upon this specification is issued, the specification will be regarded as invalid.

若确认此规格书, 请签署此页. Please return this copy as a certification of your approval.

## 规格书更改记录 Record of Change Specification

版本 Version	修改总项 History×Count	明细 Details	日期 Date	拟制 Pred

生产地: 中国 Country of Origin: China

地址: 广东省 惠州市 惠城区 小金口办事处 小铁村大三组 93 号

Address: 93#, 3rd Group Xiaotie Village, Xiaojinkou Streets Office, Huizhou, Guangdong Province

电话 Tel: : +86 (752) - 5308688

传真 Fax: : +86 (752) -5308688-883

电子邮箱 E-Mail: sales@wealthmetal.com

网址 Website: <http://www.wealthmetal.com/>

拟制 Prepared by: 余文波

审核 Checked by

批准 Approved by:

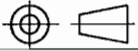

CAD FILE:

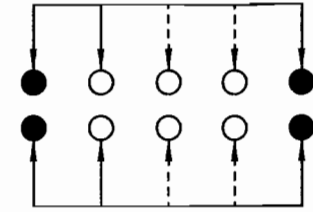
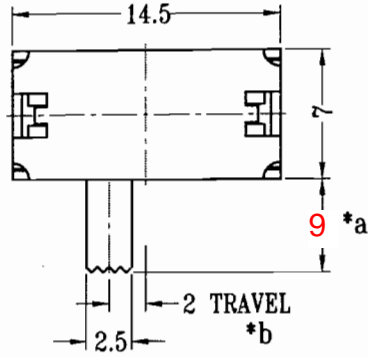

SCHEMATIC (SHORTING)

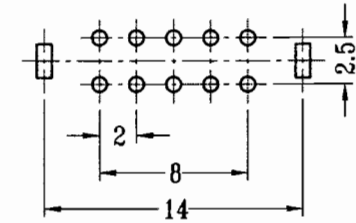
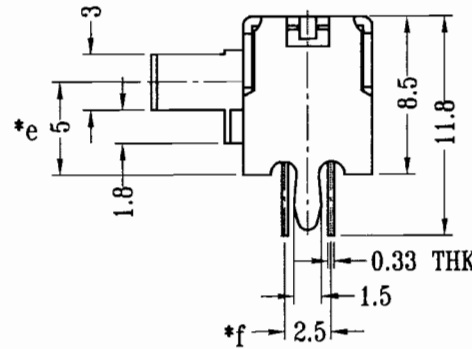
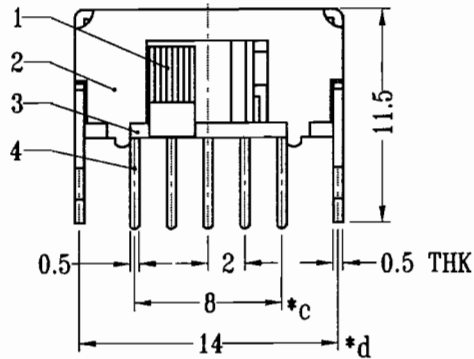

P.C.B LAYOUT  
BOTTOM VIEW

注:\*表示关键尺寸(6个).

NO.	PARTS	MATERIALS	Q'TY	FINISH	TOLERANCE UNLESS SPECIFIED						
8					WITHIN	1.5mm : ±0.1mm	A	10-Jun-2011	初版		
7					OVER	1.5mm : ±0.2mm	ISSUE	DATE	DESCRIPTIONS OF REVISION		
6	SPRING PLATE	SUS	1	NATURAL	TITLE : HORIZONTAL SLIDE SWITCH			UNIT : mm	DRWG NO.: TT-DR-SK23D15-00		
5	CONTACT CLIP	PBS C5210R-EH	2	Ag CLAD	MODEL: SK-23D15-G9			SCALE: 5:2	DWN.	卢业创	10-Jun-2011
4	TERMINAL	BRASS STRIP	10	Ag PLATED OVER Ni PLATED	WEALTH METAL FACTORY LTD.			CHK'D	10-Jun-2011	APPD.	
3	BASE	PHENOLIC RESIN	1	NATURAL				APPD.	10-Jun-2011		
2	FRAME	STEEL STRIP	1	Ni PLATED							
1	KNOB	POM	1	BLACK							

	产品型号 Product No. :	SK-23D15	版本 VER	A
	产品料号 Part No. :	/	页码 Page	2 of 7
	文件编号 File No. :	WM-SP-0982	日期 Date	10-07-2021

### 1. 一般特性 General Characteristics:

1.1 适用范围 Application:	该规格书指横柄拨动开关的一般使用范围 This specification is applied to the horizontal slide switch for general Applications .
1.2 使用温度范围 Operating Temperature Range:	-15°C到+65°C -15°C to +65°C
1.3 相对湿度 Operating Relative Humidity:	≤85%RH, +5°C到+35°C ≤85% at +5°C to +35°C
1.4 保存温度范围 Storage Temperature Range	-15° C 到 +65° C -15° C to +65° C
1.5 实验条件 Test Conditions:	若没有特别说明, 则试验大气条件如下 Unless otherwise specified, the atmospheric conditions for making measurements and tests are as follows: 环境温度 Ambient Temperature: 5-35°C 大气压力 Air Pressure: 86-106Kpa 860-1060mbar 相对湿度 Relative Humidity: 45-85%RH
1.6 接触型式 Function	2P3T
1.7 时间特性 Timing	SHORTING

### 2. 外观, 结构及尺寸 Appearance, Structure & Dimensions:

2.1 外观 Appearance:	产品外观良好, 无锈蚀、裂纹和镀层缺陷。The switch shall have good finishing, and no rust, crack or plating defects.
2.2 结构及尺寸 Structure & Dimensions:	参见产品图纸。Refer to individual product drawing.
2.3 标识 (Markings):	参见产品图纸。Refer to individual product drawing.

### 3. 额定负荷 Ratings:

3.1 额定负荷 Ratings	DC 50V 0.3A
------------------	-------------

### 4. 初始电气性能 Initial Electrical Characteristics:

项目 Item	标准 Criteria	实验方法 Test Method
4.1 接触电阻 Contact Resistance	30mΩ Max	以 1A, 5V DC 或在 1KHz±200Hz (20mV Max, 50mA Max) 采用电压降法测量 Shall be measure at 1KHz±200Hz (20mV Max, 50mA Max) or 1A, 5V DC by voltage drop method.
4.2 绝缘电阻 Insulation Resistance	100MΩ Min	在相互绝缘的所有端子之间及各端子与外壳之间加载 DC 500V, 持续时间 60±5 秒 A voltage of DC 500V shall be applied between open Terminals and between the terminal and the frame for 60±5 Sec
4.3 抗电强度 Dielectric Voltage	无击穿现象发生。 No dielectric breakdown shall occur.	在相互绝缘的所有端子之间及各端子与外壳之间加载 AC 500V (50-60Hz 泄漏电流 0.5mA, 持续时间 60±5 秒 A voltage of AC 500V (50-60HZ), 0.5mA trip current shall be applied between open terminals and between the frame and the terminal for 60±5 Sec

	产品型号 Product No. :	SK-23D15	版本 VER	A
	产品料号 Part No. :	/	页码 Page	3 of 7
	文件编号 File No. :	WM-SP-0982	日期 Date	10-07-2021

5. 机械特性 Mechanical Characteristics:

项目 Item	标准 Criteria	实验方法 Test Method									
5.1 操作力 Operating Force	(T1→T2) 250±100gf (T2→T3) 350±100gf (T3→T2) 250±100gf (T2→T1) 350±100gf	在胶柄顶端沿操作方向均匀施加静载荷, 使操作元件转换到下一动作位置 A static load shall be applied to top of knob in operating direction to change the component to the operating position									
5.2 行程 Travels	参见产品图纸 Refer to individual product drawing.	胶柄从一位置移到下一位置的距离 The distance of the knob travels from one position to then next									
5.3 端子强度 Terminal Strength	在端子中没有裂开、松动等异常, 满足于机械、电气性能. Mechanical and electrical Characteristics shall be Satisfied without damage or excessive looseness of actuator	以 300gf 静负载施加于端子末端任一方向, 保持 15 秒, 每个端子测量一次 A static load of 300gf shall be applied to the tip of terminal in a desired direction for 15 Sec. The test shall be done once per terminal									
5.4 可焊性 Solder-Ability	超过 90%的焊锡面积被焊料所覆盖 More than 90% of immersed Part shall be covered with solder	试件在下列参数条件下进行试验 Switch shall be checked after following test: (1) 焊料 Solder: Sn-3Ag-0.5Cu (2) 焊剂 Flux: Rosin Flux JIS K 5902 (3) 焊接温度: 245 ± 3°C 焊接时间: 3 ± 0.5 Sec Soldering Temperature: 245 ± 3°C Immersing Time: 3 ± 0.5 Sec									
5.5 耐焊性 Resistance to soldering heat	外观无异常、满足于机械、电气性能 There shall be no Deformation Or cracks in molded part	1. 温度及浸锡时间 Temperature and immersing time <table border="1" data-bbox="799 1361 1506 1662"> <thead> <tr> <th></th> <th>温度(°C) Temperature</th> <th>时间(S) Time</th> </tr> </thead> <tbody> <tr> <td>浸锡 Dip soldering</td> <td>260±5</td> <td>3±1</td> </tr> <tr> <td>手焊 Manual soldering</td> <td>360±10</td> <td>3±1</td> </tr> </tbody> </table> 2. 浸锡深度: 浸锡深度至基板(PCB)表面, 基板厚度为 1.6mm。 Immersion depth: Immersion depth up to the surface of the board Thickness of printed wiring board 1.6mm.		温度(°C) Temperature	时间(S) Time	浸锡 Dip soldering	260±5	3±1	手焊 Manual soldering	360±10	3±1
	温度(°C) Temperature	时间(S) Time									
浸锡 Dip soldering	260±5	3±1									
手焊 Manual soldering	360±10	3±1									

	产品型号 Product No. :	SK-23D15	版本 VER	A
	产品料号 Part No. :	/	页码 Page	4 of 7
	文件编号 File No. :	WM-SP-0982	日期 Date	10-07-2021

6. 寿命试验 Durability Characteristics:

项目 Item	标准 Criteria	实验方法 Test Method
6.1 寿命试验 Life test	实验后 After test 接触电阻: 200mΩ Max Contact resistance: 200mΩ Max 绝缘电阻: 50MΩ Min Insulation resistance: 50MΩ Min 抗电强度: AC 500V 60±5 秒 Withstand voltage AC 500V, 60±5Sec 操作力变化范围: 初始值±30% Operating force range: ±30% initial value. 开关外观及结构应无损坏 The switch shall be free from abnormalities in appearance and construction.	无负荷: 操作者以每分钟15~18 次的频率作 10,000 回之 无负荷测试. Without load: An actuator shall be subject to 10,000 cycles at a Speed of 15~18 cycles for 1 Min.

7. 耐候性能 Weather Proof Characteristics:

项目 Item	标准 Criteria	实验方法 Test Method
7.1 高温 Hot Proof		开关在 70±2℃的温控箱内保持 96 小时, 然后在正常温度和湿度下恢复 2 小时, 并在此后 1 小时内对开关进行测量 After testing at 70±2℃ for 96 hours, the switch shall be allowed to stand under normal room temperature and humidity conditions for 2 hours, and then measurement shall be made within 1 hour
7.2 低温 Cold Proof	外观无异常、满足于机械、电气性能 There shall be no Deformation Or cracks in molded part	开关在-25±3℃的温控箱内保持 96 小时, 然后在正常温度和湿度下恢复 2 小时, 并在此后 1 小时内对开关进行测量, 水滴应消失 After testing at -25±3℃ for 96 hours, the switch shall be allowed to stand under normal room temperature and humidity conditions for 2 hours, and then measurement shall be made within 1 hour, Water drops shall be eliminated
7.3 恒定湿热 Moisture Resistance		开关在 40±2℃, 90-95%RH 的温控箱内保持 96 小时, 然后在正常温度和湿度下恢复 2 小时, 并在此后 1 小时内对开关进行测量, 水滴应消失 After testing at 40±2℃, 90-95% RH for 96 hours, the switch shall be allowed to stand under normal room temperature and humidity conditions for 2 hours, and then measurement shall be made within 1 hour, Water drops shall be eliminated

	产品型号 Product No. :	SK-23D15	版本 VER	A
	产品料号 Part No. :	/	页码 Page	5 of 7
	文件编号 File No. :	WM-SP-0982	日期 Date	10-07-2021

## 8. 注意事项 Precautions for use:

### 1. 一般事项 General:

本产品主要用于自动化装置，视像装置，家用电器，信息装置及通讯装置等常用电子设备中；如果该产品要用于其它具有更高安全性及可靠性的耐久性设备中（如生命维持装置，宇宙航空装置，防灾及安全性装置）时，请确认是否合用，或者同我方了解详细情况。

The product is used mainly in electronic devices such as automotive devices, visual devices, home electrical appliances, information devices and communication settings. If the products is intended to be used for other endurance equipments requiring higher safety and reliability such as life support system, space and aviation devices, disaster and safety system, it' s necessary to make verification of conformity or contact us for the details before using.

### 2. 焊接安装 Soldering and assembly:

(1) 如果焊锡时，有施力在端子部位的话，则端子可能会变形且易出现电气性能不良。

If there is force applied on the terminal during soldering, the terminal may deform and the electrical characteristics may not be satisfied.

(2) 焊锡条件应按照实际的对应条件予以确认。

The soldering conditions should be confirmed according to the actual production environment.

(3) 焊锡工序完成后，不要尝试用溶剂或类似物品清洗开关。

Don' t try to clean the switch with a solvent or similar substance after the soldering process.

(4) 开关焊锡后，还有热量时，请不要操作开关。

Don' t operate the switch if it still has heat after soldering.

(5) 如使用水溶性助焊剂，可能会导致开关破损，因此应确保不要用这种助焊剂。

The switch might be damaged if using the water-soluble flux, so make sure not to use such kind of flux.

### 3. 安装构造，机械设计 Assembly structure and Mechanical design:

(1) 线路板上安装孔及安装图示的尺寸都须参照工程图中所建议的尺寸。

The dimensions for the holes and the pattern on PCB should refer to the recommended dimensions on the engineering drawing.

(2) 操作条件 Operating Conditions:

打键部件的许可倾斜角度为  $90 \pm 3^\circ$

The allowable inclination of keying section is  $90 \pm 3^\circ$ .

(3) 如果施超出规定值的较大重力于开关上，会导致开关破损，所以应特别小心防止开关承受超出规定值的较大重力。

The switch might be broken if there is stress stronger than the specified is given on it. Take special care not to stress the switch beyond its specification.

(4) 把本公司的产品和其它产品配合使用时，请客户确认必须适合的规格、法规或规定。另请客户自身确认本公司产品装到客户使用的系统、机械、装置上的适用性。如果想变更开关使用条件，请预先与本公司进行协商。

If the switch is being used together other products, please confirm the compatibility of the specification, laws and regulations. Please also confirm the compatibility of switch to be installed in the systems, machines and devices used by customer. If you want to change the operating conditions of the switch, please consult with us in advance.

	产品型号 Product No. :	SK-23D15	版本 VER	A
	产品料号 Part No. :	/	页码 Page	6 of 7
	文件编号 File No. :	WM-SP-0982	日期 Date	10-07-2021

#### 4. 使用环境 Operating Environment

- (1) 如果该产品常用于产生硫化气体的硫性热源周围或有汽车废气存在的地方，应特别留意，因为开关性能可能会受到影响；

If the product is always used near sulfurate hot spring where sulfide gas is generated or in a place where exhaust gas from automobiles exists, it' s necessary to pay more attention because the switch performance may be affected.

- (2) 如果在安装开关的模组内有以下所描述的部件材料，需遵循以下要求：

If the below parts or materials are used in the module where the switch is installed, directions below should be followed:

- A. 部品、橡胶材料、粘合剂、包装材料及用于装置内机械部件上的润滑油剂等，不要使用那些可能会产生硫化气体或氧化气体的材料。

For parts, rubber materials, adhesive agents, packing material and grease used for the mechanical part of the device, don' t use any material that may generate gas of sulfurization or oxidization.

- B. 当有用到磷橡胶、润滑油、粘合剂及油脂时，应使用不会产生低分子磷氧烷气体的材料，因为低分子磷氧烷气体会在开关接触部位形成二氧化磷层而引起接触不良，如有用到（如涂料剂等化学溶剂），请预先告知我方。

If silicon rubber, grease, adhesive agents and oil are used, choose the material that will not generate low molecular siloxane gas, because the low molecular siloxane gas may form silicon dioxide coat on the switch contact part, resulting of failing contact.

- (3) 不要将开关用于高湿或有沾湿可能性的环境中，因这样的环境可能会引起端子间电流泄漏。

Don' t use the switch in the environment with high humidity or other bedewing possibility, as it may cause leaking among the terminals.

- (4) 外部浸入物的影响 The effect caused by outer immersed dust:

由于该开关无密封机构，因此可能会由于外部环境中浸入的尘埃而引起接触失效，在使用该开关时，应采取防尘措施，以下是尘埃浸入的范例，使用时请注意防止：

Because the switch was designed without dust-proof structure, it may have failing contact due to the immersed dust from the outer environment. When using the switch, it' s necessary to take dust-proof actions. Examples of immersed dust, which should be prevented during the operation:

- A. 加工过程中切口处及 PCB 孔处产生碎屑，或 PCB 防护材料，（如报纸、发泡、聚苯乙烯材料等）产生的废弃物等浸入开关内。

The scraps being generated during PCB processing, or other waste from the protective material for PCB such as newspaper, foam, polystyrene materials, may immerse inside the switch.

- B. 在堆叠 PCB 时产生的助焊剂或粉末状焊剂浸入开关内。

The flux or solder powder being generated when stacking the PCB may immerse inside the switch.

#### 5. 保存方法 Storage Method:

- (1) 为防止本产品的性能劣化和耐焊性等性能受到影响，请保管在以下的条件和环境下：

In order to protect the switch performance and the soldering conditions, it should keep the switch under the following conditions:

- ① 温度  $-10^{\circ}\text{C}$  以上， $+40^{\circ}\text{C}$  以下，湿度 85% 以下的环境。



	产品型号 Product No. :	SK-23D15	版本 VER	A
	产品料号 Part No. :	/	页码 Page	7 of 7
	文件编号 File No. :	WM-SP-0982	日期 Date	10-07-2021

Temperature of -10°C to +40°C, with humidity lower than 85%RH;

- ② 避免保存在含有腐蚀性气体等的空气中。

Avoid storing in the environment containing corrosive gas;

- ③ 避免保存在日光能直射的场所。

Avoid keeping it in the location with direct sunlight.

- (2) 在不施加负重外力的包装状态下进行保管。

Store using the standard packing without exerting force.

- (3) 保存标准为 3 个月，限度为 6 个月以内，请尽早使用。打开包装后，有剩余品时，应将剩余部分以胶袋包装好以同外界隔离，请进行合适的防湿，防腐蚀气体等处理后进行保管。

The standard storage period is 3 months, with maximum up to 6 months, preferably to be used as soon as possible. After opening the package, you should put the remaining switches in a plastic bag to prevent from damp and corrosive gas.

#### 6. 其它 Others

请特别注意严格遵守以下的禁止事项及注意事项：

Please take good care to comply with the following guidelines:

- (1) 关于火灾，冒烟的禁止事项 The prohibited practices where there is fire and fume:

- ① 超过额定负荷使用时，有发生火灾的可能性，故请勿超负荷使用。

It might catch fire if the rating exceeds the specifications. Never use the switch beyond the rating.

如果有误使用、异常使用等有可能超过额定电流的话，请采取对策。如：通过设置保护电路等切断电流。

If the rating may exceed due to some abuse or abnormal usage, please take protective measures such as protective circuit to shut down the circuit.

- (2) 对于追求安全性产品的注意事项 Precautions to the products requiring special safety:

- ① 对于产品品质我司以期万全，但有可能发生寿命等故障形式，如性能劣化、短路、常开等。因此，在设计追求安全性产品的时候：“对于零件单一故障，产品会出现什么故障”。请进行事前检讨。

Though we are confident in switch quality, we can't deny the possibility that there could be failure due to inferior performance, short or open circuit. Therefore, when designing the product requiring special safety, please verify in advance what effects would show on your product in case the switch alone may fail.

- ② 准备保护电路、保护装置的系统以谋求安全。

Prepare the system with protective circuit and protective devices for safety purposes.

- ③ 准备安全备用电路，使单一的故障不会导致整体系统的失效，以确保安全性。

Prepare safety standby circuit to preclude the whole system failure that may result from specific failure.