



RUT241

INDUSTRIAL 4G eSIM™ ROUTER



Industrial & automation



Energy & utilities



Enterprise



Retail



Smart city

CONNECTIVITY

4G LTE (Cat 4), 3G, 2G

ESIM™

Seamless connectivity with eSIM™ SGP.22

WI-FI

Wireless Access Point with Hotspot functionality

RMS

For easy & convenient eSIM™ profile management

Mobile

Mobile module	4G LTE Cat 4 up to 150 DL/50 UL Mbps; 3G up to 21 DL/5.76 UL Mbps; 2G up to 236.8 DL/236.8 UL kbps
3GPP Release	Release 10/11 depending on the hardware version
eSIM*	Consumer type eSIM, profile download and removal operations, up to 7 eSIM profiles; does not include data plans
	*Feature availability varies by order code
SIM switch*	1 x 2FF SIM and 1 x eSIM, auto-switch cases: weak signal, data limit, SMS limit, roaming, no network, network denied, data connection fail
	*Feature availability varies by order code
Status	IMSI, ICCID, operator, operator state, data connection state, network type, bandwidth, connected band, signal strength (RSSI), SINR, RSRP, RSRQ, EC/IO, RSCP, data sent/received, LAC, TAC, cell ID, ARFCN, UARFCN, EARFCN, MCC, and MNC
SMS	SMS status, SMS configuration, EMAIL to SMS, SMS to EMAIL, SMS to HTTP, SMS to SMS, scheduled SMS, SMS autoreply, SMPP
USSD	Supports sending and reading Unstructured Supplementary Service Data messages
Block/Allow list	Operator block/allow list (by country or separate operators)
Multiple PDN	Possibility to use different PDNs for multiple network access and services
Band management	Band lock, Used band status display
SIM PIN code management	SIM PIN code management enables setting, changing, or disabling the SIM card's PIN
APN	Auto APN
Bridge	Direct connection (bridge) between mobile ISP and device on LAN
Passthrough	Router assigns its mobile WAN IP address to another device on LAN

Wireless

Wireless mode	802.11b/g/n (Wi-Fi 4), Access Point (AP), Station (STA)
Wi-Fi security	WPA2-Enterprise: PEAP, WPA2-PSK, WPA-EAP, WPA-PSK, WPA3-SAE, WPA3-EAP, OWE; AES-CCMP, TKIP, Auto-cipher modes, client separation, EAP-TLS with PKCS#12 certificates, disable auto-reconnect, 802.11w Protected Management Frames (PMF)
SSID/ESSID	SSID stealth mode and access control based on MAC address
Wi-Fi users	Up to 50 simultaneous connections
Wireless Connectivity Features	Wireless mesh (802.11s), fast roaming (802.11r), Relayd, BSS transition management (802.11v), radio resource measurement (802.11k)
Wireless MAC filter	Allowlist, blocklist
Wireless QR code generator	Once scanned, a user will automatically enter your network without needing to input login information
TravelMate	Forward Wi-Fi hotspot landing page to a subsequent connected device

Ethernet

WAN	1 x WAN port 10/100 Mbps, compliance IEEE 802.3, IEEE 802.3u, 802.3az standards, supports auto MDI/MDIX
LAN	1 x LAN port, 10/100 Mbps, compliance with IEEE 802.3, IEEE 802.3u standards, supports auto MDI/MDIX

Network

Routing	Static routing, Dynamic routing (BGP, OSPF v2, RIP v1/v2, EIGRP, NHRP), Policy based routing
Network protocols	TCP, UDP, IPv4, IPv6, ICMP, NTP, DNS, HTTP, HTTPS, SFTP, FTP, SMTP, SSL/TLS, ARP, VRRP, PPP, PPPoE, UPNP, SSH, DHCP, Telnet, SMPP, SNMP, MQTT, Wake On Lan (WOL), VXLAN
VoIP passthrough support	H.323 and SIP-alg protocol NAT helpers, allowing proper routing of VoIP packets
Connection monitoring	Ping Reboot, Wget Reboot, Periodic Reboot, LCP and ICMP for link inspection
Firewall	Port forward, traffic rules, custom rules, TTL target customisation
Firewall status page	View all your Firewall statistics, rules, and rule counters
Port management	View device ports, enable and disable each of them, turn auto-configuration on or off, change their transmission speed, and so on
Network topology	Visual representation of your network, showing which devices are connected to which other devices
Hotspot	Captive portal (hotspot), internal/external Radius server, Radius MAC authentication, SMS authorisation, SSO authentication, internal/external landing page, walled garden, user scripts, URL parameters, user groups, individual user or group limitations, user management, 9 default customisable themes and optionality to upload and download customised hotspot themes
DHCP	Static and dynamic IP allocation, DHCP relay, DHCP server configuration, status, static leases: MAC with wildcards
QoS / Smart Queue Management (SQM)	Traffic priority queuing by source/destination, service, protocol or port, WMM, 802.11e
DDNS	Supported >77 service providers, others can be configured manually
DNS over HTTPS	DNS over HTTPS proxy enables secure DNS resolution by routing DNS queries over HTTPS
Network backup	Wi-Fi WAN, Mobile, VRRP, Wired options, each of which can be used as an automatic Failover
Load balancing	Balance Internet traffic over multiple WAN connections
SSHFS	Possibility to mount remote file system via SSH protocol
Traffic Management	Real-time monitoring, wireless signal charts, traffic usage history

Security

Authentication	Pre-shared key, digital certificates, X.509 certificates, TACACS+, Internal & External RADIUS users authentication, IP & login attempts block, time-based login blocking, built-in random password generator
Firewall	Preconfigured firewall rules can be enabled via WebUI, unlimited firewall configuration via CLI, DMZ, NAT, NAT-T, NAT64
Attack prevention	DDOS prevention (SYN flood protection, SSH attack prevention, HTTP/HTTPS attack prevention), port scan prevention (SYN-FIN, SYN-RST, X-mas, NULL flags, FIN scan attacks)
VLAN	Port and tag-based VLAN separation
Mobile quota control	Mobile data limit, customizable period, start time, warning limit, phone number
WEB filter	Block list for blocking out unwanted websites, allow list for specifying allowed sites only
Access control	Flexible access control of SSH, Web interface, CLI and Telnet
Certificate Manager	Certificate creation tool allows to create CA, server, client, let's encrypt, SCEP certificates
802.1x	Port-based network access control server

VPN

OpenVPN	Multiple clients and a server can run simultaneously, 27 encryption methods
OpenVPN Encryption	DES-CBC 64, RC2-CBC 128, DES-EDE-CBC 128, DES-EDE3-CBC 192, DESX-CBC 192, BF-CBC 128, RC2-40-CBC 40, CAST5-CBC 128, RC2-64-CBC 64, AES-128-CBC 128, AES-128-CFB 128, AES-128-CFB1 128, AES-128-CFB8 128, AES-128-OFB 128, AES-128-GCM 128, AES-192-CFB 192, AES-192-CFB1 192, AES-192-CFB8 192, AES-192-OFB 192, AES-192-CBC 192, AES-192-GCM 192, AES-256-GCM 256, AES-256-CFB 256, AES-256-CFB1 256, AES-256-CFB8 256, AES-256-OFB 256, AES-256-CBC 256
IPsec	XFRM, IKEv1, IKEv2, with 14 encryption methods for IPsec (3DES, DES, AES128, AES192, AES256, AES128GCM8, AES192GCM8, AES256GCM8, AES128GCM12, AES192GCM12, AES256GCM12, AES128GCM16, AES192GCM16, AES256GCM16)
GRE	GRE tunnel, GRE tunnel over IPsec support
PPTP, L2TP	Client/Server instances can run simultaneously, L2TPv3, L2TP over IPsec support
Stunnel	Proxy designed to add TLS encryption functionality to existing clients and servers without any changes in the program's code
DMVPN	Method of building scalable IPsec VPNs, Phase 2 and Phase 3 and Dual Hub support
SSTP	SSTP client instance support
ZeroTier	ZeroTier VPN client support
WireGuard	WireGuard VPN client and server support
Tinc	Tinc offers encryption, authentication and compression in it's tunnels. Client and server support.

OPC UA

Supported modes	Client, Server
Supported connection types	TCP

MODBUS

Supported modes	Server, Client
Supported connection types	TCP
Custom registers	MODBUS TCP custom register block requests, which read/write to a file inside the router, and can be used to extend MODBUS TCP Client functionality
Supported data formats	8-bit: INT, UINT; 16-bit: INT, UINT (MSB or LSB first); 32-bit: float, INT, UINT (ABCD (big-endian), DCBA (little-endian), CDAB, BADC), HEX, ASCII

Data to Server

Protocol	HTTP(S), MQTT, Azure MQTT
Data to server	Extract parameters from multiple sources and different protocols, and send them all to a single server; Custom LUA scripting, allowing scripts to utilize the router's Data to server feature

MQTT Gateway

Modbus MQTT Gateway	Allows sending commands and receiving data from MODBUS Server through MQTT broker
---------------------	---

DNP3

Supported modes	Station, Outstation
Supported connection	TCP

DLMS/COSEM

DLMS Support	DLMS - standard protocol for utility meter data exchange
Supported modes	Client
Supported connection types	TCP

API

Teltonika Networks Web API (beta) support	Expand your device's possibilities by using a set of configurable API endpoints to retrieve or change data. For more information, please refer to this documentation: https://developers.teltonika-networks.com
---	---

Monitoring & Management

WEB UI	HTTP/HTTPS, status, configuration, FW update, CLI, troubleshoot, multiple event log servers, firmware update availability notifications, event log, system log, kernel log, Internet status
FOTA	Firmware update from server, automatic notification
SSH	SSH (v1, v2)
SMS	SMS status, SMS configuration
Call	Reboot, Status, Mobile data on/off, Output on/off, answer/hang-up with a timer, Wi-Fi on/off
TR-069	OpenACS, EasyCwmp, ACSLite, tGem, LibreACS, GenieACS, FreeACS, LibCWMP, Friendly tech, AVSystem
MQTT	MQTT Broker, MQTT publisher
SNMP	SNMP (v1, v2, v3), SNMP Trap, Brute force protection
JSON-RPC	Management API over HTTP/HTTPS
RMS	Teltonika Remote Management System (RMS)

IoT Platforms

ThingWorx	Allows monitoring of: WAN Type, WAN IP, Mobile Operator Name, Mobile Signal Strength, Mobile Network Type
Cumulocity - Cloud of Things	Allows monitoring of: Device Model, Revision and Serial Number, WAN Type and IP, Mobile Cell ID, ICCID, IMEI, Connection Type, Operator, Signal Strength. Has reboot and firmware upgrade actions
Azure IoT Hub	Can be configured with Data to Server to send all the available parameters to the cloud. Has Direct method support which allows to execute RutOS API calls on the IoT Hub. Also has Plug and Play integration with Device Provisioning Service that allows zero-touch device provisioning to IoT Hubs
AWS IoT Core	Utility to interact with the AWS cloud platform. Jobs Support: Call the device's API using AWS Jobs functionality

System Characteristics

CPU	Mediatek, 580 MHz, MIPS 24KEc
RAM	128 MB, DDR2
FLASH storage	16 MB, SPI Flash

Firmware/Configuration

WEB UI	Update FW from file, check FW on server, configuration profiles, configuration backup
FOTA	Update FW
RMS	Update FW/configuration for multiple devices at once
Keep settings	Update FW without losing current configuration
Factory settings reset	A full factory reset restores all system settings, including the IP address, PIN, and user data to the default manufacturer's configuration

FIRMWARE CUSTOMISATION

Operating system	RutOS (OpenWrt based Linux OS)
Supported languages	Busybox shell, Lua, C, C++
Development tools	SDK package with build environment provided
GPL customization	You can create your own custom, branded firmware and web page application by changing colours, logos, and other elements in our firmware to fit your or your clients' needs
Package Manager	The Package Manager is a service used to install additional software on the device

Input/Output

Input	1 x Digital Input, 0 - 6 V detected as logic low, 8 - 30 V detected as logic high
Output	1 x Digital Output, Open collector output, max output 30 V, 300 mA
Events	Email, RMS, SMS
I/O juggler	Allows to set certain I/O conditions to initiate event

Power

Connector	4-pin industrial DC power socket
Input voltage range	9 – 30 VDC, reverse polarity protection; surge protection >31 VDC 10us max
PoE (passive)	Passive PoE over spare pairs. Possibility to power up through LAN1 port, not compatible with IEEE802.3af, 802.3at and 802.3bt standards, Mode B, 9 - 30 VDC
Power consumption	< 6.5 W Max

Physical Interfaces

Ethernet	2 x RJ45 ports, 10/100 Mbps
I/O's	1 x Digital Input, 1 x Digital Output on 4-pin power connector
Status LEDs	3 x Connection type status LEDs, 5 x Connection strength LEDs, 2 x LAN status LEDs, 1 x Power LED
SIM	1 x SIM slot (Mini SIM – 2FF), 1.8 V/3 V, external SIM holder
Power	1 x 4-pin power connector
Antennas	2 x SMA for LTE, 1 x RP-SMA for Wi-Fi antenna connectors
Reset	Reboot/User default reset/Factory reset button

Physical Specification

Casing material	Aluminium housing, plastic panels
Dimensions (W x H x D)	83 x 25 x 74 mm
Weight	125 g
Mounting options	DIN rail, wall mount, flat surface (all require additional kit)

Operating Environment

Operating temperature	-40 °C to 75 °C
Operating humidity	10% to 90% non-condensing
Ingress Protection Rating	IP30

Regulatory & Type Approvals

Regulatory	CE, UKCA, ANRT, Kenya, ICASA, FCC, IC, PTCRB, NOM, RCM, KC, Giteki, IMDA, E-mark, CB, UL/CSA Safety, RoHS, REACH, R118, ETA-WPC, MTCCTE
Operator	AT&T, Verizon, T-Mobile, Uscellular

EMC Emissions & Immunity

Standards	EN 55032:2015 + A11:2020 EN 55035:2017 + A11:2020 EN IEC 61000-3-2:2019 EN 61000-3-3:2013 + A1:2019 EN 301 489-1 V2.2.3 EN 301 489-17 V3.2.4 Final Draft EN 301 489-52 V1.2.0
ESD	EN 61000-4-2:2009
Radiated Immunity	EN IEC 61000-4-3:2020
EFT	EN 61000-4-4:2012
Surge Immunity (AC Mains Power Port)	EN 61000-4-5:2014 + A1:2017
CS	EN 61000-4-6:2014
DIP	EN 61000-4-11:2020

RF

Standards	EN 300 328 V2.2.2 EN 301 511 V12.5.1 EN 301 908-1 V15.2.1 EN 301 908-2 V13.1.1 EN 301 908-13 V13.2.1
-----------	--

Safety

Standards	CE: EN IEC 62368-1:2020 + A11:2020, EN IEC 62311:2020, EN 50665:2017 RCM: AS/NZS 62368.1:2022 CB: IEC 62368-1:2018 UL/CSA Safety: UL 62368-1, Ed. 3 dated December 13, 20, CAN/CSA C22.2 No. 62368-1:19
-----------	--

Hardware

FRONT VIEW

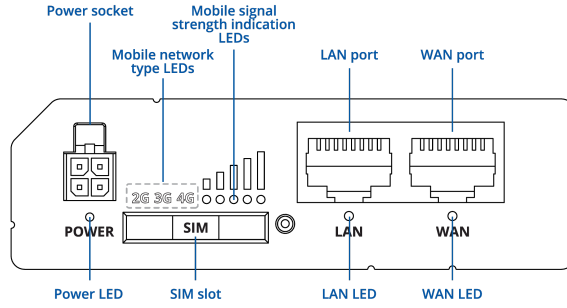

BACK VIEW

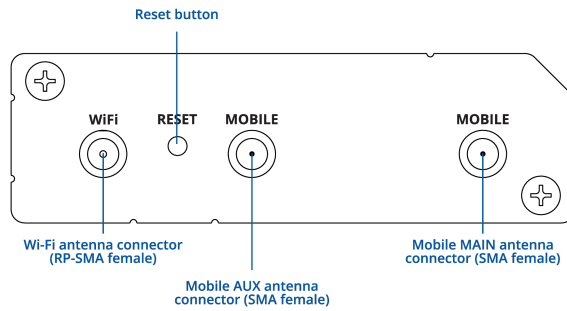

POWER SOCKET PINOUT

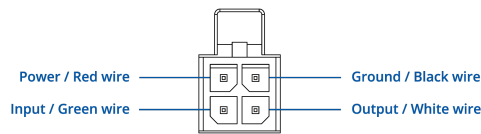

Ordering

Standard package*



RUT241



QUICK START GUIDE



9 W PSU



2 X MOBILE SMA ANTENNAS



1 X WI-FI SMA ANTENNA

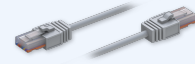

ETHERNET CABLE 1.5 M



SIM ADAPTER KIT

*Standard package contents may differ based on standard order codes.

For more information on all available packaging options – please [contact us](#) directly.

Classification codes

HS Code: 851762

HTS: 8517.62.00

For more information on all available packaging options – please [contact us](#) directly.

Available versions

Hardware version	Supported frequencies	Standard order code / Package Contains
RUT241 20**** Europe ¹ , The Middle East ¹ , Africa, Thailand eSIM	4G (LTE-FDD): B1, B3, B7, B8, B20, B28A 3G: B1, B8 2G: B3, B8	RUT241200000 / Standard package with EU PSU RUT241202030 / Mass packing code RUT241201000 / Standard package with UK PSU
RUT241 21**** Europe ¹ eSIM	4G (LTE-FDD): B1, B3, B5, B7, B8, B20 4G (LTE-TDD): B40 3G: B1, B5, B8 2G: B3, B8	RUT241210000 / Standard package with EU PSU RUT241211000 / Standard package with UK PSU RUT24122D020 / Standard package with KR PSU RUT241213000 / Standard package with Universal PSU RUT241212030 / Mass packing code
RUT241 23**** Global ¹ eSIM	4G (LTE-FDD): B1, B2, B3, B4, B5, B7, B8, B12, B13, B18, B19, B20, B25, B26, B28 4G (LTE-TDD): B38, B39, B40, B41 3G: B1, B2, B4, B5, B6, B8, B19 2G: B2, B3, B5, B8	RUT241230000 / Standard package with EU PSU RUT241238000 / Standard package with US PSU RUT241235000 / Standard package with AU PSU RUT2412370H0 / Standard package with JP PSU RUT241233000 / Standard package with Universal PSU RUT241232030 / Mass packing code
RUT241 26**** Australia, New Zealand, Taiwan eSIM	4G (LTE-FDD): B1, B3, B5, B7, B8, B28 4G (LTE-TDD): B40 3G: B1, B5, B8 2G: B3, B5, B8	RUT241262030 / Mass packing code RUT241265000 / Standard package with AU PSU
RUT241 27**** Latin America eSIM	4G (LTE-FDD): B1, B2, B3, B4, B5, B7, B8, B28 4G (LTE-TDD): B40 3G: B1, B2, B4, B5, B8 2G: B2, B3, B5, B8	RUT241272030 / Mass packing code RUT241275000 / Standard package with AU PSU
RUT241 28**** Japan eSIM	4G (LTE-FDD): B1, B3, B8, B18, B19, B26 4G (LTE-TDD): B41 3G: B1, B6, B8, B19	RUT241287000 / Standard package with JP PSU RUT241282030 / Mass packing code
RUT241 29**** North America	4G (LTE-FDD): B2, B4, B12, B13, B14, B66, B71	RUT241298000 / Standard package with US PSU

eSIM	3G: B2, B4, B5	RUT241292030 / Mass packing code RUT241294000 / Standard package with power cable (4-way screw terminal)
RUT241 *0**** Europe ¹ , The Middle East ¹ , Africa, Thailand	4G (LTE-FDD): B1, B3, B7, B8, B20, B28A 3G: B1, B8 2G: B3, B8	RUT241000000 / Standard package with EU PSU RUT241001000 / Standard package with UK PSU RUT241004000 / Standard package with power cable (4-way screw terminal) RUT241002030 / Mass packing code
RUT241 *1**** Europe ¹ , The Middle East ¹ , Africa	4G (LTE-FDD): B1, B3, B5, B7, B8, B20 4G (LTE-TDD): B40 3G: B1, B5, B8 2G: B3, B8	RUT241010000 / Standard package with EU PSU RUT241011000 / Standard package with UK PSU RUT241012030 / Mass packing code
RUT241 *2**** Korea	4G (LTE-FDD): B1, B3, B5, B7, B8, B20 4G (LTE-TDD): B38, B40, B41 3G: B1, B5, B8 2G: B3, B8	RUT241022020 / Standard package without PSU RUT24102D020 / Standard package with KR PSU
RUT241 *3**** Global ¹	4G (LTE-FDD): B1, B2, B3, B4, B5, B7, B8, B12, B13, B18, B19, B20, B25, B26, B28 4G (LTE-TDD): B38, B39, B40, B41 3G: B1, B2, B4, B5, B6, B8, B19 2G: B2, B3, B5, B8	RUT2410300G0 / Standard package with EU PSU RUT241034000 / Standard package with power cable (4-way screw terminal) RUT241033000 / Standard package with Universal PSU RUT2410370H0 / Standard package with JP PSU RUT241038000 / Standard package with US PSU RUT241032030 / Mass packing code
RUT241 *6**** Australia, New Zealand, Taiwan	4G (LTE-FDD): B1, B3, B5, B7, B8, B28 4G (LTE-TDD): B40 3G: B1, B5, B8 2G: B3, B5, B8	RUT241065000 / Standard package with AU PSU
RUT241 *7**** Latin America	4G (LTE-FDD): B1, B2, B3, B4, B5, B7, B8, B28 4G (LTE-TDD): B40 3G: B1, B2, B4, B5, B8 2G: B2, B3, B5, B8	RUT241070000 / Standard package with EU PSU
RUT241 *8**** Japan	4G (LTE-FDD): B1, B3, B8, B18, B19, B26 4G (LTE-TDD): B41 3G: B1, B6, B8, B19	RUT241087000 / Standard package with JP PSU RUT241082030 / Mass packing code
RUT241 *9**** North America ²	4G (LTE-FDD): B2, B4, B5, B12, B13, B14, B66, B71 3G: B2, B4, B5	RUT241098000 / Standard package with US PSU

RUT241093000 / Standard package with
Universal PSU
RUT241092030 / Mass packing code
RUT241094000 / Standard package with
power cable (4-way screw terminal)

The price and lead-times for region (operator) specific versions may vary. For more information please [contact us](#).

- 1 - Regional availability - excluding Russia, Belarus & Iran
- 2 - For more detailed information about certified carriers, visit our [Wiki](#) page

RUT241 spatial measurements

Available versions

Device housing (W x H x D)*	83 x 25 x 74 mm
-----------------------------	-----------------

Box (W x H x D):	173 x 71 x 148 mm
------------------	-------------------

*Housing measurements are presented without antenna connectors and screws; for measurements of other device elements look to the sections below

MOUNTING SPACE REQUIREMENTS

The figure below depicts an approximation of the device's dimensions when cables and antennas are attached:

