

# HEF4541B

## Programmable timer

Rev. 4 — 25 June 2012

Product data sheet

## 1. General description

The HEF4541B is a programmable timer which consists of a 16-stage binary counter, an integrated oscillator to be used with external timing components, an automatic power-on reset and output control logic. The frequency of the oscillator is determined by the external components  $R_{TC}$  and  $C_{TC}$  within the frequency range 1 Hz to 100 kHz. This oscillator may be replaced by an external clock signal at input RS, the timer advances on the positive-going transition of RS. A LOW on the auto reset input (AR) and a LOW on the master reset input (MR) enables the internal power-on reset. A HIGH level at input MR resets the counter independent on all other inputs. Resetting disables the oscillator to provide no active power dissipation.

A HIGH at input AR turns off the power-on reset to provide a low quiescent power dissipation of the timer. The 16-stage counter divides the oscillator frequency by  $2^8$ ,  $2^{10}$ ,  $2^{13}$  or  $2^{16}$  depending on the state of the address inputs (A0, A1). The divided oscillator frequency is available at output O. The phase input (PH) features a complementary output signal. When the mode select input (MODE) is LOW the timer is a single transition timer and when HIGH the timer is a  $2^n$  frequency divider.

It operates over a recommended  $V_{DD}$  power supply range of 3 V to 15 V referenced to  $V_{SS}$  (usually ground). Unused inputs must be connected to  $V_{DD}$ ,  $V_{SS}$ , or another input.

## 2. Features and benefits

- Fully static operation
- 5 V, 10 V, and 15 V parametric ratings
- Standardized symmetrical output characteristics
- Operates across the automotive temperature range  $-40\text{ }^{\circ}\text{C}$  to  $+85\text{ }^{\circ}\text{C}$
- Complies with JEDEC standard JESD 13-B

## 3. Ordering information

**Table 1. Ordering information**

All types operate from  $-40\text{ }^{\circ}\text{C}$  to  $+85\text{ }^{\circ}\text{C}$ .

Type number	Package		Version
	Name	Description	
HEF4541BP	DIP14	plastic dual in-line package; 14 leads (300 mil)	SOT27-1
HEF4541BT	SO14	plastic small outline package; 14 leads; body width 3.9 mm	SOT108-1



4. Functional diagram

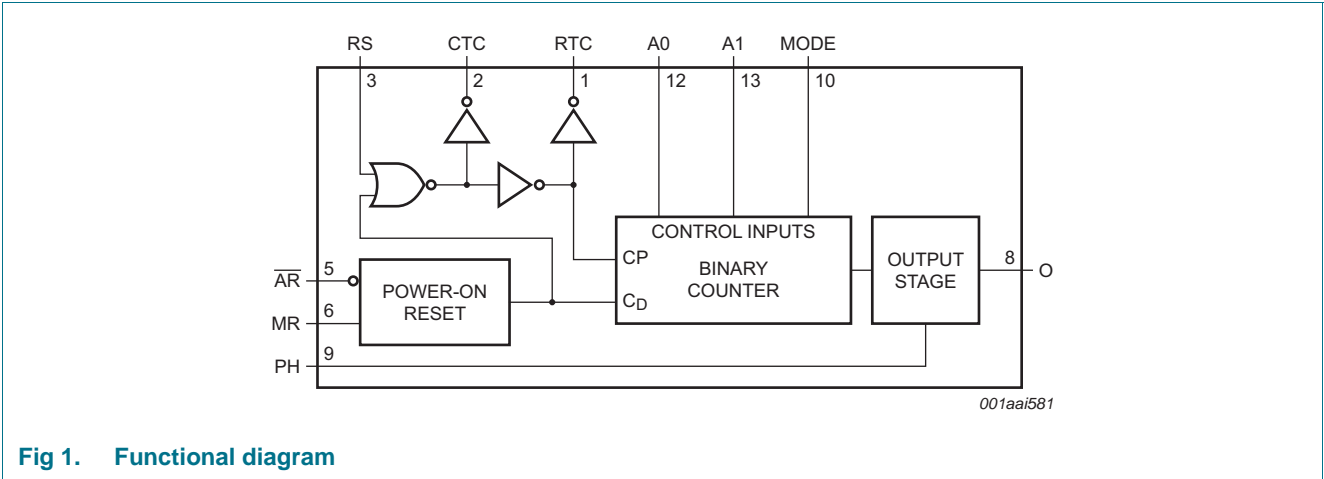

Fig 1. Functional diagram

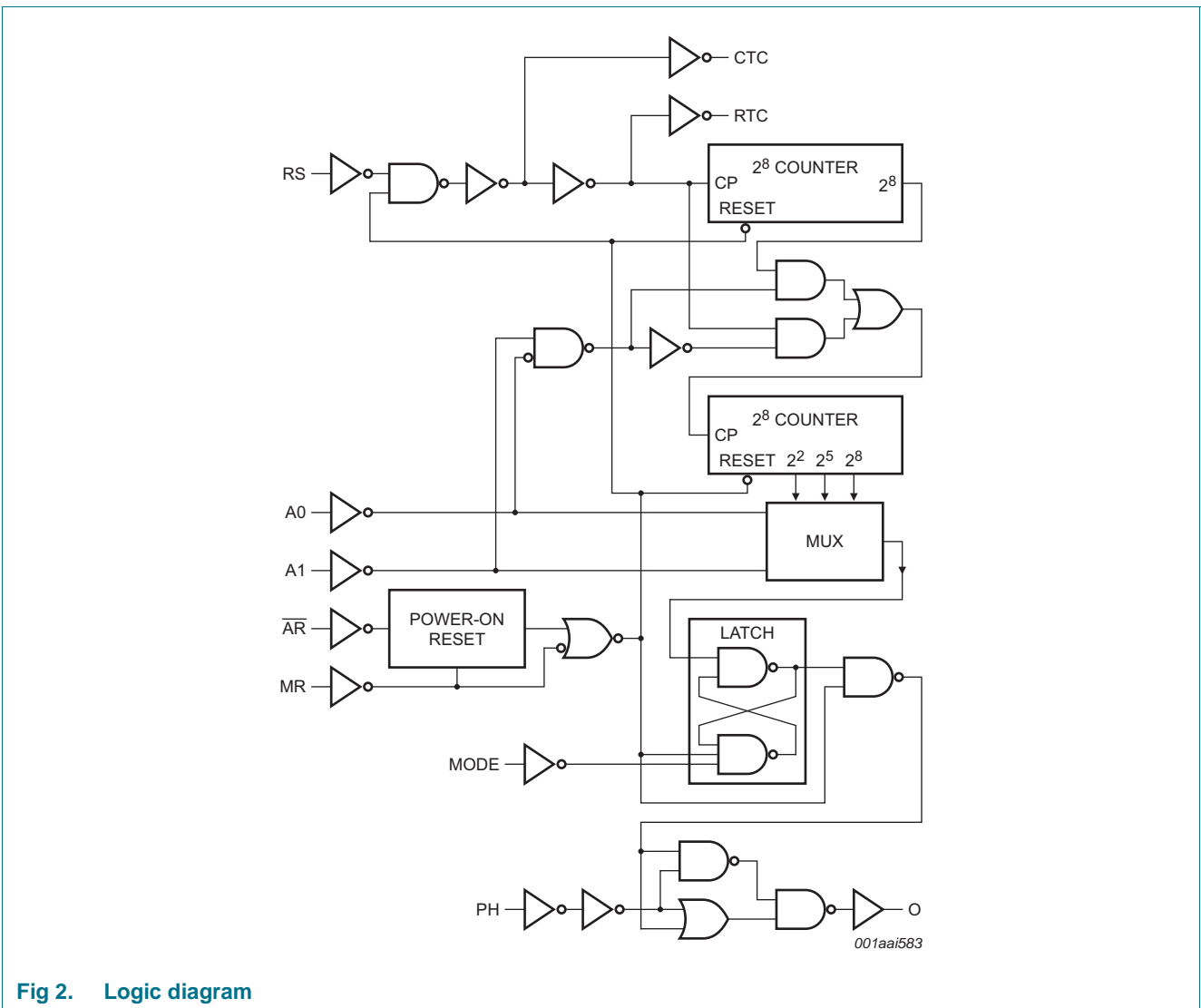
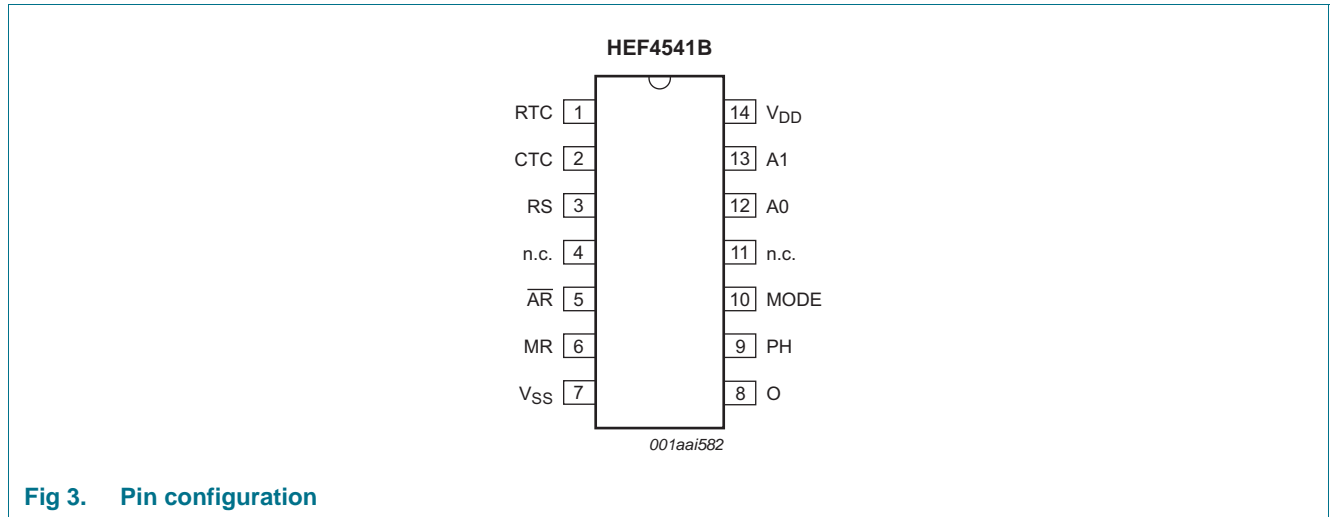

Fig 2. Logic diagram

## 5. Pinning information

### 5.1 Pinning



### 5.2 Pin description

**Table 2. Pin description**

Symbol	Pin	Description
RTC	1	external resistor connection
CTC	2	external capacitor connection
RS	3	external resistor connection (RS) or external clock input
nc	4, 11	not connected
$\overline{\text{AR}}$	5	auto reset input (active low)
MR	6	master reset input
V <sub>SS</sub>	7	ground (0 V)
O	8	timer output
PH	9	phase input
MODE	10	mode select input
A0, A1	12, 13	address inputs
V <sub>DD</sub>	14	supply voltage

## 6. Functional description

Table 3. Function table<sup>[1]</sup>

Input				MODE
AR	MR	PH	MODE	
H	L	X	X	auto reset disabled
L	L	X	X	auto reset enabled <sup>[2]</sup>
X	H	X	X	master reset active
X	L	X	H	normal operation selected division to output
X	L	X	L	single-cycle mode <sup>[3]</sup>
X	L	L	X	output initially LOW after reset
X	L	H	X	output initially HIGH, after reset

[1] H = HIGH voltage level; L = LOW voltage level; X = don't care.

[2] For correct power-on reset, the supply voltage should be above 8.5 V. For  $V_{DD} < 8.5$  V, disable the autoreset and connect  $\overline{AR}$  to  $V_{DD}$ .

[3] The timer is initialized on a reset pulse and the output changes state after  $2^{n-1}$  counts and remains in that state (latched). Reset of this latch is obtained by master reset or by a LOW to HIGH transition on the MODE input.

Table 4. Frequency selection table

A0	A1	Number of counter stages n	$\frac{f_{osc}}{f_o} = 2^n$
L	L	13	8192
L	H	10	1024
H	L	8	256
H	H	16	65536

## 7. Limiting values

Table 5. Limiting values

In accordance with the Absolute Maximum Rating System (IEC 60134).

Symbol	Parameter	Conditions	Min	Max	Unit
$V_{DD}$	supply voltage		-0.5	+18	V
$I_{IK}$	input clamping current	$V_I < -0.5$ V or $V_I > V_{DD} + 0.5$ V	-	$\pm 10$	mA
$V_I$	input voltage		-0.5	$V_{DD} + 0.5$	V
$I_{OK}$	output clamping current	$V_O < -0.5$ V or $V_O > V_{DD} + 0.5$ V	-	$\pm 10$	mA
$I_{I/O}$	input/output current	O output	-	$\pm 10$	mA
$T_{stg}$	storage temperature		-65	+150	°C
$T_{amb}$	ambient temperature		-40	+85	°C
$P_{tot}$	total power dissipation	$T_{amb} = -40$ °C to +85 °C			
		DIP14 package	<sup>[1]</sup> -	750	mW
		SO14 package	<sup>[2]</sup> -	500	mW
P	power dissipation		-	100	mW

[1] For DIP14 package:  $P_{tot}$  derates linearly with 12 mW/K above 70 °C.

[2] For SO14 package:  $P_{tot}$  derates linearly with 8 mW/K above 70 °C.

## 8. Recommended operating conditions

Table 6. Recommended operating conditions

Symbol	Parameter	Conditions	Min	Max	Unit
$V_{DD}$	supply voltage		3	15	V
$V_I$	input voltage		0	$V_{DD}$	V
$T_{amb}$	ambient temperature	in free air	-40	+85	°C
$\Delta t/\Delta V$	input transition rise and fall rate	$V_{DD} = 5\text{ V}$	-	3.75	$\mu\text{s/V}$
		$V_{DD} = 10\text{ V}$	-	0.5	$\mu\text{s/V}$
		$V_{DD} = 15\text{ V}$	-	0.08	$\mu\text{s/V}$

## 9. Static characteristics

Table 7. Static characteristics

$V_{SS} = 0\text{ V}$ ;  $V_I = V_{SS}$  or  $V_{DD}$ ; unless otherwise specified.

Symbol	Parameter	Conditions	$V_{DD}$	$T_{amb} = -40\text{ °C}$		$T_{amb} = 25\text{ °C}$		$T_{amb} = 85\text{ °C}$		Unit
				Min	Max	Min	Max	Min	Max	
$V_{IH}$	HIGH-level input voltage	$ I_O  < 1\ \mu\text{A}$	5 V	3.5	-	3.5	-	3.5	-	V
			10 V	7.0	-	7.0	-	7.0	-	V
			15 V	11.0	-	11.0	-	11.0	-	V
$V_{IL}$	LOW-level input voltage	$ I_O  < 1\ \mu\text{A}$	5 V	-	1.5	-	1.5	-	1.5	V
			10 V	-	3.0	-	3.0	-	3.0	V
			15 V	-	4.0	-	4.0	-	4.0	V
$V_{OH}$	HIGH-level output voltage	$ I_O  < 1\ \mu\text{A}$	5 V	4.95	-	4.95	-	4.95	-	V
			10 V	9.95	-	9.95	-	9.95	-	V
			15 V	14.95	-	14.95	-	14.95	-	V
$V_{OL}$	LOW-level output voltage	$ I_O  < 1\ \mu\text{A}$	5 V	-	0.05	-	0.05	-	0.05	V
			10 V	-	0.05	-	0.05	-	0.05	V
			15 V	-	0.05	-	0.05	-	0.05	V
$I_{OH}$	HIGH-level output current	CTC, RTC;								
		$V_O = 2.5\text{ V}$	5 V	-	-1.4	-	-1.2	-	-0.95	mA
		$V_O = 4.6\text{ V}$	5 V	-	-0.5	-	-0.4	-	-0.3	mA
		$V_O = 9.5\text{ V}$	10 V	-	-1.4	-	-1.2	-	-0.95	mA
		$V_O = 13.5\text{ V}$	15 V	-	-4.8	-	-4.0	-	-3.2	mA
		O;								
		$V_O = 2.5\text{ V}$	5 V	-	-1.7	-	-1.4	-	-1.1	mA
		$V_O = 4.6\text{ V}$	5 V	-	-0.64	-	-0.5	-	-0.36	mA
		$V_O = 9.5\text{ V}$	10 V	-	-1.6	-	-1.3	-	-0.9	mA
		$V_O = 13.5\text{ V}$	15 V	-	-4.2	-	-3.4	-	-2.4	mA

**Table 7. Static characteristics ...continued**  
 $V_{SS} = 0\text{ V}$ ;  $V_I = V_{SS}$  or  $V_{DD}$ ; unless otherwise specified.

Symbol	Parameter	Conditions	$V_{DD}$	$T_{amb} = -40\text{ }^\circ\text{C}$		$T_{amb} = 25\text{ }^\circ\text{C}$		$T_{amb} = 85\text{ }^\circ\text{C}$		Unit
				Min	Max	Min	Max	Min	Max	
$I_{OL}$	LOW-level output current	CTC, RTC; $V_O = 0.4\text{ V}$	5 V	0.33	-	0.27	-	0.20	-	mA
			10 V	1.0	-	0.85	-	0.68	-	mA
			15 V	3.2	-	2.7	-	2.3	-	mA
		O; $V_O = 0.4\text{ V}$	5 V	0.64	-	0.5	-	0.36	-	mA
			10 V	1.6	-	1.3	-	0.9	-	mA
			15 V	4.2	-	3.2	-	2.4	-	mA
$I_I$	input leakage current		15 V	-	$\pm 0.1$	-	$\pm 0.1$	-	$\pm 1.0$	$\mu\text{A}$
$I_{DD}$	supply current	$I_O = 0\text{ A}$	5 V	-	5	-	5	-	150	$\mu\text{A}$
			10 V	-	10	-	10	-	300	$\mu\text{A}$
			15 V	-	20	-	20	-	600	$\mu\text{A}$
$C_I$	input capacitance		-	-	-	-	7.5	-	-	pF

**Table 8. Reset characteristics**  
 $V_{SS} = 0\text{ V}$ ;  $V_I = V_{SS}$  or  $V_{DD}$ ; see [Table 12](#) for test conditions; unless otherwise specified.

Symbol	Parameter	Conditions	$V_{DD}$	$T_{amb} = -40\text{ }^\circ\text{C}$		$T_{amb} = +25\text{ }^\circ\text{C}$			$T_{amb} = +85\text{ }^\circ\text{C}$		Unit
				Min	Max	Min	Typ	Max	Min	Max	
$I_{DD}$	supply current	supply current for power-on reset enable; $\overline{AR} = \overline{MR} = 0\text{ V}$ ; Other inputs at 0 V or $V_{DD}$	5 V	-	80	-	20	80	-	230	$\mu\text{A}$
			10 V	-	750	-	250	600	-	700	$\mu\text{A}$
			15 V	-	1.6	-	0.5	1.3	-	1.5	mA
$V_{DD}$	supply voltage	supply voltage for automatic reset initialization; $\overline{AR} = \overline{MR} = 0\text{ V}$ ; Other inputs at 0 V or $V_{DD}$	-	-	-	8.5	5	-	-	-	V

## 10. Dynamic characteristics

**Table 9. Dynamic characteristics**

$V_{SS} = 0\text{ V}$ ;  $T_{amb} = 25\text{ °C}$  unless otherwise specified. For test circuit, see [Figure 5](#).

Symbol	Parameter	Conditions	$V_{DD}$	Extrapolation formula	Min	Typ <sup>[1]</sup>	Max	Unit
$t_{pd}$	propagation delay	RS to O; 2 <sup>8</sup> selected; see <a href="#">Figure 4</a>	5 V <sup>[2]</sup>	$348\text{ ns} + (0.55\text{ ns/pF})C_L$	-	375	750	ns
			10 V	$139\text{ ns} + (0.23\text{ ns/pF})C_L$	-	150	300	ns
			15 V	$102\text{ ns} + (0.16\text{ ns/pF})C_L$	-	110	220	ns
		RS to O; 2 <sup>10</sup> selected; see <a href="#">Figure 4</a>	5 V	$398\text{ ns} + (0.55\text{ ns/pF})C_L$	-	425	850	ns
			10 V	$154\text{ ns} + (0.23\text{ ns/pF})C_L$	-	165	330	ns
			15 V	$112\text{ ns} + (0.16\text{ ns/pF})C_L$	-	120	240	ns
		RS to O; 2 <sup>13</sup> selected; see <a href="#">Figure 4</a>	5 V	$483\text{ ns} + (0.55\text{ ns/pF})C_L$	-	510	1020	ns
			10 V	$179\text{ ns} + (0.23\text{ ns/pF})C_L$	-	190	380	ns
			15 V	$127\text{ ns} + (0.16\text{ ns/pF})C_L$	-	135	270	ns
		RS to O; 2 <sup>16</sup> selected; see <a href="#">Figure 4</a>	5 V	$548\text{ ns} + (0.55\text{ ns/pF})C_L$	-	575	1150	ns
			10 V	$199\text{ ns} + (0.23\text{ ns/pF})C_L$	-	210	420	ns
			15 V	$142\text{ ns} + (0.16\text{ ns/pF})C_L$	-	150	300	ns
$t_W$	pulse width	RS LOW; MR HIGH; see <a href="#">Figure 4</a>	5 V <sup>[3]</sup>		60	30	-	ns
			10 V		30	15	-	ns
			15 V		24	12	-	ns
$f_{clk(max)}$	maximum clock frequency	RS; see <a href="#">Figure 4</a>	5 V		8	16	-	MHz
			10 V		15	30	-	MHz
			15 V		18	36	-	MHz
$f_{osc}$	oscillator frequency	$R_t = 5\text{ k}\Omega$ ; $C_t = 1\text{ nF}$ ; $R_S = 10\text{ k}\Omega$ ; see <a href="#">Figure 6</a>	5 V		-	90	-	kHz
			10 V		-	90	-	kHz
			15 V		-	90	-	kHz
		$R_t = 56\text{ k}\Omega$ ; $C_t = 1\text{ nF}$ ; $R_S = 120\text{ k}\Omega$ ; see <a href="#">Figure 6</a>	5 V		-	8	-	kHz
			10 V		-	8	-	kHz
			15 V		-	8	-	kHz

[1] The typical values of the propagation delay and transition times are calculated from the extrapolation formulas shown ( $C_L$  in pF).

[2]  $t_{pd}$  is the same as  $t_{PHL}$  and  $t_{PLH}$ .

[3]  $t_W$  is the same as  $t_{WL(min)}$  and  $t_{WH(min)}$ .

**Table 10. Dynamic power dissipation**

$P_D$  can be calculated from the formulas shown.  $V_{SS} = 0\text{ V}$ ;  $t_r = t_f \leq 20\text{ ns}$ ;  $T_{amb} = 25\text{ }^\circ\text{C}$ .

Symbol	Parameter	$V_{DD}$	Typical formula
<b>Per package</b>			
$P_D$	dynamic power dissipation	5 V	$P_D = 1300 \times f_i + (f_o \times C_L \times V_{DD}^2)\ \mu\text{W}$
		10 V	$P_D = 5300 \times f_i + (f_o \times C_L \times V_{DD}^2)\ \mu\text{W}$
		15 V	$P_D = 12000 \times f_i + (f_o \times C_L \times V_{DD}^2)\ \mu\text{W}$
<b>Using the on-chip oscillator</b>			
$P_{D(Tot)}$	Total dynamic power dissipation	5 V	$P_D = 1300 \times f_{osc} + f_o C_L V_{DD}^2 + 2C_{TC} V_{DD}^2 f_{osc} + 10V_{DD}\ \mu\text{W}$
		10 V	$P_D = 5300 \times f_{osc} + f_o C_L V_{DD}^2 + 2C_{TC} V_{DD}^2 f_{osc} + 100V_{DD}\ \mu\text{W}$
		15 V	$P_D = 12000 \times f_{osc} + f_o C_L V_{DD}^2 + 2C_{TC} V_{DD}^2 f_{osc} + 400V_{DD}\ \mu\text{W}$

[1]  $f_i$  = input frequency in MHz;  $f_o$  = output frequency in MHz;  $C_L$  = output load capacitance in pF;  $V_{DD}$  = supply voltage in V;  $f_{osc}$  = oscillator frequency in MHz;  $C_{TC}$  = timing capacitance in pF.

## 11. Waveforms

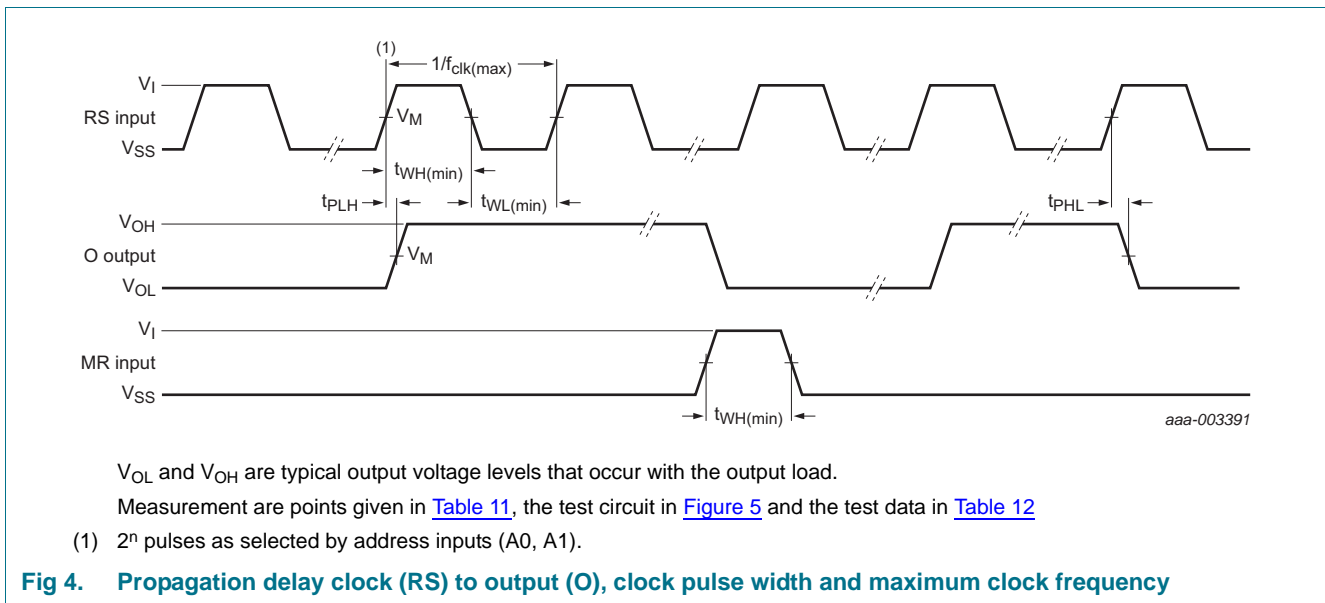

**Table 11. Measurement points**

Supply voltage	Input	Output
$V_{DD}$	$V_M$	$V_M$
5 V to 15 V	$0.5V_{DD}$	$0.5V_{DD}$



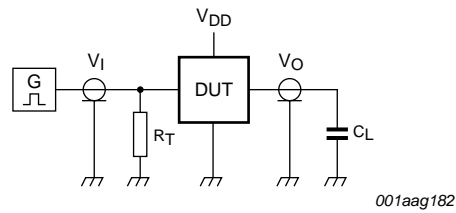

Test data is given in [Table 12](#).

Definitions for test circuit:

DUT - Device Under Test.

$R_L$  = Load resistance.

$C_L$  = load capacitance.

$R_T$  = Termination resistance should be equal to output impedance of  $Z_o$  of the pulse generator.

**Fig 5. Test circuit for measuring switching times**

**Table 12. Test data**

Supply	Input		Load
$V_{DD}$	$V_I$	$t_r, t_f$	$C_L$
5 V to 15 V	$V_{SS}$ or $V_{DD}$	$\leq 20$ ns	50 pF

## 12. Application information

### RC oscillator timing component limitations

The oscillator frequency is mainly determined by  $R_{TC}C_{TC}$ , provided  $R_{TC} \ll R_S$  and  $R_S C_2 \ll R_{TC}C_{TC}$ . The function of  $R_S$  is to minimize the influence of the forward voltage across the input protection diodes on the frequency. The stray capacitance  $C_2$  should be kept as small as possible. In consideration of accuracy,  $C_{TC}$  must be larger than the inherent stray capacitance.  $R_{TC}$  must be larger than the LOCMOS 'ON' resistance in series with it, which typically is 500  $\Omega$  at  $V_{DD} = 5$  V, 300  $\Omega$  at  $V_{DD} = 10$  V and 200  $\Omega$  at  $V_{DD} = 15$  V.

The recommended values for these components to maintain agreement with the typical oscillation formula are:  $C_{TC} \geq 100$  pF, up to any typical value,  $10$  k $\Omega \leq R_{TC} \leq 1$  M $\Omega$ .

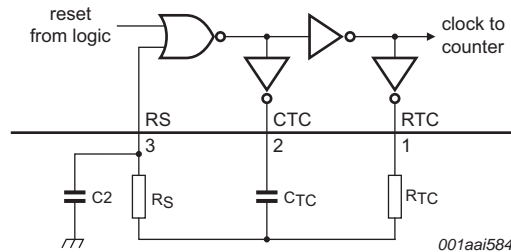

Typical formula for oscillator frequency:  $f_{osc} = \frac{1}{2.3 \times R_{TC} \times C_{TC}}$ .

Fig 6. External component connection for RC oscillator;  $R_S \approx R_{TC}$

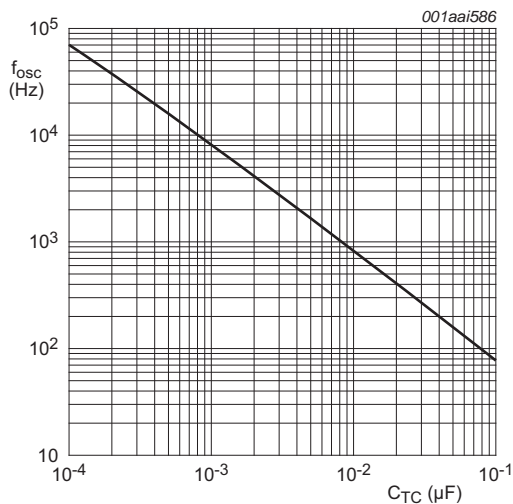

a.  $C_{TC}$  curve at  $R_{TC} = 56$  k $\Omega$ ;  $R_S = 120$  k $\Omega$ .

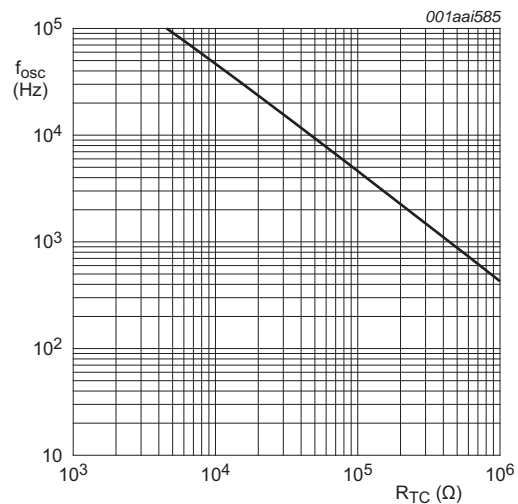

b.  $R_{TC}$  curve at  $C_{TC} = 1$  nF;  $R_S = 2 R_{TC}$ .

Fig 7. RC oscillator frequency as a function of  $R_{TC}$  and  $C_{TC}$  at  $V_{DD} = 5$  to 15 V;  $T_{amb} = 25$  °C

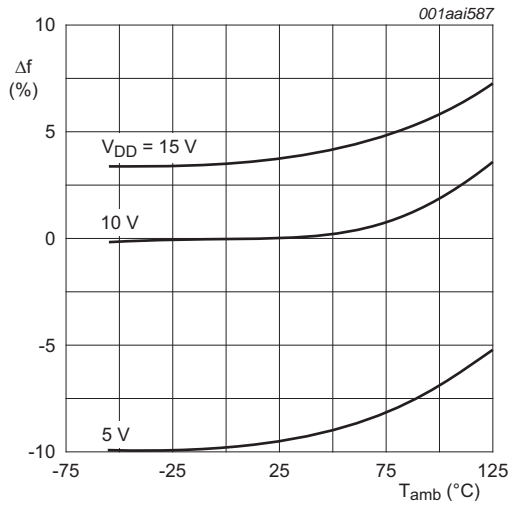

a.  $R_{TC} = 56\text{ k}\Omega$ ;  $C_{TC} = 1\text{ nF}$ ;  $R_S = 0\ \Omega$ .

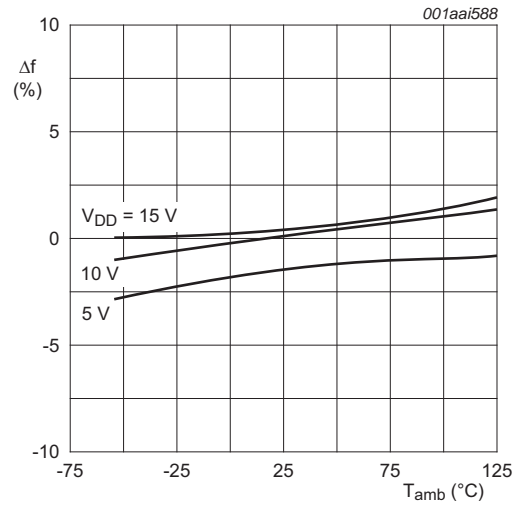

b.  $R_{TC} = 56\text{ k}\Omega$ ;  $C_{TC} = 1\text{ nF}$ ;  $R_S = 120\text{ k}\Omega$ .

Fig 8. Frequency deviation ( $\Delta f$ ) as a function of ambient temperature

13. Package outline

DIP14: plastic dual in-line package; 14 leads (300 mil)

SOT27-1

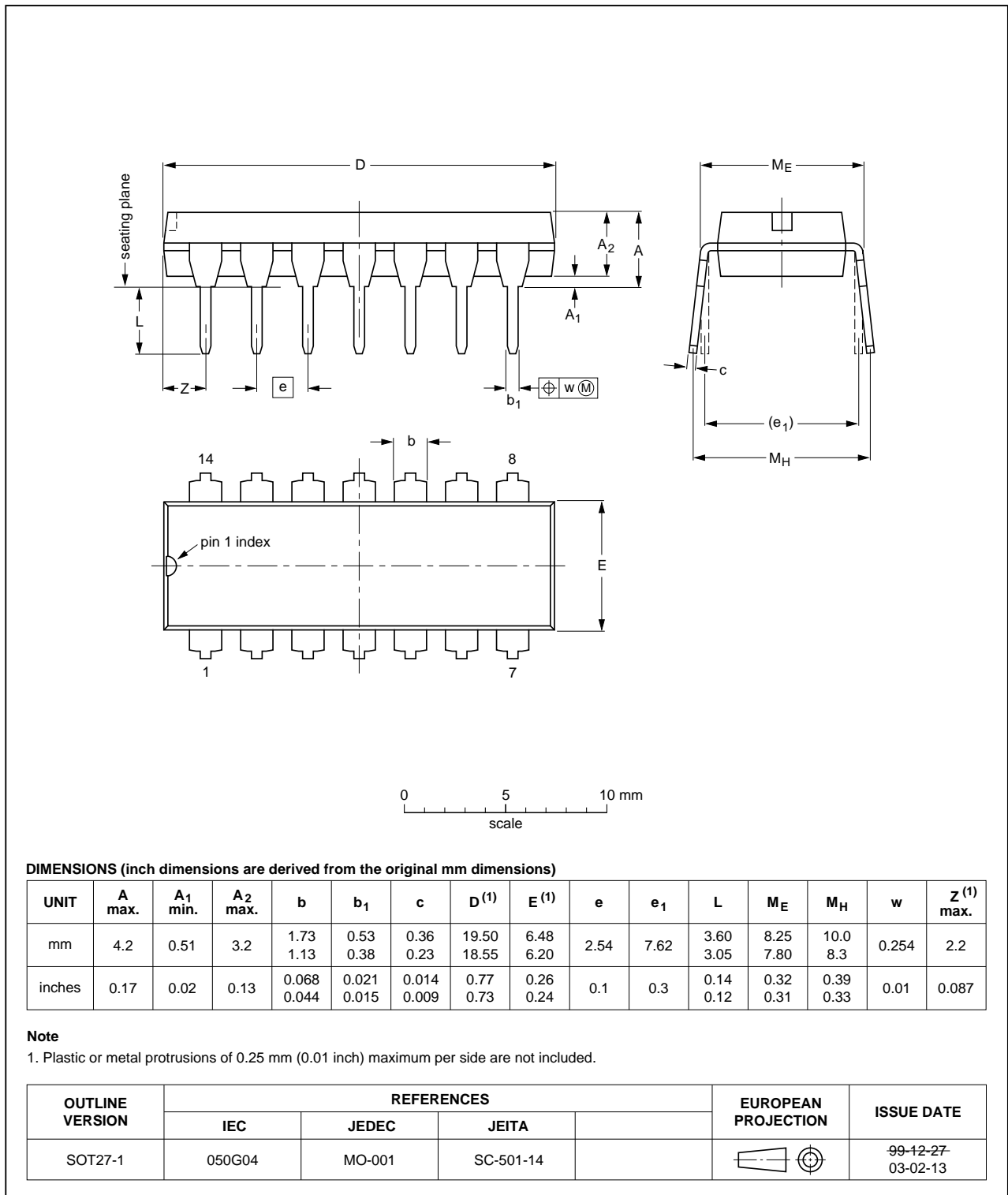

Fig 9. Package outline SOT27-1 (DIP14)

SO14: plastic small outline package; 14 leads; body width 3.9 mm

SOT108-1

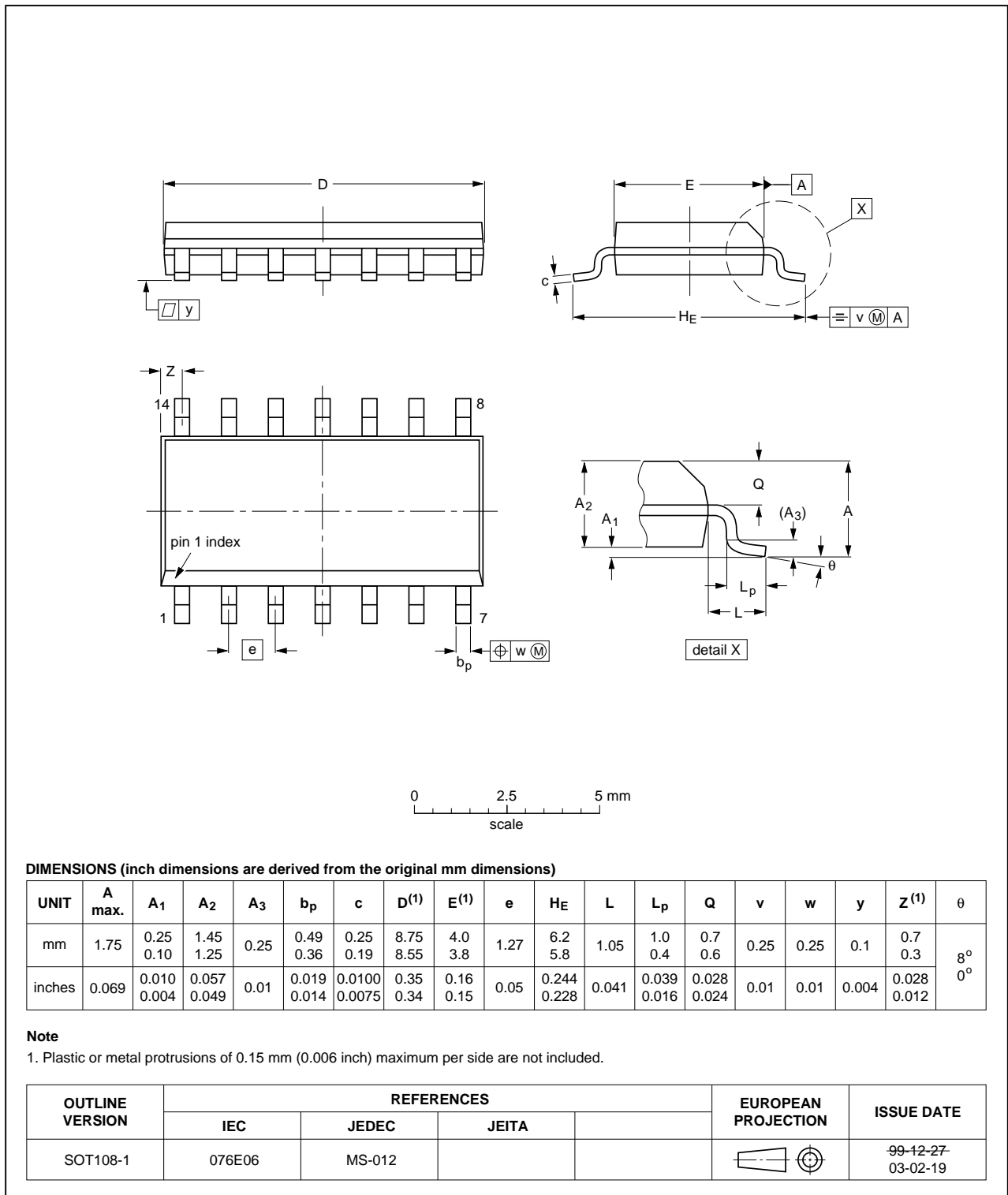

Fig 10. Package outline SOT108-1 (SO14)

## 14. Abbreviations

Table 13. Abbreviations

Acronym	Description
CMOS	Complementary Metal Oxide Semiconductor
DUT	Device Under Test
ESD	ElectroStatic Discharge
HBM	Human Body Model
MM	Machine Model
TTL	Transistor-Transistor Logic

## 15. Revision history

Table 14. Revision history

Document ID	Release date	Data sheet status	Change notice	Supersedes
HEF4541B v.4	20120625	Product data sheet	-	HEF4541B_CNV v.3
Modifications:		<ul style="list-style-type: none"><li>The format of this data sheet has been redesigned to comply with the new identity guidelines of NXP Semiconductors.</li><li>Legal texts have been adapted to the new company name where appropriate.</li><li><a href="#">Section 2 “Features and benefits”</a> added.</li></ul>		
HEF4541B_CNV v.3	19950101	Product specification	-	HEF4541B_CNV v.2
HEF4541B_CNV v.2	19950101	Product specification	-	-

## 16. Legal information

### 16.1 Data sheet status

Document status <sup>[1][2]</sup>	Product status <sup>[3]</sup>	Definition
Objective [short] data sheet	Development	This document contains data from the objective specification for product development.
Preliminary [short] data sheet	Qualification	This document contains data from the preliminary specification.
Product [short] data sheet	Production	This document contains the product specification.

[1] Please consult the most recently issued document before initiating or completing a design.

[2] The term 'short data sheet' is explained in section "Definitions".

[3] The product status of device(s) described in this document may have changed since this document was published and may differ in case of multiple devices. The latest product status information is available on the Internet at URL <http://www.nxp.com>.

### 16.2 Definitions

**Draft** — The document is a draft version only. The content is still under internal review and subject to formal approval, which may result in modifications or additions. NXP Semiconductors does not give any representations or warranties as to the accuracy or completeness of information included herein and shall have no liability for the consequences of use of such information.

**Short data sheet** — A short data sheet is an extract from a full data sheet with the same product type number(s) and title. A short data sheet is intended for quick reference only and should not be relied upon to contain detailed and full information. For detailed and full information see the relevant full data sheet, which is available on request via the local NXP Semiconductors sales office. In case of any inconsistency or conflict with the short data sheet, the full data sheet shall prevail.

**Product specification** — The information and data provided in a Product data sheet shall define the specification of the product as agreed between NXP Semiconductors and its customer, unless NXP Semiconductors and customer have explicitly agreed otherwise in writing. In no event however, shall an agreement be valid in which the NXP Semiconductors product is deemed to offer functions and qualities beyond those described in the Product data sheet.

### 16.3 Disclaimers

**Limited warranty and liability** — Information in this document is believed to be accurate and reliable. However, NXP Semiconductors does not give any representations or warranties, expressed or implied, as to the accuracy or completeness of such information and shall have no liability for the consequences of use of such information. NXP Semiconductors takes no responsibility for the content in this document if provided by an information source outside of NXP Semiconductors.

In no event shall NXP Semiconductors be liable for any indirect, incidental, punitive, special or consequential damages (including - without limitation - lost profits, lost savings, business interruption, costs related to the removal or replacement of any products or rework charges) whether or not such damages are based on tort (including negligence), warranty, breach of contract or any other legal theory.

Notwithstanding any damages that customer might incur for any reason whatsoever, NXP Semiconductors' aggregate and cumulative liability towards customer for the products described herein shall be limited in accordance with the *Terms and conditions of commercial sale* of NXP Semiconductors.

**Right to make changes** — NXP Semiconductors reserves the right to make changes to information published in this document, including without limitation specifications and product descriptions, at any time and without notice. This document supersedes and replaces all information supplied prior to the publication hereof.

**Suitability for use** — NXP Semiconductors products are not designed, authorized or warranted to be suitable for use in life support, life-critical or safety-critical systems or equipment, nor in applications where failure or malfunction of an NXP Semiconductors product can reasonably be expected to result in personal injury, death or severe property or environmental damage. NXP Semiconductors and its suppliers accept no liability for inclusion and/or use of NXP Semiconductors products in such equipment or applications and therefore such inclusion and/or use is at the customer's own risk.

**Applications** — Applications that are described herein for any of these products are for illustrative purposes only. NXP Semiconductors makes no representation or warranty that such applications will be suitable for the specified use without further testing or modification.

Customers are responsible for the design and operation of their applications and products using NXP Semiconductors products, and NXP Semiconductors accepts no liability for any assistance with applications or customer product design. It is customer's sole responsibility to determine whether the NXP Semiconductors product is suitable and fit for the customer's applications and products planned, as well as for the planned application and use of customer's third party customer(s). Customers should provide appropriate design and operating safeguards to minimize the risks associated with their applications and products.

NXP Semiconductors does not accept any liability related to any default, damage, costs or problem which is based on any weakness or default in the customer's applications or products, or the application or use by customer's third party customer(s). Customer is responsible for doing all necessary testing for the customer's applications and products using NXP Semiconductors products in order to avoid a default of the applications and the products or of the application or use by customer's third party customer(s). NXP does not accept any liability in this respect.

**Limiting values** — Stress above one or more limiting values (as defined in the Absolute Maximum Ratings System of IEC 60134) will cause permanent damage to the device. Limiting values are stress ratings only and (proper) operation of the device at these or any other conditions above those given in the Recommended operating conditions section (if present) or the Characteristics sections of this document is not warranted. Constant or repeated exposure to limiting values will permanently and irreversibly affect the quality and reliability of the device.

**Terms and conditions of commercial sale** — NXP Semiconductors products are sold subject to the general terms and conditions of commercial sale, as published at <http://www.nxp.com/profile/terms>, unless otherwise agreed in a valid written individual agreement. In case an individual agreement is concluded only the terms and conditions of the respective agreement shall apply. NXP Semiconductors hereby expressly objects to applying the customer's general terms and conditions with regard to the purchase of NXP Semiconductors products by customer.

**No offer to sell or license** — Nothing in this document may be interpreted or construed as an offer to sell products that is open for acceptance or the grant, conveyance or implication of any license under any copyrights, patents or other industrial or intellectual property rights.

**Export control** — This document as well as the item(s) described herein may be subject to export control regulations. Export might require a prior authorization from competent authorities.

**Non-automotive qualified products** — Unless this data sheet expressly states that this specific NXP Semiconductors product is automotive qualified, the product is not suitable for automotive use. It is neither qualified nor tested in accordance with automotive testing or application requirements. NXP Semiconductors accepts no liability for inclusion and/or use of non-automotive qualified products in automotive equipment or applications.

In the event that customer uses the product for design-in and use in automotive applications to automotive specifications and standards, customer (a) shall use the product without NXP Semiconductors' warranty of the product for such automotive applications, use and specifications, and (b) whenever customer uses the product for automotive applications beyond

NXP Semiconductors' specifications such use shall be solely at customer's own risk, and (c) customer fully indemnifies NXP Semiconductors for any liability, damages or failed product claims resulting from customer design and use of the product for automotive applications beyond NXP Semiconductors' standard warranty and NXP Semiconductors' product specifications.

**Translations** — A non-English (translated) version of a document is for reference only. The English version shall prevail in case of any discrepancy between the translated and English versions.

## 16.4 Trademarks

Notice: All referenced brands, product names, service names and trademarks are the property of their respective owners.

## 17. Contact information

For more information, please visit: <http://www.nxp.com>

For sales office addresses, please send an email to: [salesaddresses@nxp.com](mailto:salesaddresses@nxp.com)



## 18. Contents

<b>1</b>	<b>General description</b> .....	<b>1</b>
<b>2</b>	<b>Features and benefits</b> .....	<b>1</b>
<b>3</b>	<b>Ordering information</b> .....	<b>1</b>
<b>4</b>	<b>Functional diagram</b> .....	<b>2</b>
<b>5</b>	<b>Pinning information</b> .....	<b>3</b>
5.1	Pinning .....	3
5.2	Pin description .....	3
<b>6</b>	<b>Functional description</b> .....	<b>4</b>
<b>7</b>	<b>Limiting values</b> .....	<b>4</b>
<b>8</b>	<b>Recommended operating conditions</b> .....	<b>5</b>
<b>9</b>	<b>Static characteristics</b> .....	<b>5</b>
<b>10</b>	<b>Dynamic characteristics</b> .....	<b>7</b>
<b>11</b>	<b>Waveforms</b> .....	<b>8</b>
<b>12</b>	<b>Application information</b> .....	<b>10</b>
	RC oscillator timing component limitations .....	10
<b>13</b>	<b>Package outline</b> .....	<b>12</b>
<b>14</b>	<b>Abbreviations</b> .....	<b>14</b>
<b>15</b>	<b>Revision history</b> .....	<b>14</b>
<b>16</b>	<b>Legal information</b> .....	<b>15</b>
16.1	Data sheet status .....	15
16.2	Definitions .....	15
16.3	Disclaimers .....	15
16.4	Trademarks .....	16
<b>17</b>	<b>Contact information</b> .....	<b>16</b>
<b>18</b>	<b>Contents</b> .....	<b>17</b>

Please be aware that important notices concerning this document and the product(s) described herein, have been included in section 'Legal information'.

© NXP B.V. 2012.

All rights reserved.

For more information, please visit: <http://www.nxp.com>

For sales office addresses, please send an email to: [salesaddresses@nxp.com](mailto:salesaddresses@nxp.com)

Date of release: 25 June 2012

Document identifier: HEF4541B