



FP-1000

Thermal Printer User's Manual

Standard Model	FP-1000
Built-in Power Supply Model	FP-1000PW

Fujitsu Isotec Limited.

KA02066-Y900-04

4. Preparation

No printer cable is provided with the product. Obtain a printer cable suitable for the product interface. If you have any question, consult your dealer. Before connecting or disconnecting cables, make sure of the following:

- (1) The power to the printer and all other devices connected to the printer is turned off.
- (2) The AC adapter power cable has been unplugged from the outlet.

⚠ Caution: When connecting cables or moving the printer, hold the middle part of the printer cover on both sides. Holding the top cover may cause it to open.

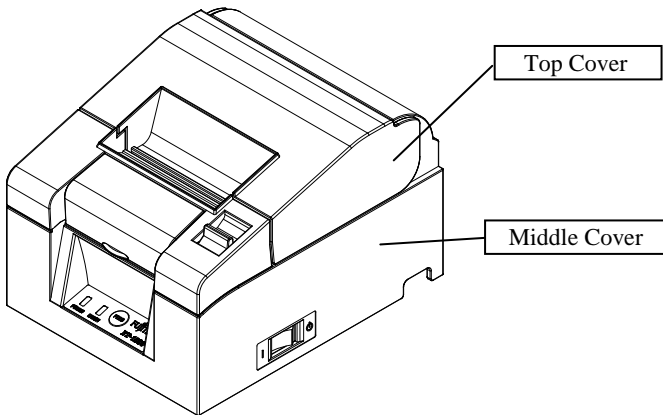

4-1. Connecting the Interface Cable (to the printer)

4-1-1 Printers with serial and USB interfaces

Standard Model

USB Interface Cable Type-B

* Connect the printer to a PC through this connector.

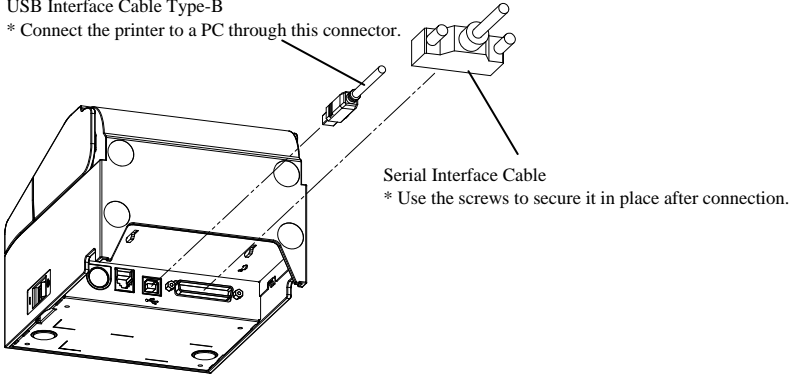

Built-in Power Supply Model

USB Interface Cable Type-B

* Connect the printer to a PC through this connector.

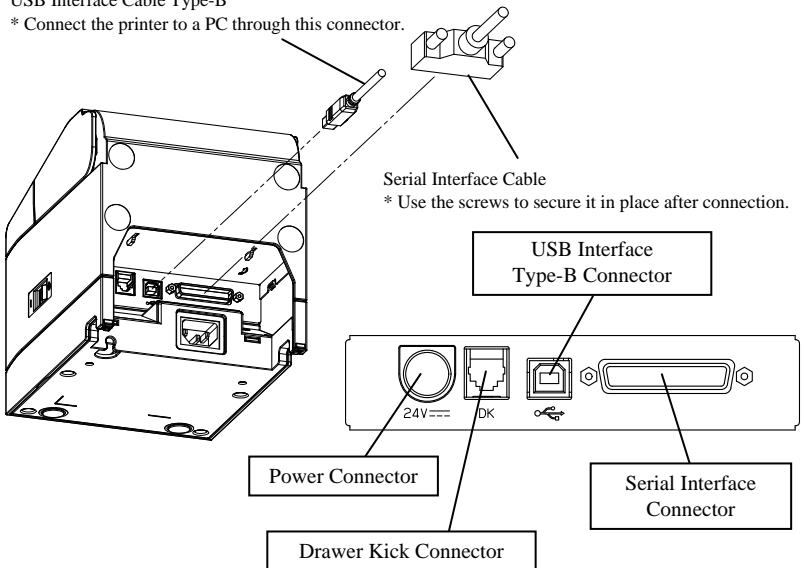

⚠ Caution: Do not connect both the serial and USB interfaces at the same time.

4-1-2 Printers with LAN interfaces

Standard Model

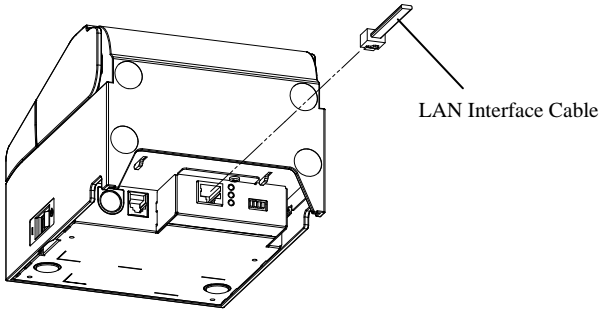

Built-in Power Supply Model

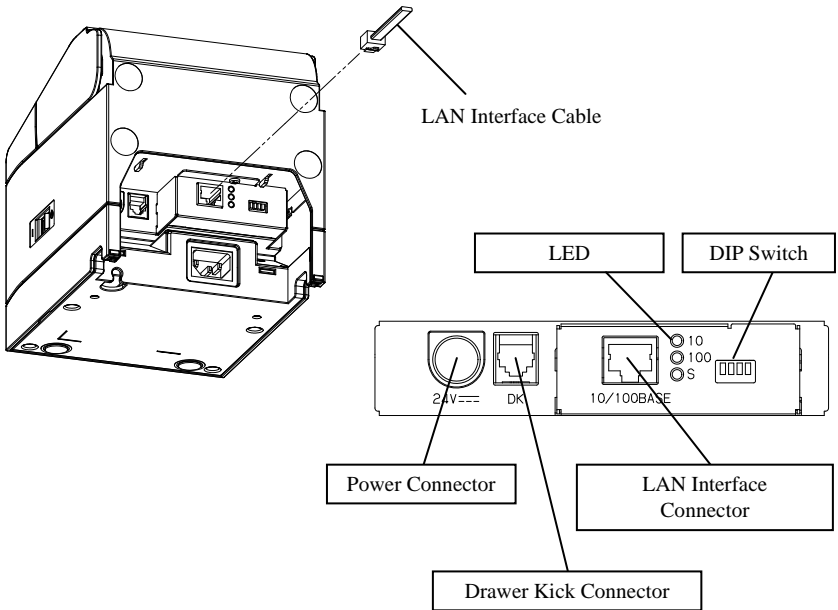

- ⚠ **Caution:** Do not touch the DIP switches during normal use. This may change the network settings, disabling normal printing.
- ⚠ **Caution:** If the device is installed vertically, the LAN cable may be un-usable due to its shape. Please check before installing.

4-2. Connecting the Interface Cable (to the PC)

4-2-1 Serial Interface

- (1) Connect the connector of serial interface cable to the serial port on the computer as shown in the figure.

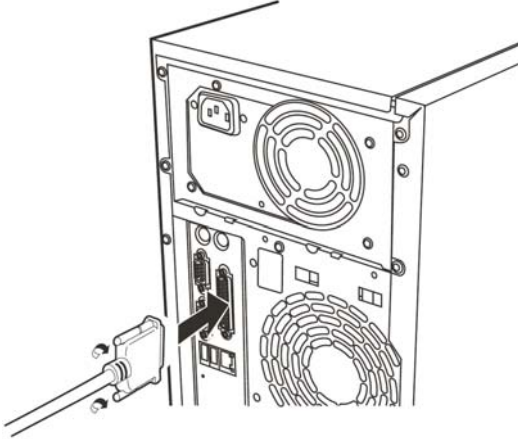

4-2-2 USB Interface

- (1) Connect the connector of USB interface cable to the USB port on the computer as shown in the figure.

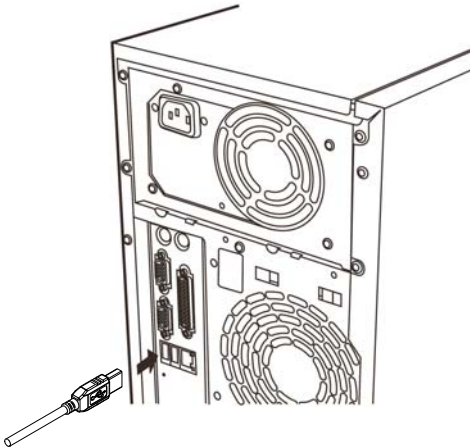

4-2-3 LAN Interface

- (1) Connect the connector of LAN interface cable to the LAN port on the computer as shown in the figure.

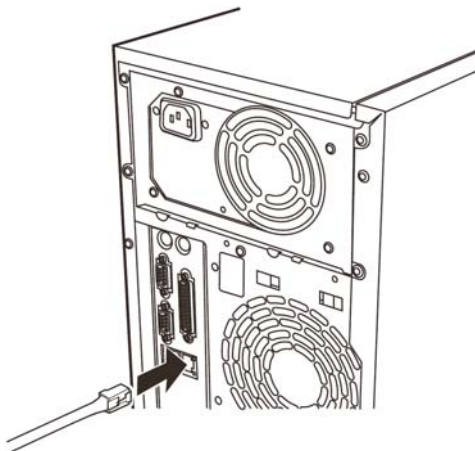

4-3. Connecting the Drawer Kick Cable

Standard Model

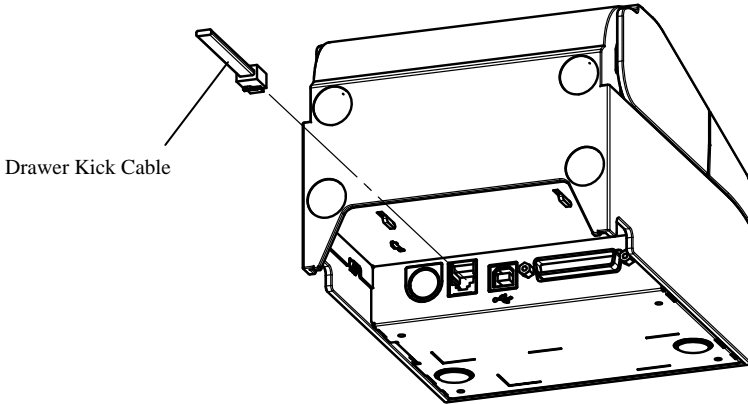

Built-in Power Supply Model

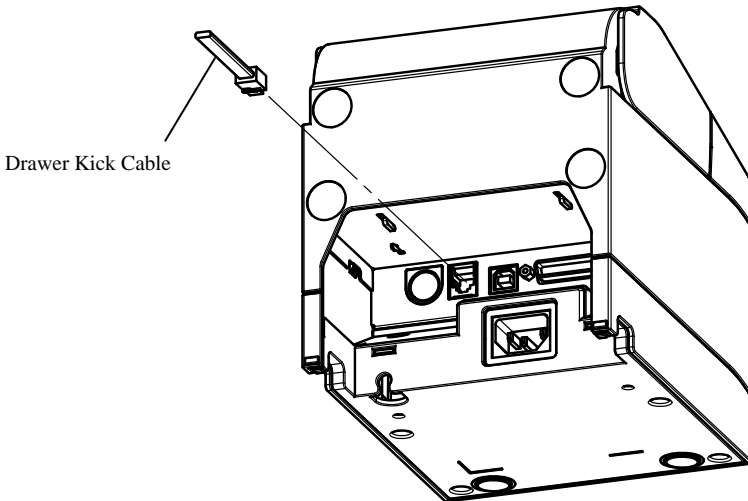

⚠ Caution: This product uses a special-purpose modular connector for the cash drawer. Do not attempt to use other types of connectors such as public telephone connectors.

4-4. Connecting the AC Adapter and Cable

Standard Model

- (1) Connect the cable connector of the AC adapter to the power connector.

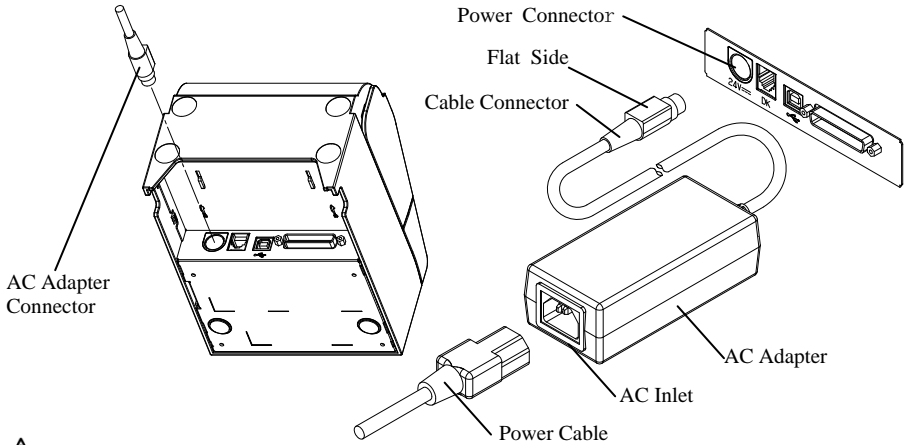

⚠ Warning: Use the specified AC adapters.

⚠ Warning: Use only the specified AC power cable with specifications based on national regulations.

⚠ Caution: Before connecting the AC adapter, turn off the power switches on the printer and all the devices connected to the printer. Also, remove the plug of the AC adapter power cable from the outlet.

⚠ Caution: Perform the adapter connection with the device placed vertically for easy operation.

⚠ Caution: As the connector is clipped in place after insertion in order to prevent it from falling off, when performing insertion, (1) grip the cable base with one hand, (2) slide the outer part of the connector upwards with the other hand (3) and push in until it locks into place.

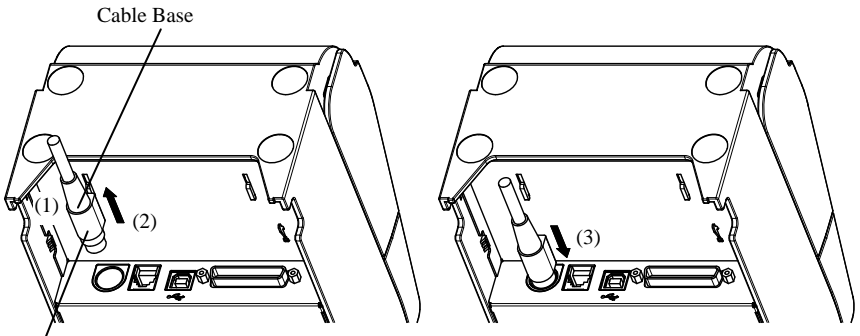

The Outer Section of the Connector

- (2) Confirm that the cable is locked in place by gently pulling on the cable base after connection.

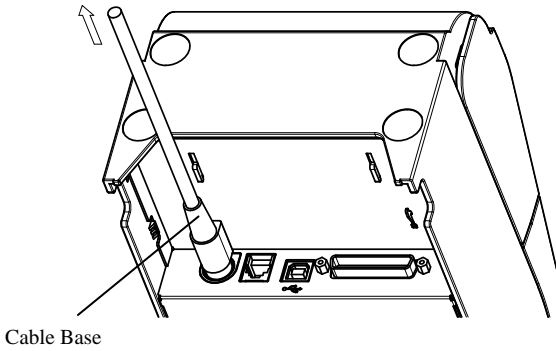

- (3) Connect the power connector to the AC inlet of the AC adapter.

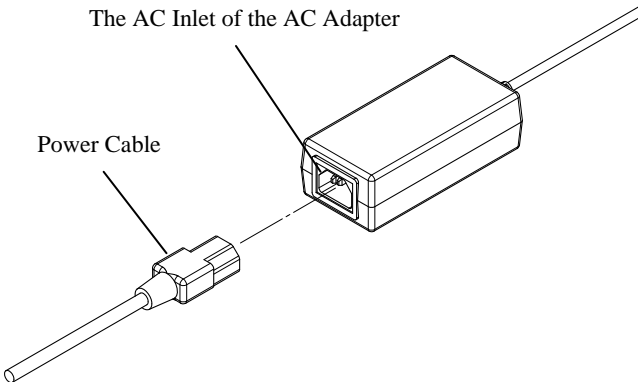

- (4) Insert the plug of the power cable into the outlet.

Built-in Power Supply Model

- (1) Connect the power connector to the AC inlet.

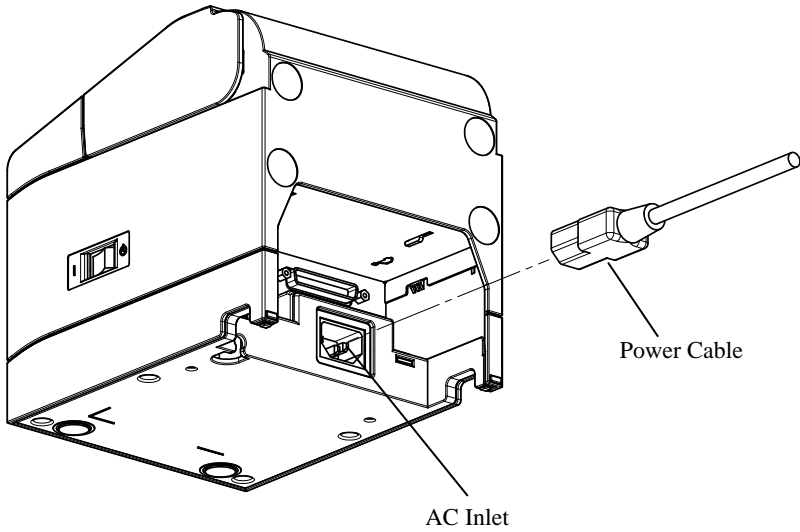

- ⚠ Warning:** Use only the specified AC power cable with specifications based on national regulations.
- ⚠ Caution:** Before connecting the power cable, turn off the power switches on the printer and all the devices connected to the printer. Also, remove the plug of the power cable from the outlet.
- ⚠ Caution:** Perform power cable connection with the device placed vertically for easy operation.
- ⚠ Caution:** If the device is installed vertically, use a right-angled power cable.

- (2) Insert the plug of the power cable into the outlet.

4-5. Removing the AC Adapter

To remove the cable of the AC adapter, pull it while gripping the connector section on the cable side as shown in the following figure. The lock is released, making it easy to remove. Forcibly pulling the cable will damage the connector section.

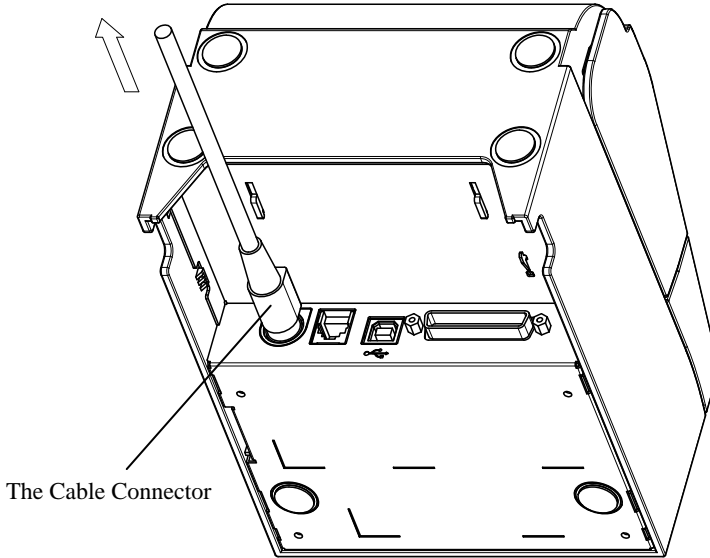

- ⚠ Caution:** Before removing the AC adapter, turn off the power switches on the printer and all the devices connected to the printer. Also, remove the plug of the AC adapter power cable from the outlet.
- ⚠ Caution:** Perform adapter removal with the device placed vertically for easy operation.

4-6. Installing the Printer

Both horizontal installation (the paper exit is on the topside) and vertical installation (the paper exit is on the front side) orientations are available.

In the case of vertical installation, attaching the optional splash-proof cover can protect the printer from water.

The printer can also be fixed to the wall by using the optional wall-hanging bracket.

Horizontal Installation

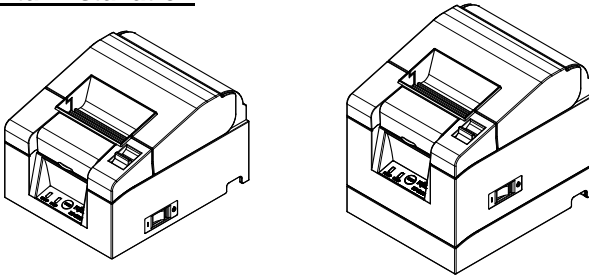

Vertical Installation

If the printer is installed vertically, stick the rubber feet (included in the package) into the round indents on the printer rear cover.

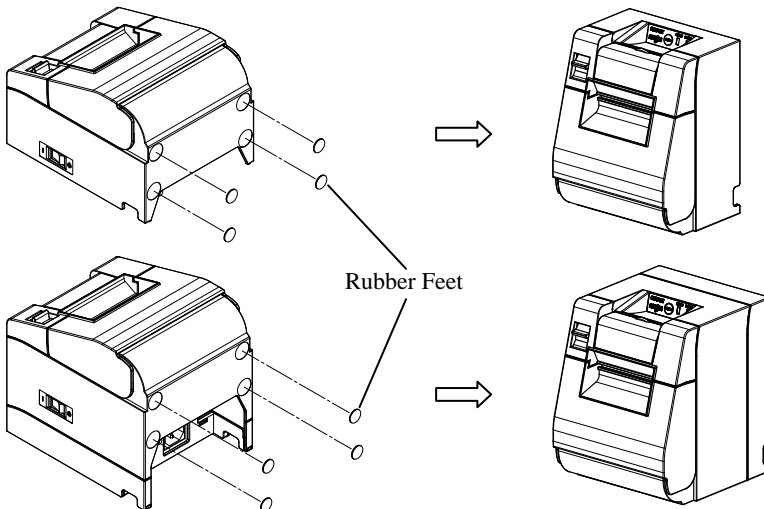

⚠ Caution: Before sticking on the rubber feet, wipe off any dirt inside the indents.

Splash-proof Cover (Optional)

Mount the splash-proof cover at the top when the printer is installed vertically.

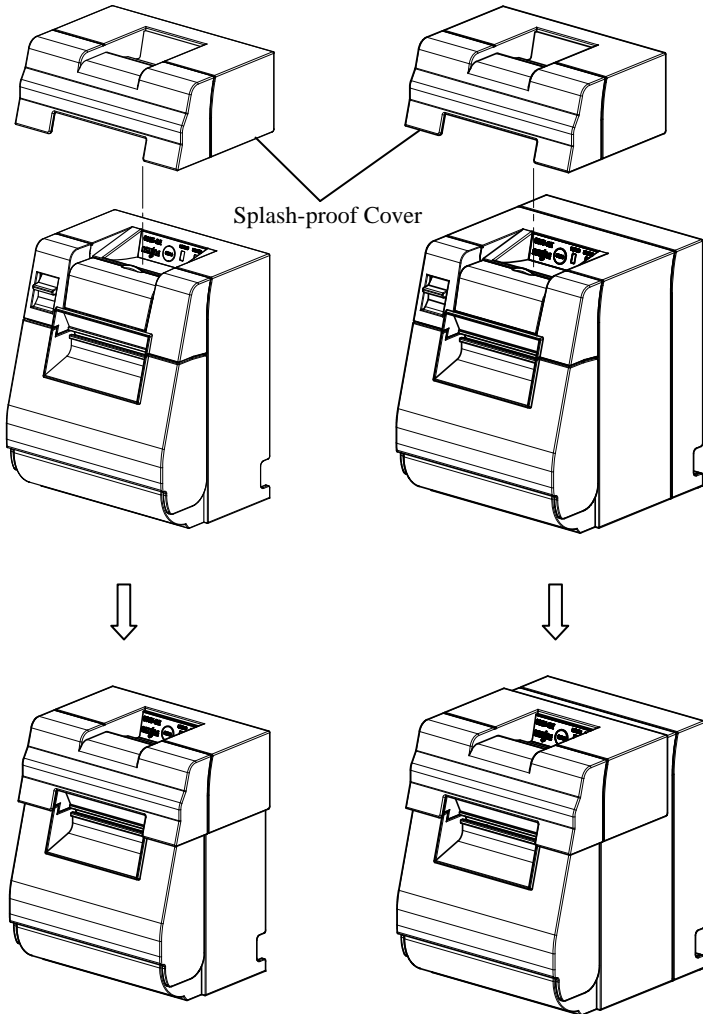

⚠ Caution: The splash-proof cover is used only for vertical installation.

Wall Hanging Bracket (Optional)

To fix the printer to a wall, follow the procedures below:

- (1) Mount two metal screws (thread diameter: $\Phi 4$, head diameter: $\Phi 7$) on the wall, spaced 62mm apart in a horizontal line, such that the length of each screw entering the wall is at least 10mm and the length protruding outside is 2-4mm.

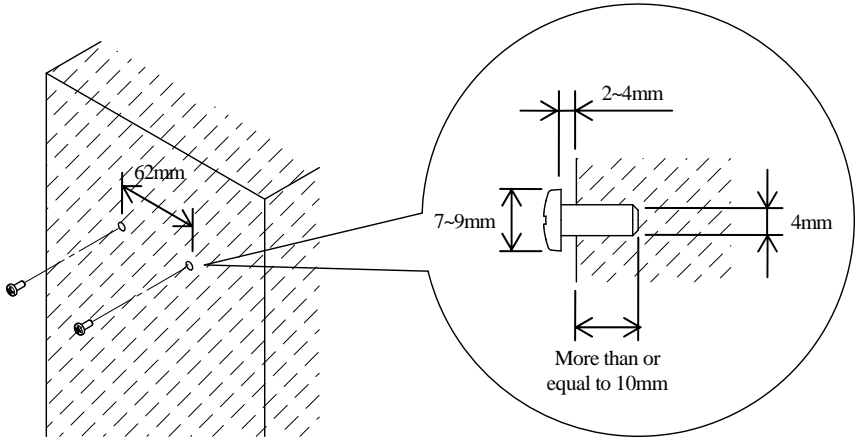

⚠ Caution: In order to firmly fix the printer, mount the wall hanging bracket onto a wooden, concrete or metal wall. It is recommended that the wall thickness should be 10mm or more.

Use metal screws.

The screws mounted on the wall are required to have a pull-out strength of 150N (15.3kgf) or more.

⚠ Caution: The wall hanging bracket can be used only for printers that use an external AC adapter (Standard Model).

- (2) Attach the wall hanging bracket to the printer and fix it securely with the enclosed screws.

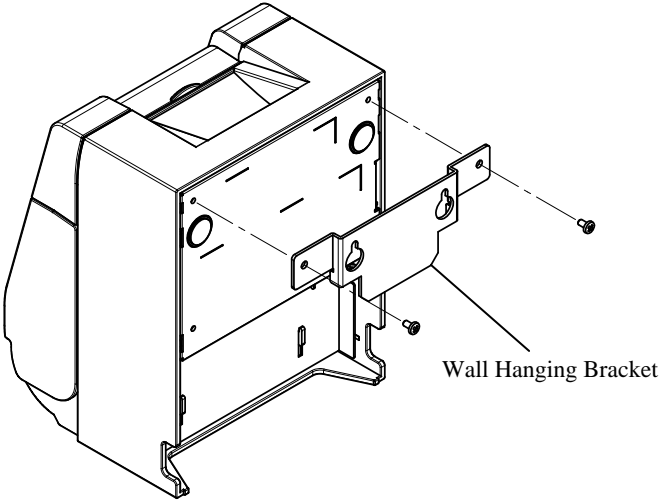

- (3) Align the holes of the wall hanging bracket with the screws mounted to the wall and hang the printer securely.

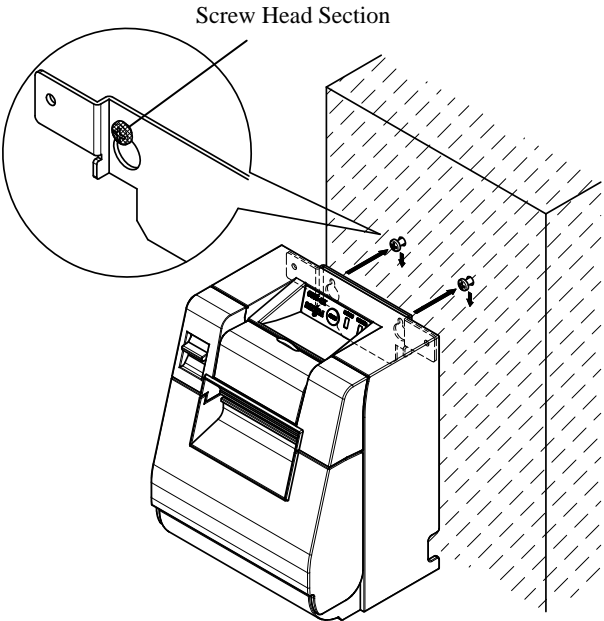

4-7. Power On

- (1) Connect to the power cable according to 4-4 above.
- (2) Turn on the power switch at the side of the printer.
After turning the power on, the POWER lamp on the control panel will light up.

Standard Model

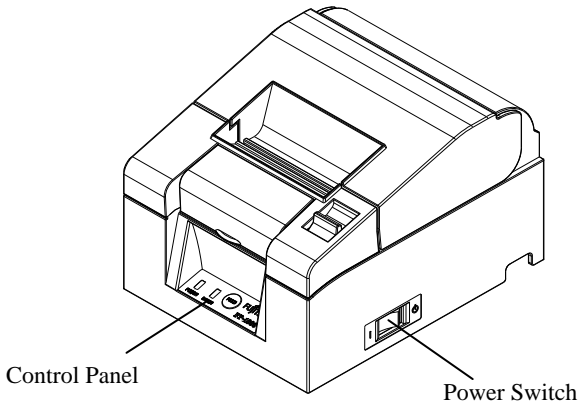

Built-in Power Supply Model

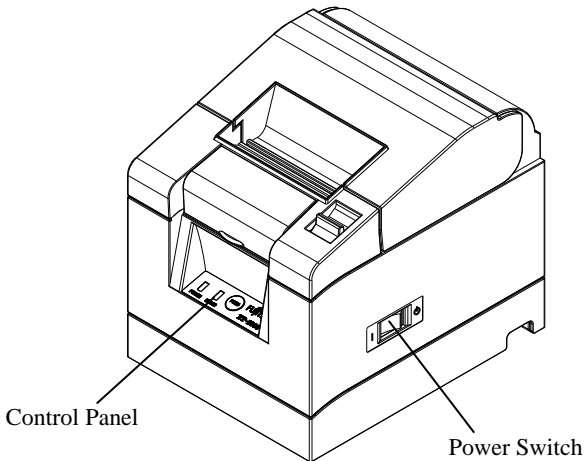

4-8. Installing the Printer Software

Refer to the "Installation Guide"(*1) in the enclosed CD for instructions on installing the printer driver and utility software.

*1: \Manual\Software\English\FP1000_InstallGuide1_en.pdf

The "Installation Guide" can also be viewed by loading the CD in your PC's CD drive and selecting "Manuals" on the "Thermal Printer Setup" screen that appears.

11. Interface

11-1. Serial Interface

(1) Transmission Interface Specifications

Transmission Method	Asynchronous
Line Type	Full duplex
Input/Output Circuit	Input: MAX211 Equivalent Output: MAX211 Equivalent
Baud Rate	2400, 4800, 9600, 19200, 38400, 57600, 115200BPS (Setup Settings)
Transmission Code Type	7 or 8 bits
Transmission Code Format	Start bits: 1 bit Stop bits: 1 bit Data bits: 7 or 8 bits (Setup Settings) Parity: NONE, ODD, EVEN (Setup Settings) Mark(1) <div style="display: flex; align-items: center; gap: 5px;"> ST b0 b1 b2 b3 b4 b5 b6 b7 PT SP </div> Space(0)
Transmission Sequence	LSB to MSB
Transmission Code	JIS code
Error Control	Parity check (Setup Settings)
Connection Line Length	Max. 15m: (When power is supplied from the power connector) Max. 2m: (When power is supplied from the interface connector)
Protocol	DSR/DTR, XON/XOFF (Setup Settings)

(2) Serial Interface Connector

Pin No.	Signal Name	Direction	Signal Line Name
1	SG	-	Signal Ground
2	TXD	Output	Transmit Data
3	RXD	Input	Receive Data
4	RTS	Output	Request to Send
5	CTS	Input	Clear to Send
6	DSR	Input	Data Set Ready
7	SG	-	Signal Ground
8~12	N.C	-	No Connection
13	SG2	-	+24V Ground
14	SG2	-	+24V Ground
15~17	N.C	-	No Connection
18	+24V	-	Mechanical Drive Power
19	+24V	-	Mechanical Drive Power
20	DTR	Output	Data Terminal Ready
21~24	N.C	-	No Connection
25	INIT	Input	Forcible Reset Signal

⚠ Caution: When the power is supplied from the power connector, ensure the pins shaded in grey are not connected.

⚠ Caution: Use a lock screw with an imperial thread on the connector.

(3) Connection Cable

The connection setup shown in the following figure is recommended.

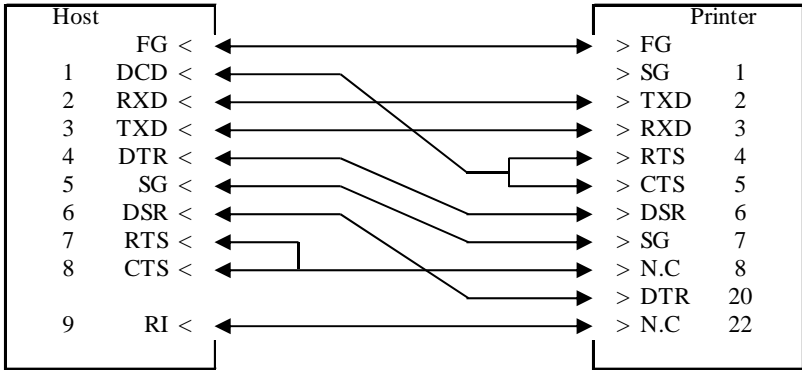

⚠ Caution: Supplying power from the interface connector is prohibited.

11-2. USB Interface

(1) Type-B Connector: 4 Pins

Pin No.	Signal Name	Direction	Signal Line Name
1	VBUS	Input	VBUS
2	D-inB	Input/Output	D-
3	D+inB	Input/Output	D+
4	SG	-	Signal Ground

⚠ Caution: Use a shielded USB cable.

11-3. LAN Interface

(1) LAN Interface Connector

Pin No.	Signal Name	Direction	Signal Line Name
1	TX+	Output	Output data
2	TX-	Output	Output data
3	RX+	Input	Input data
4	N.C	-	-
5	N.C	-	-
6	RX-	Input	Input data
7	N.C	-	-
8	N.C	-	-

(2) LED

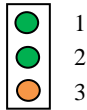

No.	Meaning	Description
1	10BASE-T Link	Lights up when the connection is recognized as 10BASE-T
2	100BASE-TX Link	Lights up when the connection is recognized as 100BASE-TX
3	Status	Lights up for a period of time (50msec) when packets are received

(3) DIP Switches

⚠ Caution: These switches are for maintenance. During normal usage, leave them all in the OFF state.

No.	ON	OFF
1	-	Off (Fixed)
2	Settings Information Initialization	-
3	Settings Information	-
4	Self-diagnosis Print	-

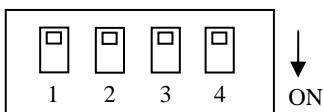

Procedures for Settings Initialization

- 1) Turn off the printer power.
- 2) Set No.2 DIP switch to ON.
- 3) Turn on the printer power. Initialization takes about five seconds.
- 4) Turn off the printer power.
- 5) Set No.2 DIP switch to OFF.

Procedures for Test Print from LAN Board

- 1) Turn off the printer power.
- 2) Set No.3 and No.4 DIP switches to ON.
- 3) As soon as the printer power is turned on, a test print is performed.
- 4) Turn off the printer power.
- 5) Set No.3 and No.4 DIP switches to OFF.

⚠ Caution: Be careful with DIP switch operations.

11-4. Drawer Kick Connector

Pin No.	Signal Name	Direction	Signal Line Name
1	FG	-	Frame Ground
2	*DRD1	Output	Drawer Kick Drive Signal 1
3	DRSNS1	Input	Drawer Sense Signal 1
4	+24V	-	Drive Power
5	*DRD2	Output	Drawer Kick Drive Signal 2
6	SG	-	Signal Ground

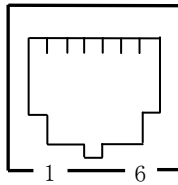

<Connecting side>

<Connection>

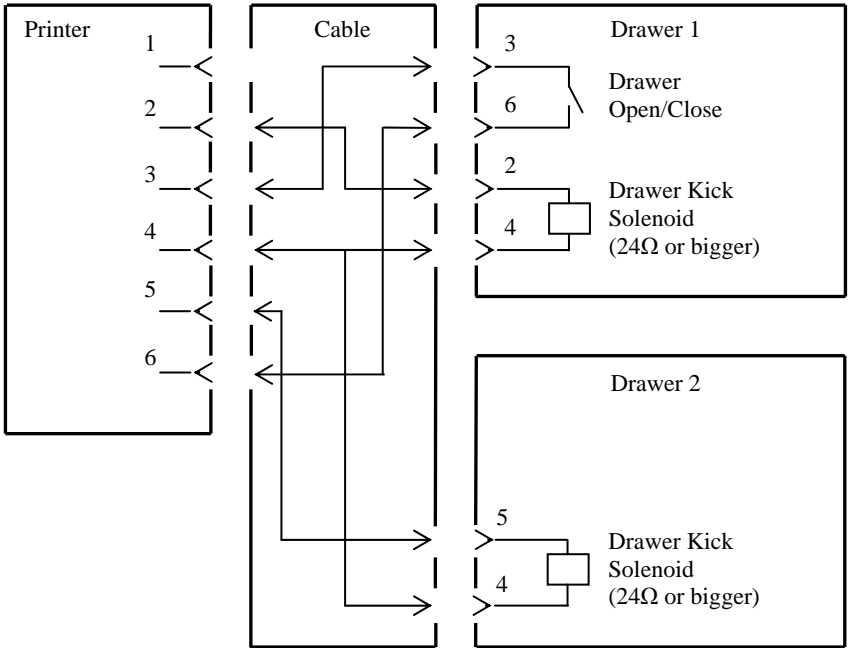

- ⚠ **Caution:** The drawer connection cable should be of the shielded type.
- ⚠ **Caution:** Simultaneous drive from the two drives is not available.
- ⚠ **Caution:** Specify the ON time and OFF time (t1 and t2) for the drawer using the pulse generation command (ESC p m t1 t2).
- ⚠ **Caution:** Set the drive duty cycle for the drawer in accordance with the following formula: ON time/(ON time + OFF time) ≤ 0.2
- ⚠ **Caution:** Always use printer power (connector pin 4) for the drawer power.
- ⚠ **Caution:** Use a drawer kick solenoid with a resistance value of at least 24Ω. If it is under 24Ω, the solenoid may be damaged by excess current.
- ⚠ **Caution:** This product uses a special-purpose modular connector for the cash drawer and customer display connector. Do not attempt to use other types of connectors such as public telephone connectors.

11-5. Power Specifications

(1) Standard Model

Operating Voltage: 24V \pm 10%
 Operating Current: 1.5A
 Power Consumption: During standby: 3.0W or less/0.1A (Dual Interface)
 4.5W or less/0.1A (LAN Interface)
 During operation: 38W or less /1.5A
 (at 25°C, print density setting 100%, paper width 80mm, print duty 9%)

(2) Built-in Power Supply Model

Rated Input Voltage: 100-240V, 50-60Hz
 Rated Input Current: 1.1A
 Power Consumption: During standby: 3.0W or less/0.1A (Dual Interface)
 4.5W or less/0.1A (LAN Interface)
 During operation: 38W or less /1.5A
 (at 25°C, print density setting 100%, paper width 80mm, print duty 9%)

Note: Drawer Kick Drive Current: Max. 1A

However, do not operate two drawer kick at the same time.

Power Connector Pin Assignment

Pin No.	Signal Name
1	+24V
2	SG
3	N.C

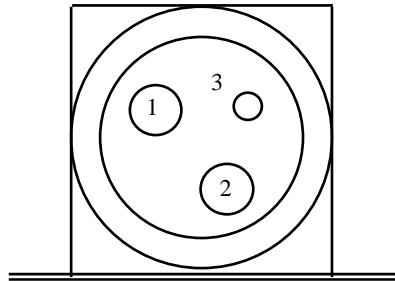

⚠ Warning: Use the specified AC adapter for the power supply.
(If our AC adapter is not used, problems such as bad print quality, electromagnetic interference, or circuit noise may occur.)

FUJITSU