

■ Features :

1. Chip Material: AlGaInP/InGaN/InGaN
2. Lens Color: Water Clear
3. Source Color: Red/True Green/Blue
4. Pb free.
5. The product itself will remain within RoHS compliant version.

■ Package Dimensions:

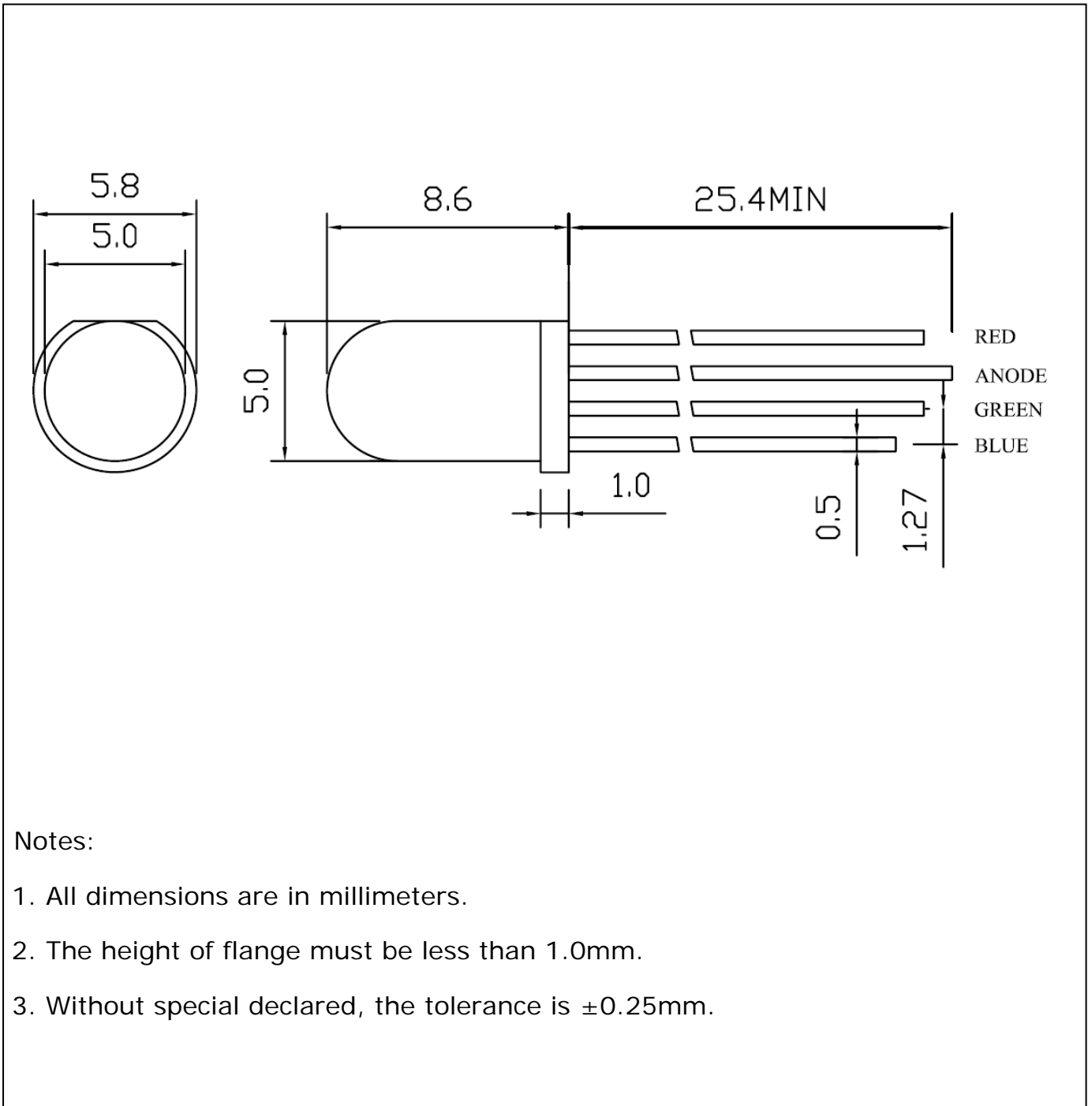

Notes:

1. All dimensions are in millimeters.
2. The height of flange must be less than 1.0mm.
3. Without special declared, the tolerance is ± 0.25 mm.

■ Absolute Maximum Ratings at Ta=25°C: (R)

Parameter	Symbol	Maximum	Unit
Power Dissipation	Pd	75	mW
Peak Forward Current (Duty 1/10 @1KHz)	IFP	100	mA
Forward Current	IF	30	mA
Reverse Voltage	VR	5	V
Operating Temperature Range	Topr	-25°C to +80°C	
Storage Temperature Range	Tstg	-40°C to +100°C	
Lead Soldering Temperature [2.0mm from body]	Tsol	Reflow Soldering : 260 °C for 10 sec. Hand Soldering : 350 °C for 3 sec.	

■ Electrical/Optical Characteristics at Ta=25°C: (R)

Parameter	Symbol	Test Condition	Min.	Typ.	Max.	Unit
Luminous Intensity	Iv	IF=20mA	1000	2000	—	mcd
Dominant Wavelength	λ_d	IF=20mA	620	—	630	nm
Viewing Angle	2 θ 1/2	IF=20mA	—	30	—	deg
Forward Voltage	VF	IF=20mA	1.8	—	2.6	V
Reverse Current	IR	VR=5V	—	—	10	uA

Notes:

- 1.Tolerance of Luminous Intensity $\pm 10\%$
- 2.Tolerance of Forward Voltage $\pm 0.1V$

■ Absolute Maximum Ratings at Ta=25°C: (G)

Parameter	Symbol	Maximum	Unit
Power Dissipation	Pd	100	mW
Peak Forward Current (Duty 1/10 @1KHz)	IFP	120	mA
Forward Current	IF	30	mA
Reverse Voltage	VR	5	V
Operating Temperature Range	Topr	-25°C to +80°C	
Storage Temperature Range	Tstg	-40°C to +100°C	
Lead Soldering Temperature [2.0mm from body]	Tsol	Reflow Soldering : 260 °C for 10 sec. Hand Soldering : 350 °C for 3 sec.	

■ Electrical/Optical Characteristics at Ta=25°C: (G)

Parameter	Symbol	Test Condition	Min.	Typ.	Max.	Unit
Luminous Intensity	Iv	IF=20mA	3000	5000	—	mcd
Dominant Wavelength	λ_d	IF=20mA	515	—	525	nm
Viewing Angle	2 θ 1/2	IF=20mA	—	30	—	deg
Forward Voltage	VF	IF=20mA	2.8	—	3.6	V
Reverse Current	IR	VR=5V	—	—	10	uA

Notes:

- 1.Tolerance of Luminous Intensity $\pm 10\%$
- 2.Tolerance of Forward Voltage $\pm 0.1V$

■ Absolute Maximum Ratings at Ta=25°C: (B)

Parameter	Symbol	Maximum	Unit
Power Dissipation	Pd	100	mW
Peak Forward Current (Duty 1/10 @1KHz)	IFP	120	mA
Forward Current	IF	30	mA
Reverse Voltage	VR	5	V
Operating Temperature Range	Topr	-25°C to +80°C	
Storage Temperature Range	Tstg	-40°C to +100°C	
Lead Soldering Temperature [2.0mm from body]	Tsol	Reflow Soldering : 260 °C for 10 sec. Hand Soldering : 350 °C for 3 sec.	

■ Electrical/Optical Characteristics at Ta=25°C: (B)

Parameter	Symbol	Test Condition	Min.	Typ.	Max.	Unit
Luminous Intensity	Iv	IF=20mA	1000	2000	—	mcd
Dominant Wavelength	λ_d	IF=20mA	460	—	470	nm
Viewing Angle	2 θ 1/2	IF=20mA	—	30	—	deg
Forward Voltage	VF	IF=20mA	2.8	—	3.6	V
Reverse Current	IR	VR=5V	—	—	10	uA

Notes:

- 1.Tolerance of Luminous Intensity $\pm 10\%$
- 2.Tolerance of Forward Voltage $\pm 0.1V$

■ Reliability test items and conditions:

The reliability of products shall be satisfied with items listed below.

Confidence level: 97%

LTPD: 3%

No	Item	Test Conditions	Test Hours/Cycle	Sample Size	Failure Judgment Criteria	Ac/Re
1	Solder Heat	TEMP : 260°C \pm 5°C	10 SEC	76 PCS	$I_v \leq I_{vt} * 0.5$ or $V_f \geq U$ or $V_f \leq L$	0/1
2	Temperature Cycle	H : +100°C 15min \int 5 min L : -40°C 15min	300 CYCLES	76 PCS		0/1
3	Thermal Shock	H : +100°C 5min \int 10 sec L : -40°C 5min	300 CYCLES	76 PCS		0/1
4	High Temperature Storage	TEMP : 100°C	1000 HRS	76 PCS		0/1
5	Low Temperature Storage	TEMP : -40°C	1000 HRS	76 PCS		0/1
6	DC Operating Life	TEMP : 25°C $I_F = 20mA$	1000 HRS	76 PCS		0/1
7	High Temperature / High Humidity	85°C / 85% RH	1000 HRS	76 PCS		0/1

Note:

I_{vt}: To test I_v value of the chip before the reliability test

I_v: The test value of the chip that has completed the reliability test

U: Upper Specification Limit

L: Lower Specification Limit

■ Precautions:

TAKE NOTE OF THE FOLLOWING IN USE OF LED

1. Temperature in use

Since the light generated inside the LED needs to be emitted to outside efficiently, a resin with high light transparency is used; therefore, additives to improve the heat resistance or moisture resistance (silica gel, etc) which are used for semiconductor products such as transistors cannot be added to the resin.

Consequently, the heat resistant ability of the resin used for LED is usually low; therefore, please be careful on the following during use.

Avoid applying external force, stress, and excessive vibration to the resins and terminals at high temperature. The glass transition temperature of epoxy resin used for the LED is approximately 120-130°C.

At a temperature exceeding this limit, the coefficient of linear expansion of the resin doubles or more compared to that at normal temperature and the resin is softened.

If external force or stress is applied at that time, it may cause a wire rupture.

2. Soldering

Please be careful on the following at soldering.

After soldering, avoid applying external force, stress, and excessive vibration until the products go to cooling process (normal temperature), <Same for products with terminal leads>

(1) Soldering measurements:

Distance between melted solder side to bottom of resin shall be 1.6mm or longer.

(2) Dip soldering :

Pre-heat: 90°C max. (Backside of PCB), Within 60 seconds.

Solder bath: 260±5°C (Solder temperature), Within 5 seconds.

(3) Hand soldering: 350°C max. (Temperature of soldering iron tip), Within 3 seconds.

3. Insertion

Pitch of the LED leads and pitch of mounting holes need to be same.

4. Others

Since the heat resistant ability of the LED resin is low, SMD components are used on the same PCB, please mount the LED after adhesive baking process for SMD components. In case adhesive baking is done after LED lamp insertion due to a production process reason, make sure not to apply external force, stress, and excessive vibration to the LED and follow the conditions below.

Baking temperature: 120°C max. Baking time: Within 60 seconds.

If soldering is done sequentially after the adhesive baking, please perform the soldering after cooling down the LED to normal temperature.