



深圳秋田微电子有限公司
SHENZHEN AV-DISPLAY CO.,LTD.

深圳秋田微电子有限公司
地址：深圳市龙岗区横岗镇荷坳金源工业区金源路 39 号

电话:(086)0755-88860696 传真:(086)0755-26911092
网址: [Http://www.av-display.com.cn](http://www.av-display.com.cn)

SHENZHEN AV-DISPLAY CO.,LTD
Address: No. 39, Jinyuan Road, He'ao Jinyuan industrial zone, Henggang Town, Long Gang district, Shenzhen, China
TEL: (086)0755-88860696 FAX: (086)0755-26911092
[Http://www.av-display.com.cn](http://www.av-display.com.cn)

**SPECIFICATION
FOR
LCM MODULE**

**MODULE NO.: ABC016002A10-GHW-R
DOC.REVISION 00**

Customer Approval:

--

	SIGNATURE	DATE
PREPARED BY (RD ENGINEER)		Dec-30-2007
PREPARED BY (QA ENGINEER)		
CHECKED BY		
APPROVED BY		



深圳秋田微电子有限公司
SHENZHEN AV-DISPLAY CO.,LTD.

DOCUMENT REVISION HISTORY

Version	DATE	DESCRIPTION	CHANGED BY
00	Dec-30-2007	First issue	Dong



深圳秋田微电子有限公司
SHENZHEN AV-DISPLAY CO.,LTD.

CONTENTS

1. Functions & Features	1
2. Mechanical specifications	1
3. Block diagram	1
4. Dimensional Outline	2
5. Pin description	3
6. Maximum absolute limit	3
7. Electrical characteristics	3
8. Backlight drawing & specification	4
9. Electro-Optical characteristics	4
10. Timing characteristics	5
11. Control and display command	6
12. Font Characteristic	7
13. Quality Specifications	8-16



1. FUNCTIONS & FEATURES

1.1. Format	: 16*2 characters
1.2. LCD mode	: STN / Positive/ Transflective / Grey
1.3. Viewing direction	: 6 o'clock
1.4. Driving scheme	: 1/16 Duty , 1/5 Bias
1.5. Power supply voltage (V _{DD})	: 5.0V
1.6. LCD driving voltage(V _{op})	: 4.2V
1.7. Operation temp	: -20~70°C
1.8. Storage temp	: -30~80°C
1.9. Backlight color	: Edge, White(2PCS SMD 4.0V 30mA)
1.10. RoHS standard	

2. MECHANICAL SPECIFICATIONS

2.1. Module size	: 80.0mm(L)*36.0mm(W)* 14.5mm(H)max
2.2. Viewing area	: 62.2mm(L)*17.9mm(W)
2.3. Character pitch	: 3.55mm(L)*5.95mm(W)
2.4. Character size	: 2.95mm(L)*5.55mm(W)
2.5. Dot pitch	: 0.60mm(L)*0.70mm(W)
2.6. Dot size	: 0.55mm(L)*0.65mm(W)
2.7. Weight	: Approx.

3. BLOCK DIAGRAM

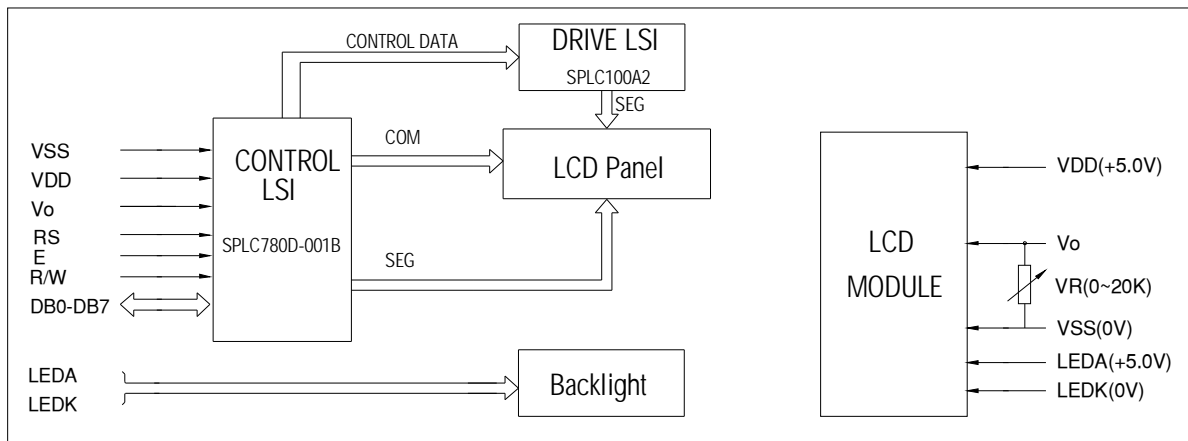

Figure 2. Block diagram



4.DIMENSIONAL OUTLINE

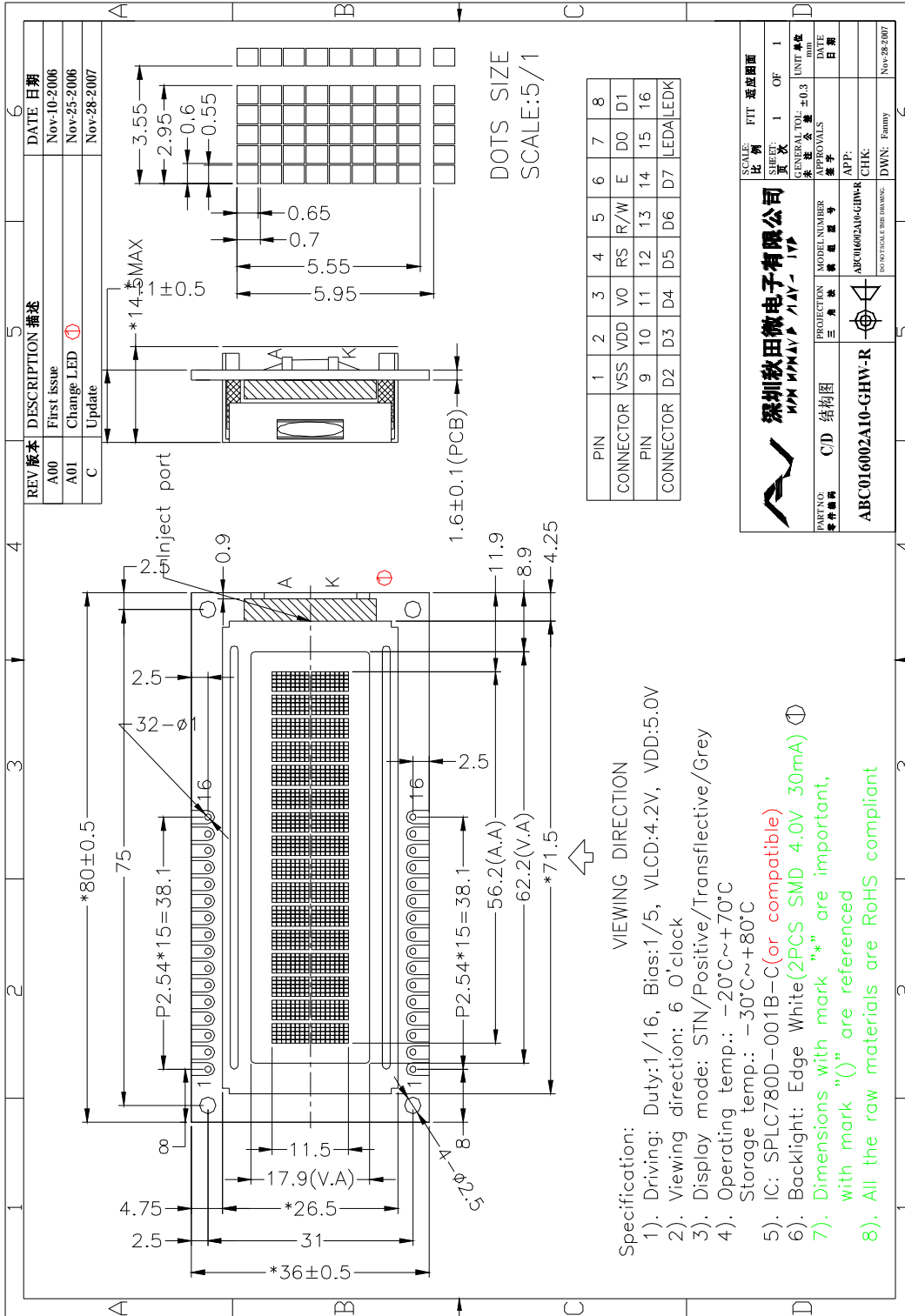



Figure 1. Dimensional outline

5. PIN DESCRIPTION

No.	Symbol	Function
1	VSS	GND(0V)
2	VDD	Power supply for Logic(+5V)
3	V0	Power supply for LCD drive
4	RS	Register selection (H: Data register, L: Instruction register)
5	R/W	Read/write selection (H: Read, L: Write)
6	E	Enable signal for LCM
7~14	DB0~DB7	Data Bus line
15	LEDA	Power supply for Backlight(+5.0V)
16	LEDK	Power supply for Backlight(0V)

6. MAXIMUM ABSOLUTE LIMIT

Item	Symbol	MIN	MAX	Unit
Supply Voltage for Logic	V _{DD}	-0.3	7.0	V
Supply Voltage for LCD	V ₀	V _{DD} -12.0	V _{DD} +0.3	V
Input Voltage	V _{in}	-0.3	V _{DD} +0.3	V
Supply Current for Backlight	I _F (T _a = 25°C)	---	30	mA
Reverse Voltage for Backlight	V _R (T _a = 25°C)	---	5	V
Operating Temperature	T _{op}	-20	70	°C
Storage Temperature	T _{st}	-30	80	°C

7. ELECTRICAL CHARACTERISTICS

Item	Symbol	Condition	Min	Typ	Max	Unit
Supply Voltage for Logic	V _{DD} -V _{SS}	T _a = 25°C	4.8	5.0	5.2	V
Input High Voltage	V _{IH}	T _a = 25°C	0.7V _{DD}	---	V _{DD}	V
Input Low Voltage	V _{IL}	T _a = 25°C	-0.3	---	0.2 V _{DD}	V
Output High Voltage(TTL)	V _{OH}	T _a = 25°C	0.75V _{DD}	---	---	V
Output Low Voltage(TTL)	V _{OL}	T _a = 25°C	---	---	0.2V _{DD}	V
Supply Current	I _{DD}	T _a = 25°C	---	---	3.0	mA



8. BACK LIGHT CHARACTERISTICS

LCD Module with Side Y-G LED Backlight
ELECTRICAL RATINGS

Ta = 25°C

Item	Symbol	Condition	Min	Typ	Max	Unit
Forward Current	IF	VF=4V	25	---	30	mA
Reverse Current	IR	Vr=5V	---	---	20	uA
Luminous Intensity (Without LCD)	Lv	VF=4V	190	---	350	Cd/m ²
Wave length	X Y	VF=4V	X=0.25 X=0.25	---	Y=0.30 Y=0.30	nm
Color	WHITE					

9. ELECTRO-OPTICAL CHARACTERISTICS

(V_{DD} = 5.0V, Ta = 25°C)

Item	Symbol	Condition	Min	Typ	Max	Unit
Operating Voltage Of LCD	Vop	Ta = -20°C	4.3	4.6	4.9	V
		Ta = 25°C	4.0	4.2	4.5	
		Ta = 70°C	3.7	3.8	4.0	
Response time	Tr	Ta = 25°C	---	185	---	ms
	Tf		---	200	---	ms
Contrast	Cr	Ta = 25°C	---	4	---	---
Viewing angle range	Φ	Cr ≥ 2	-40	---	+40	deg
	Φ		-40	---	+40	deg

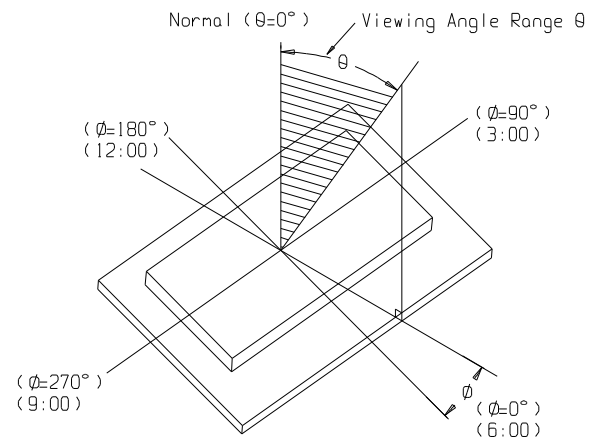
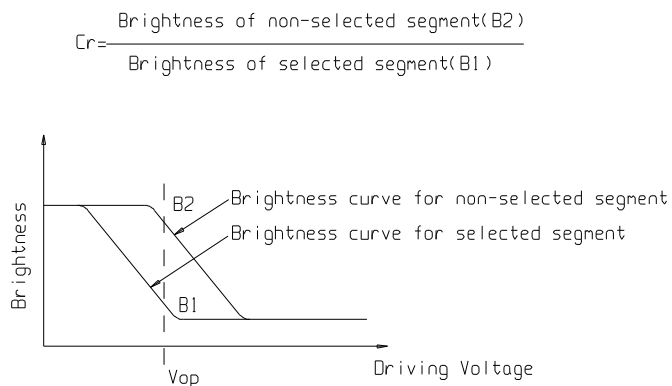



10. TIMING CHARACTERISTICS

Write mode(writing data from MPU to SPLC780D)

Characteristics	Symbol	Limit			Unit	Test Condition
		Min.	Typ.	Max.		
E Cycle Time	t_c	1000	-	-	ns	Pin E
E Pulse Width	t_{pw}	450	-	-	ns	Pin E
E Rise/Fall Time	t_r, t_f	-	-	25	ns	Pin E
Address Setup Time	t_{sp1}	60	-	-	ns	Pins: RS, R/W, E
Address Hold Time	t_{hd1}	20	-	-	ns	Pins: RS, R/W, E
Data Setup Time	t_{sp2}	195	-	-	ns	Pins: DB0 - DB7
Data Hold Time	t_{hd2}	10	-	-	ns	Pins: DB0 - DB7

Read mode(reading data from SPLC780D to MPU)

Characteristics	Symbol	Limit			Unit	Test Condition
		Min.	Typ.	Max.		
E Cycle Time	t_c	1000	-	-	ns	Pin E
E Pulse Width	t_w	450	-	-	ns	Pin E
E Rise/Fall Time	t_r, t_f	-	-	25	ns	Pin E
Address Setup Time	t_{sp1}	60	-	-	ns	Pins: RS, R/W, E
Address Hold Time	t_{hd1}	20	-	-	ns	Pins: RS, R/W, E
Data Output Delay Time	t_o	-	-	360	ns	Pins: DB0 - DB7
Data hold time	t_{hd2}	5.0	-	-	ns	Pin DB0 - DB7

Write mode timing diagram(Writing data from MPU to SPLC780D)

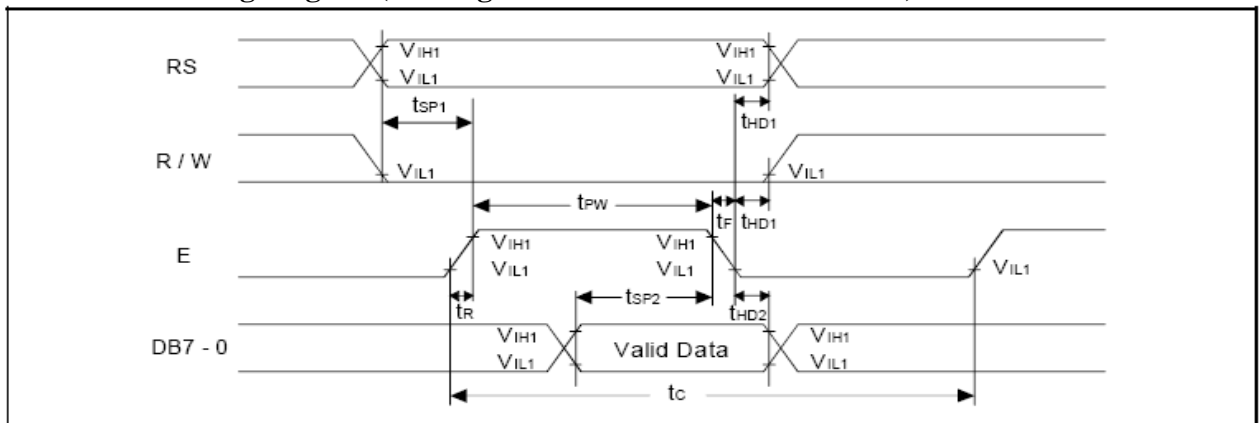

Read mode timing diagram(Reading data from SPLC780D to MPU)

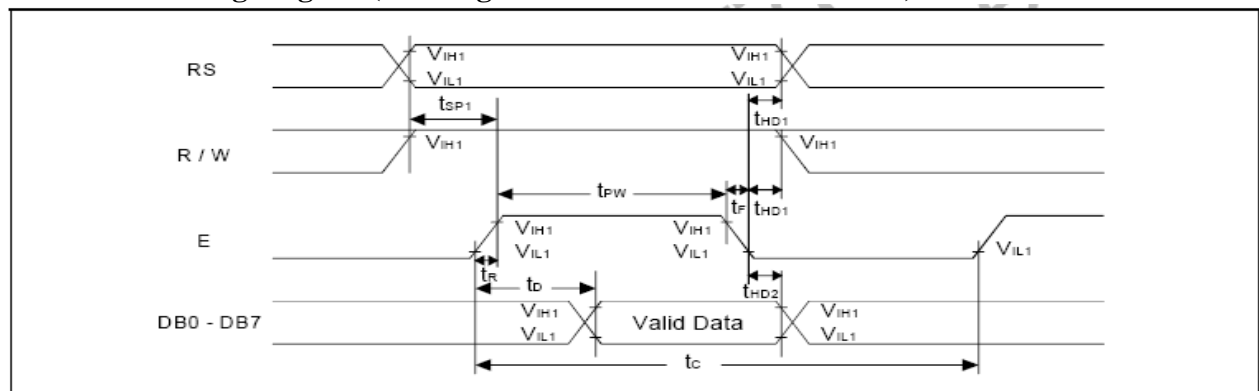



11. CONTROL AND DISPLAY COMMAND

Instruction	Instruction Code										Description	Execution time (Temp = 25°C)		
	RS	RW	DB7	DB6	DB5	DB4	DB3	DB2	DB1	DB0		Fosc=190KHz	Fosc=270KHz	Fosc=350KHz
Clear Display	0	0	0	0	0	0	0	0	0	1	Write "00H" to DDRAM and set DDRAM address to "00H" from AC.	2.15ms	1.52ms	1.18ms
Return Home	0	0	0	0	0	0	0	0	1	-	Set DDRAM address to "00H" from AC and return cursor to its original position if shifted. The contents of DDRAM are not changed.	2.16ms	1.52ms	1.18ms
Entry Mode Set	0	0	0	0	0	0	0	1	VD	S	Assign cursor moving direction and enable the shift of entire display.	53μs	38μs	29μs
Display ON/OFF Control	0	0	0	0	0	0	1	D	C	B	Set display (D), cursor(C), and blinking of cursor(B) on/off control bit.	53μs	38μs	29μs
Cursor or Display Shift	0	0	0	0	0	1	S/C	R/L	-	-	Set cursor moving and display shift control bit, and the direction, without changing of DDRAM data.	53μs	38μs	29μs
Function Set	0	0	0	0	1	DL	N	F	-	-	Set interface data length (DL: 8-bit/4-bit), numbers of display line (N: 2-line/1-line) and, display font type (F:5x10 dots/5x8 dots).	53μs	38μs	29μs
Set CGRAM Address	0	0	0	1	AC5	AC4	AC3	AC2	AC1	AC0	Set CGRAM address in address counter.	53μs	38μs	29μs
Set DDRAM Address	0	0	1	AC6	AC5	AC4	AC3	AC2	AC1	AC0	Set DDRAM address in address counter.	53μs	38μs	29μs
Read Busy Flag and Address Counter	0	1	BF	AC6	AC5	AC4	AC3	AC2	AC1	AC0	Whether during internal operation or not can be known by reading BF. The contents of address counter can also be read.			
Write Data to RAM	1	0	D7	D6	D5	D4	D3	D2	D1	D0	Write data into internal RAM (DDRAM/CGRAM).	50μs	30μs	29μs
Read Data from RAM	1	1	D7	D6	D5	D4	D3	D2	D1	D0	Read data from internal RAM (DDRAM/CGRAM).	53μs	38μs	29μs

Note1: "-": don't care

Note2: In the operation condition under -20°C ~ 75°C, the maximum execution time for majority of instruction sets is 100μs, except two instructions, "Clear Display" and "Return Home", in which maximum execution time can take up to 4.1ms.



12. Font Characteristic

Upper 4 bit Lower 4 bit	EEEE	EEEH	EEED	EEEH	EHLH	EHLH	EHLH	EHHH	HELL	HELLH	HELH	HEHH	HEHL	HEHLH	HEHHL	HEHHH
EEEE				0	1	2	3	4								
EEEH				5	6	7	8	9								
EEED				A	B	C	D	E								
EEEH				F	G	H	I	J								
EHLH				K	L	M	N	O								
EHLH				P	Q	R	S	T								
EHLH				U	V	W	X	Y								
EHHH				Z	[]	^	_								
HELL				`	a	b	c	d								
HELLH				e	f	g	h	i								
HELH				j	k	l	m	n								
HEHH				o	p	q	r	s								
HEHL				t	u	v	w	x								
HEHLH				y	z	{	}	~								
HEHHL																
HEHHH																



13.QUALITY SPECIFICATIONS

13.1 Standard of the product appearance test

Manner of appearance test: The inspection should be performed in using 20W x 2 fluorescent lamps. Distance between LCM and fluorescent lamps should be 100 cm or more. Distance between LCM and inspector eyes should be 30 cm or more.

Viewing direction for inspection is 45° from vertical against LCM.

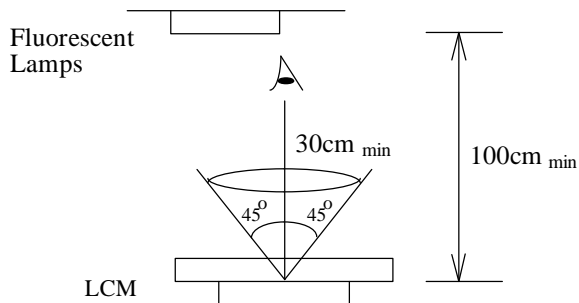

Definition of zone:

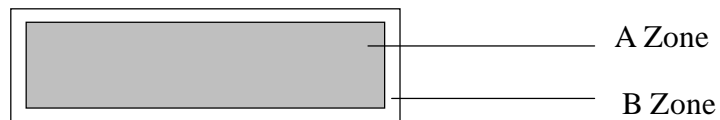

A Zone: Active display area (minimum viewing area).

B Zone: Non-active display area (outside viewing area).

13.2 Specification of quality assurance

AQL inspection standard

Sampling method: MIL-STD-105E, Level II, single sampling



Defect classification (Note: * is not including)

Classify	Item		Note	AQL
Major	Display state	Short or open circuit	1	0.65
		LC leakage		
		Flickering		
		No display		
		Wrong viewing direction		
		Contrast defect (dim, ghost)	2	
		Back-light	1,8	
	Non-display	Flat cable or pin reverse	10	
Wrong or missing component		11		
Minor	Display state	Background color deviation	2	1.0
		Black spot and dust	3	
		Line defect, Scratch	4	
		Rainbow	5	
		Chip	6	
		Pin hole	7	
	Polarizer	Protruded	12	
		Bubble and foreign material	3	
	Soldering	Poor connection	9	
	Wire	Poor connection	10	
	TAB	Position, Bonding strength	13	

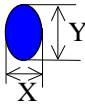
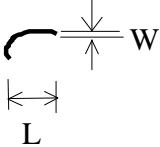

Note on defect classification

No.	Item	Criterion																				
1	Short or open circuit	Not allow																				
	LC leakage																					
	Flickering																					
	No display																					
	Wrong viewing direction																					
	Wrong Back-light																					
2	Contrast defect	Refer to approval sample																				
	Background color deviation																					
3	Point defect, Black spot, dust (including Polarizer) $f = (X+Y)/2$	 <table border="1" data-bbox="919 1025 1343 1312"> <thead> <tr> <th>Point Size</th> <th>Acceptable Qty.</th> </tr> </thead> <tbody> <tr> <td>$f \leq 0.10$</td> <td>Disregard</td> </tr> <tr> <td>$0.10 < f \leq 0.20$</td> <td>3</td> </tr> <tr> <td>$0.20 < f \leq 0.25$</td> <td>2</td> </tr> <tr> <td>$0.25 < f \leq 0.30$</td> <td>1</td> </tr> <tr> <td>$f > 0.30$</td> <td>0</td> </tr> </tbody> </table> <p>Unit: mm</p>	Point Size	Acceptable Qty.	$f \leq 0.10$	Disregard	$0.10 < f \leq 0.20$	3	$0.20 < f \leq 0.25$	2	$0.25 < f \leq 0.30$	1	$f > 0.30$	0								
Point Size	Acceptable Qty.																					
$f \leq 0.10$	Disregard																					
$0.10 < f \leq 0.20$	3																					
$0.20 < f \leq 0.25$	2																					
$0.25 < f \leq 0.30$	1																					
$f > 0.30$	0																					
4	Line defect, Scratch	 <table border="1" data-bbox="850 1485 1383 1738"> <thead> <tr> <th colspan="2">Line</th> <th>Acceptable Qty.</th> </tr> <tr> <th>L</th> <th>W</th> <th></th> </tr> </thead> <tbody> <tr> <td>---</td> <td>$0.015 \geq W$</td> <td>Disregard</td> </tr> <tr> <td>$3.0 \geq L$</td> <td>$0.03 \geq W$</td> <td rowspan="2">2</td> </tr> <tr> <td>$2.0 \geq L$</td> <td>$0.05 \geq W$</td> </tr> <tr> <td>$1.0 \geq L$</td> <td>$0.1 > W$</td> <td>1</td> </tr> <tr> <td>--</td> <td>$0.05 < W$</td> <td>Applied as point defect</td> </tr> </tbody> </table> <p>Unit: mm</p>	Line		Acceptable Qty.	L	W		---	$0.015 \geq W$	Disregard	$3.0 \geq L$	$0.03 \geq W$	2	$2.0 \geq L$	$0.05 \geq W$	$1.0 \geq L$	$0.1 > W$	1	--	$0.05 < W$	Applied as point defect
Line		Acceptable Qty.																				
L	W																					
---	$0.015 \geq W$	Disregard																				
$3.0 \geq L$	$0.03 \geq W$	2																				
$2.0 \geq L$	$0.05 \geq W$																					
$1.0 \geq L$	$0.1 > W$	1																				
--	$0.05 < W$	Applied as point defect																				
5	Rainbow	Not more than two color changes across the viewing area.																				

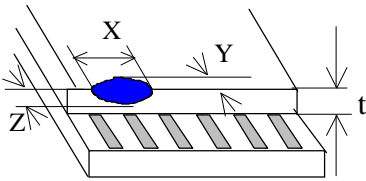
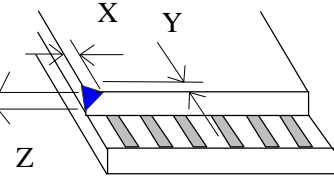
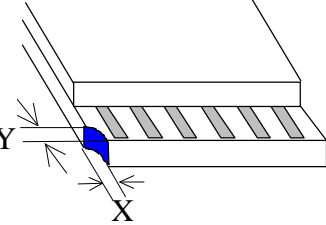
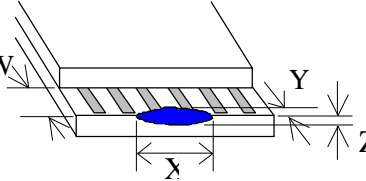
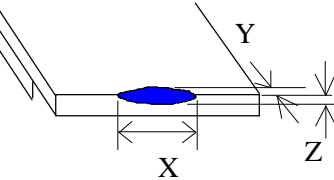

No	Item	Criterion							
6	Chip Remark: X: Length direction Y: Short direction Z: Thickness direction t: Glass thickness W: Terminal Width	 <p>Acceptable criterion</p> <table border="1"> <thead> <tr> <th>X</th> <th>Y</th> <th>Z</th> </tr> </thead> <tbody> <tr> <td>≤ 2</td> <td>0.5mm</td> <td>$\leq t/2$</td> </tr> </tbody> </table>	X	Y	Z	≤ 2	0.5mm	$\leq t/2$	
		X	Y	Z					
		≤ 2	0.5mm	$\leq t/2$					
		 <p>Acceptable criterion</p> <table border="1"> <thead> <tr> <th>X</th> <th>Y</th> <th>Z</th> </tr> </thead> <tbody> <tr> <td>≤ 2</td> <td>0.5mm</td> <td>$\leq t$</td> </tr> </tbody> </table>	X	Y	Z	≤ 2	0.5mm	$\leq t$	
		X	Y	Z					
≤ 2	0.5mm	$\leq t$							
 <p>Acceptable criterion</p> <table border="1"> <thead> <tr> <th>X</th> <th>Y</th> <th>Z</th> </tr> </thead> <tbody> <tr> <td>≤ 3</td> <td>≤ 2</td> <td>$\leq t$</td> </tr> <tr> <td colspan="2">shall not reach to ITO</td> <td></td> </tr> </tbody> </table>	X	Y	Z	≤ 3	≤ 2	$\leq t$	shall not reach to ITO		
X	Y	Z							
≤ 3	≤ 2	$\leq t$							
shall not reach to ITO									
 <p>Acceptable criterion</p> <table border="1"> <thead> <tr> <th>X</th> <th>Y</th> <th>Z</th> </tr> </thead> <tbody> <tr> <td>Disregard</td> <td>≤ 0.2</td> <td>$\leq t$</td> </tr> </tbody> </table>	X	Y	Z	Disregard	≤ 0.2	$\leq t$			
X	Y	Z							
Disregard	≤ 0.2	$\leq t$							
 <p>Acceptable criterion</p> <table border="1"> <thead> <tr> <th>X</th> <th>Y</th> <th>Z</th> </tr> </thead> <tbody> <tr> <td>≤ 5</td> <td>≤ 2</td> <td>$\leq t/3$</td> </tr> </tbody> </table>	X	Y	Z	≤ 5	≤ 2	$\leq t/3$			
X	Y	Z							
≤ 5	≤ 2	$\leq t/3$							

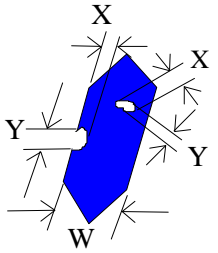
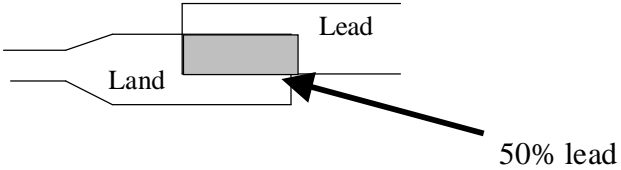

No.	Item	Criterion								
7	Segment pattern W = Segment width $f = (X+Y)/2$	<p>(1) Pin hole $f < 0.10\text{mm}$ is acceptable.</p>  <table border="1" data-bbox="911 685 1359 891"> <thead> <tr> <th>Point Size</th> <th>Acceptable Qty</th> </tr> </thead> <tbody> <tr> <td>$f \leq 1/4W$</td> <td>Disregard</td> </tr> <tr> <td>$1/4W < f \leq 1/2W$</td> <td>1</td> </tr> <tr> <td>$f > 1/2W$</td> <td>0</td> </tr> </tbody> </table>	Point Size	Acceptable Qty	$f \leq 1/4W$	Disregard	$1/4W < f \leq 1/2W$	1	$f > 1/2W$	0
Point Size	Acceptable Qty									
$f \leq 1/4W$	Disregard									
$1/4W < f \leq 1/2W$	1									
$f > 1/2W$	0									
8	Back-light	<p>(1) The color of backlight should correspond its specification. (2) Not allow flickering</p>								
9	Soldering	<p>(1) Not allow heavy dirty and solder ball on PCB. (The size of dirty refer to point and dust defect) (2) Over 50% of lead should be soldered on Land.</p> 								
10	Wire	<p>(1) Copper wire should not be rusted (2) Not allow crack on copper wire connection. (3) Not allow reversing the position of the flat cable. (4) Not allow exposed copper wire inside the flat cable.</p>								
11*	PCB	<p>(1) Not allow screw rust or damage. (2) Not allow missing or wrong putting of component.</p>								

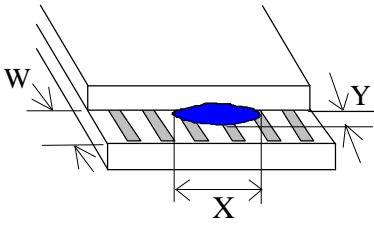
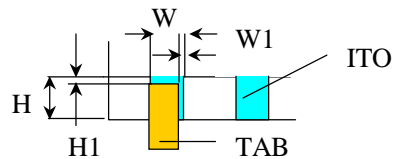
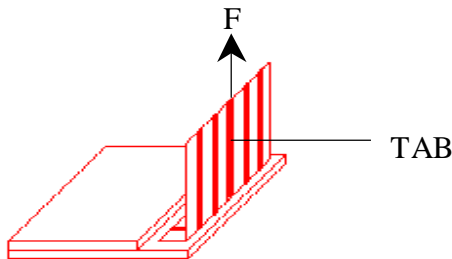

No	Item	Criterion
12	Protruded W: Terminal Width	 <p>Acceptable criteria: $Y \leq 0.4$</p>
13	TAB	<p>1. Position</p>  <div style="border: 1px solid black; padding: 5px; width: fit-content; margin-left: auto; margin-right: auto;"> $W1 \leq 1/3W$ $H1 \leq 1/3H$ </div> <p>2. TAB bonding strength test</p>  <p>$P (=F/TAB \text{ bonding width}) \geq 650gf/cm$,(speed rate: 1mm/min) 5pcs per SOA (shipment)</p>
14	Total no. of acceptable Defect	<p>A. Zone</p> <p>Maximum 2 minor non-conformities per one unit. Defect distance: each point to be separated over 10mm</p> <p>B. Zone</p> <p>It is acceptable when it is no trouble for quality and assembly in customer's end product.</p>



13.3 Reliability of LCM

Reliability test condition:

Item	Condition	Time (hrs)	Assessment
High temp. Storage	80°C	48	No abnormalities in functions and appearance
High temp. Operating	70°C	48	
Low temp. Storage	-30°C	48	
Low temp. Operating	-20°C	48	
Humidity	40°C / 90%RH	48	
Temp. Cycle	-20°C ~ 25°C ~70°C (30 min ~ 5 min ~ 30min)	10cycles	

Recovery time should be 24 hours minimum. Moreover, functions, performance and appearance shall be free from remarkable deterioration within 50,000 hours under ordinary operating and storage conditions room temperature ($20\pm 8^{\circ}\text{C}$), normal humidity (below 65% RH), and in the area not exposed to direct sun light.

13.4 Precaution for using LCD/LCM

LCD/LCM is assembled and adjusted with a high degree of precision. Do not attempt to make any alteration or modification. The followings should be noted.

General Precautions:

1. LCD panel is made of glass. Avoid excessive mechanical shock or applying strong pressure onto the surface of display area.
2. The polarizer used on the display surface is easily scratched and damaged. Extreme care should be taken when handling. To clean dust or dirt off the display surface, wipe gently with cotton, or other soft material soaked with isopropyl alcohol, ethyl alcohol or trichlorotrifluoroethane, do not use water, ketone or aromatics and never scrub hard.
3. Do not tamper in any way with the tabs on the metal frame.
4. Do not made any modification on the PCB without consulting AV.
5. When mounting a LCM, make sure that the PCB is not under any stress such as bending or twisting. Elastomer contacts are very delicate and missing pixels could result from slight dislocation of any of the elements.
6. Avoid pressing on the metal bezel, otherwise the elastomer connector could be deformed and lose contact, resulting in missing pixels and also cause rainbow on the display.



深圳秋田微电子有限公司
SHENZHEN AV-DISPLAY CO.,LTD.

7. Be careful not to touch or swallow liquid crystal that might leak from a damaged cell. Any liquid crystal adheres to skin or clothes, wash it off immediately with soap and water.

Static Electricity Precautions:

1. CMOS-LSI is used for the module circuit; therefore operators should be grounded whenever he/she comes into contact with the module.
2. Do not touch any of the conductive parts such as the LSI pads; the copper leads on the PCB and the interface terminals with any parts of the human body.
3. Do not touch the connection terminals of the display with bare hand; it will cause disconnection or defective insulation of terminals.
4. The modules should be kept in anti-static bags or other containers resistant to static for storage.
5. Only properly grounded soldering irons should be used.
6. If an electric screwdriver is used, it should be grounded and shielded to prevent sparks.
7. The normal static prevention measures should be observed for work clothes and working benches.
8. Since dry air is inductive to static, a relative humidity of 50-60% is recommended.

Soldering Precautions:

1. Soldering should be performed only on the I/O terminals.
2. Use soldering irons with proper grounding and no leakage.
3. Soldering temperature: $280^{\circ}\text{C} \pm 10^{\circ}\text{C}$
4. Soldering time: 3 to 4 second.
5. Use eutectic solder with resin flux filling.
6. If flux is used, the LCD surface should be protected to avoid spattering flux.
7. Flux residue should be removed.

Operation Precautions:

1. The viewing angle can be adjusted by varying the LCD driving voltage V_o .
2. Since applied DC voltage causes electro-chemical reactions, which deteriorate the display, the applied pulse waveform should be a symmetric waveform such that no DC component remains. Be sure to use the specified operating voltage.
3. Driving voltage should be kept within specified range; excess voltage will shorten display life.
4. Response time increases with decrease in temperature.
5. Display color may be affected at temperatures above its operational range.
6. Keep the temperature within the specified range usage and storage. Excessive temperature and humidity could cause polarization degradation, polarizer peel-off or generate bubbles.
7. For long-term storage over 40°C is required, the relative humidity should be kept below 60%, and avoid direct sunlight.



深圳秋田微电子有限公司
SHENZHEN AV-DISPLAY CO.,LTD.

Limited Warranty

AV LCDs and modules are not consumer products, but may be incorporated by AV's customers into consumer products or components thereof, AV does not warrant that its LCDs and components are fit for any such particular purpose.

1. The liability of AV is limited to repair or replacement on the terms set forth below. AV will not be responsible for any subsequent or consequential events or injury or damage to any personnel or user including third party personnel and/or user. Unless otherwise agreed in writing between AV and the customer, AV will only replace or repair any of its LCD which is found defective electrically or visually when inspected in accordance with AV general LCD inspection standard . (Copies available on request)
2. No warranty can be granted if any of the precautions state in handling liquid crystal display above has been disregarded. Broken glass, scratches on polarizer mechanical damages as well as defects that are caused accelerated environment tests are excluded from warranty.
3. In returning the LCD/LCM, they must be properly packaged; there should be detailed description of the failures or defect.