

REV	ECN NO.	DESCRIPTION	DATE
A		RELEASE	NOV.11'04

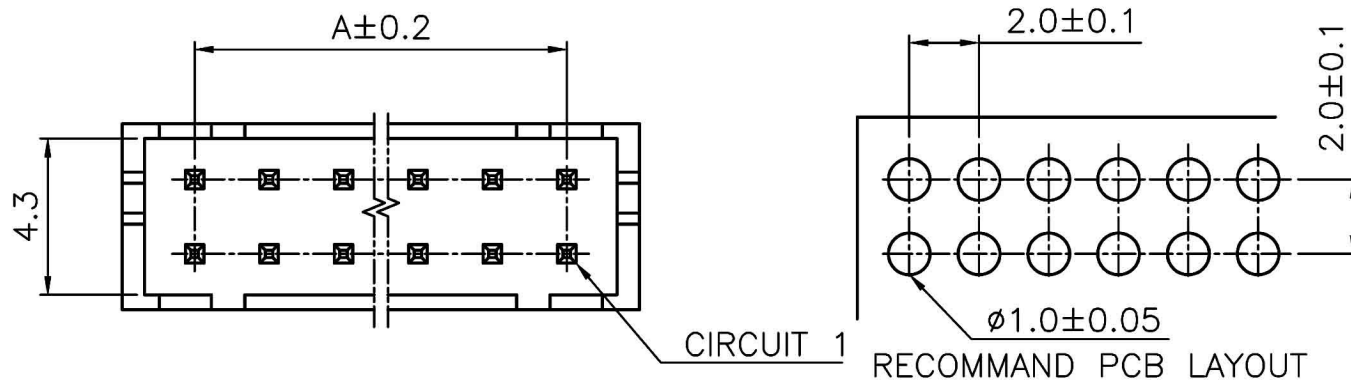

■ SPECIFICATIONS

- Voltage Rating : 250V AC/DC
- Current Rating : 3A AC/DC
- Withstanding Voltage : 800V AC/minute
- Insulation Resistance : 1,000MΩ min
- Temperature Range : - 25°C to + 85°C
- Contact Resistance : 20mΩ max

■ WAFER

- Part No. : 2008 (Stright)
- Poles : 3x2 - 16x2
- Material : Contact : Brass, Tin Plated  
Base : Nylon 66 UL94V-0
- Q' ty : 1,000 pcs.Bag

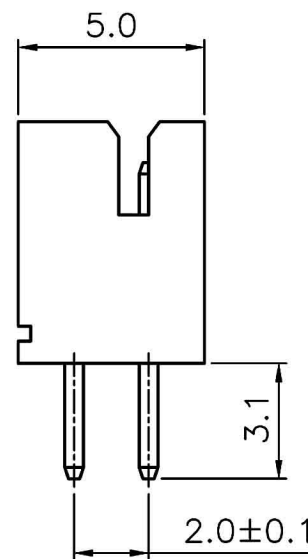
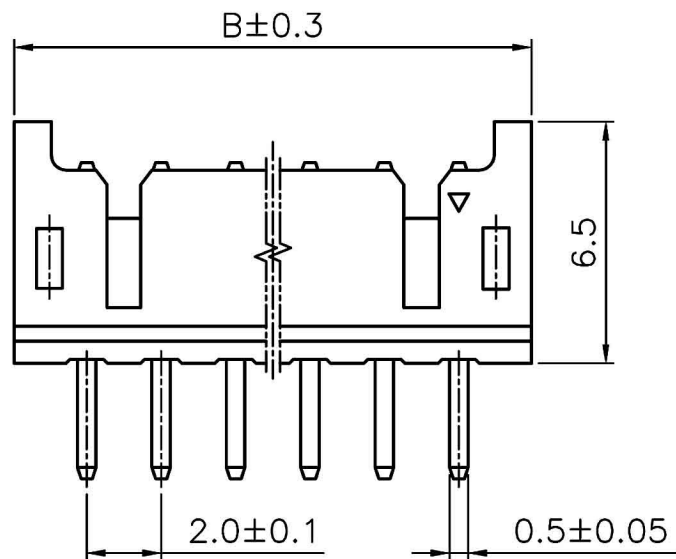

Poles	Part No.	Dimensions(mm)	
		A	B
3	200806ST (/SN)	4.00	7.90
4	200808ST (/SN)	6.00	9.90
5	200810ST (/SN)	8.00	11.90
6	200812ST (/SN)	10.00	13.90
7	200814ST (/SN)	12.00	15.90
8	200816ST (/SN)	14.00	17.90
9	200818ST (/SN)	16.00	19.90
10	200820ST (/SN)	18.00	21.90
11	200822ST (/SN)	20.00	23.90
12	200824ST (/SN)	22.00	25.90
13	200826ST (/SN)	24.00	27.90
14	200828ST (/SN)	26.00	29.90
15	200830ST (/SN)	28.00	31.90
16	200832ST (/SN)	30.00	33.90

TOLERANCE UNLESS OTHERWISE SPECIFIED		
LINEAR	ANGLE	
X. ±	X° ±	
.X ± 0.30	.X° ±	
.XX ± 0.20	.XX° ±	
.XXX ±	.XXX° ±	
APPD		
CHKD		
DRAW	Z	NOV. 11' 04

PROJECTION	
UNITS	MM
SCALE	
SIZE	A4



GOLD-TEK ELECTRIC CO., LTD.

TITLE  
2.00MM PITCH WAFER  
STRIGHT TYPE  
CPART NO.

PART NO.  
2008\*\*ST (/SN)

CAD NO. 1056  
F:\DRW\HW-A\HW-A0037  
SHEET  
1 OF 1

圖面編號:GTKSD1334-A(1)