



TAIWAN OASIS LED DATA SHEET

PART NO. : TOS-5161AE-B

APPEARANCE			TECHNOLOGIE	GaAsP/GaP
FACE	SEGMENT	PIN	SOURCE COLOR	Orange
Black	White	∅0.51x10.28	DRIVER MODE	Com. Cathode
			PACKING	"ML" Plastic Box

PACKAGE DIMENSIONS

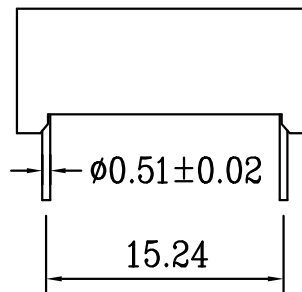
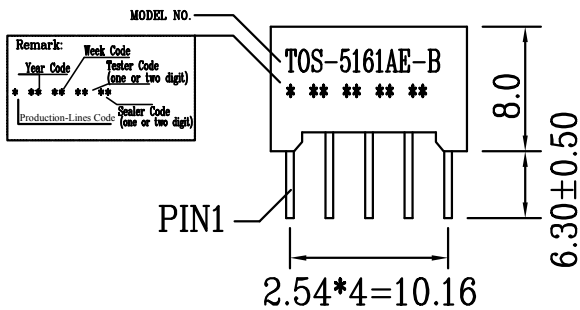
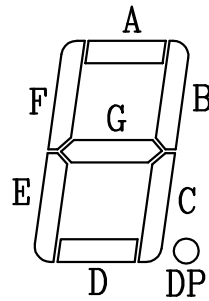
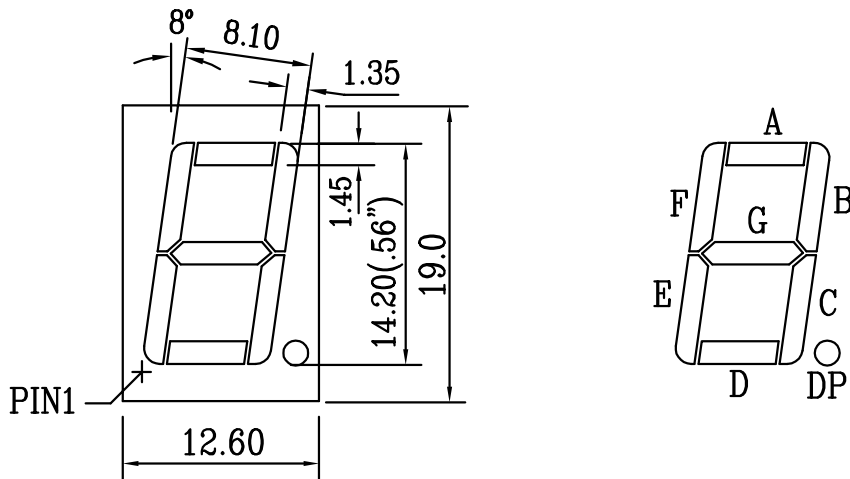

NORMAL TOLERANCE: ±0.25 ANGLE: ±1°

INTERNAL CIRCUIT DIAGRAM

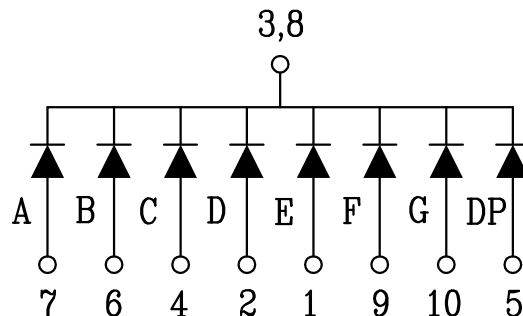

DATE	07/09/07'	SCALE	2:1	DRAWING NO.	S-5161AE-B-A	DRAWN	W.F.H	CHECKED	
UNIT	M/M	SHEET NO.	1/2			CUSTOMER	ES017	APPROVED	



TAIWAN OASIS LED SPECIFICATION

PART NO. : TOS-5161AE-B

ABSOLUTE MAXIMUM RATINGS AT TA=25°C

PARAMETER	VALUE	UNITS
Power Dissipation Per Segment	75	mW
Peak Forward Current Per Segment (1/10 Duty Cycle, 0.1ms Pulse Width)	80	mA
Continuous Forward Current Per Segment	20	mA
Recommend Operating Current	12	mA
Reverse Voltage Per Segment	5	V
Operating Temperature Range	-25 to +85	°C
Storage Temperature Range	-30 to +85	°C
Junction Temperature	>85	°C
Lead Free Solder Temperature(1/16 Inch Below Seating Plane)	260°C for 3 sec.	

ELECTRICAL/OPTICAL CHARACTERISTICS AT TA=25°C

PARAMETER	SYMBOL	MIN.	TYP.	MAX.	UNITS	TEST CONDITION
Luminous Intensity Per Segment	I _v	2501	4133		μcd	I _F = 10mA
Peak Emission Wavelength	λ _p		630		nm	I _F = 20mA
Spectral Line Half-Width	Δλ		35		nm	I _F = 20mA
Forward Voltage Per Segment	V _F	1.8	2.1	2.4	V	I _F = 20mA
Reverse Current Per Segment	I _R			20	μA	V _R = 5V
Luminous Intensity Matching Rate	I _v -m			1.5:1		I _F = 20mA

DATE	07/09/07'	SCALE	———	DRAWING NO.	S-5161AE-B-A	DRAWN	W.F.H	CHECKED	
UNIT	———	SHEET NO.	2/2			CUSTOMER	ES017	APPROVED	