



Innovative Technology

INTELLIGENCE IN VALIDATION

SMART Coin System

*“Bulk coin feeder,
hopper and recycler”*



- State of the art bulk coin validator, hopper & recycler
- Lowest cost of ownership
- Eliminates coin starvation
- Market leading coin capacity, acceptance & payout speed
- High security - multi frequency sensing technology



FEATURES

- Combined bulk coin validator, mixed coin hopper & recycler
- Market leading coin hopper capacity, fully audited and efficient refills
- Validates, discriminates and stores mixed coins
- Minimise distance between coin entry and exit points
- Easy maintenance, free firmware updates and data logging
- Closed loop system



BENEFITS

- Eliminates coin starvation & the need for multiple hoppers
- Reduces operator collection costs
- Improve operator cashflow with mixed denomination payouts - keep machines running
- Allows for space saving new machine design
- Future proof (easy updates via USB, SD card, PC)
- Full audit traceability - no shrinkage

Technical Specification

Power

Requirements: 24V
Standby: 200mA
Running: 3A
Peak: 6.5A

Protocols

SSP
ccTalk

Interfaces

USB option
Open collector

Coin Dimensions

Diameter: 18 - 28.5mm
Thickness: 1.65 - 3.2mm

Coin Capacity

1500 (€1) or 1300 (€1) or 800 (€2)

Multiple Denomination

Up to 11 denominations

Mixed Coin Capacity

200 (€2) + 750 (€1) + 500 (50c)

Payout Speed

Up to 12 coins per second

MCBF

100,000

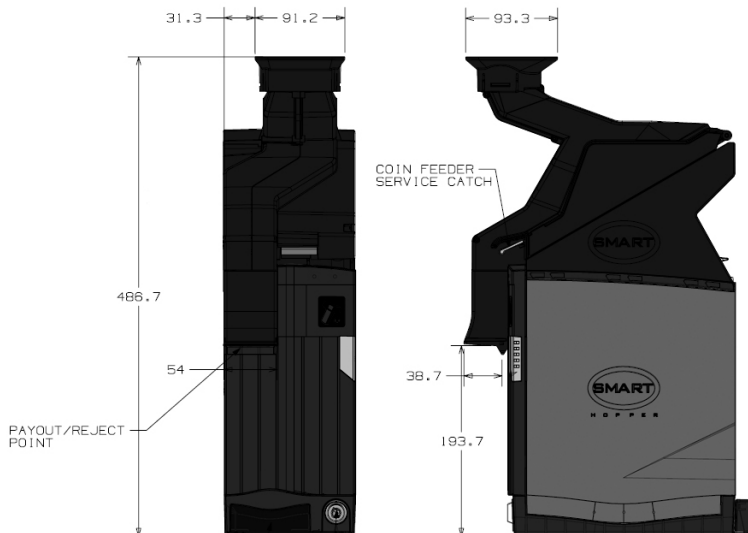

- Weight: 4.1kg (empty) | 15.4kg (full)

**VIEW MORE
COIN HANDLING
PRODUCTS >>**



Find Us

Head Office

Innovative Technology Ltd (UK)
Innovative Business Park
Derker Street
Oldham
OL1 4EQ



Telephone

+44 (0) 161 626 9999



Email

sales@innovative-technology.com