



PRODUCT SPECIFICATION

MICRO SIM CONNECTOR, HINGE TYPE, 1.60MM MAX HEIGHT

1.0 SCOPE

This Product Specification covers the performance requirements of the SIM Card Connector (Hinge Type).

2.0 PRODUCT DESCRIPTION

2.1 PRODUCT NAME AND SERIES NUMBER(S)

Product Name

Series Number

MICRO SIM CONNECTOR, HINGE TYPE, 1.60MM MAX HEIGHT

78800

2.2 DIMENSIONS, MATERIALS, PLATINGS AND MARKINGS

See Sales Drawing for information on dimensions, materials, platings and markings.

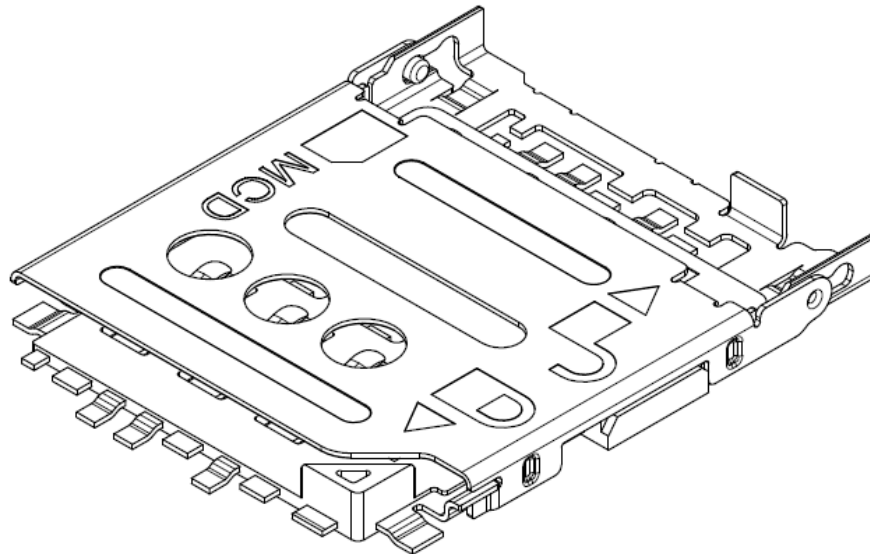

TENTATIVE RELEASE:

THIS SPECIFICATION IS BASED ON DESIGN OBJECTIVES AND IS STRICTLY TENTATIVE. PRELIMINARY TEST DATA MAY EXIST, BUT THIS SPECIFICATION IS SUBJECTED TO CHANGE BASED ON THE RESULTS OF ADDITIONAL TESTING AND EVALUATION.

REVISION: A	ECR/ECN INFORMATION: EC No: S2015-0120 DATE: 2015/08/14	TITLE: MICRO SIM CONNECTOR, HINGE TYPE, 1.60MM MAX HEIGHT	SHEET No. 1 of 14
DOCUMENT NUMBER: PS-78800-001	CREATED / REVISED BY: EANG	CHECKED BY: JTAN	APPROVED BY: KHLIM



PRODUCT SPECIFICATION

3.0 APPLICABLE DOCUMENTS AND SPECIFICATIONS

The following documents form a part of this specification to the extended specified herewith. In the event of conflict between the requirements of this specification and the product drawing, the product drawing shall take precedence.

4.0 RATINGS

4.1 CURRENT RATING

0.5Amps Max. per contact

4.2 VOLTAGE RATING

5 Volt DC Max.

4.3 TEMPERATURE

Operating: - 30°C to + 85°C

5.0 MECHANICAL INTERFACE

5.1 CARD INTERFACE

SIM card interface: GSM 11.11 specification

5.2 PWB INTERFACE

Plating on PWB pads: OSP plated copper

6.0 PERFORMANCE

6.1 ELECTRICAL REQUIREMENTS

ITEM	DESCRIPTION	TEST CONDITION	REQUIREMENT
1	Contacts Low Level Contact Resistance (LLCR)	Mate connectors with dry circuit (20 mV , 100 mA MAX) on mated connector. Refer to appendix 1. (IEC 60512-2-1)	100 mΩ [MAXIMUM] Value includes bulk resistance of terminal
2	Insulation Resistance	Unmated connectors: apply a voltage of 500 VDC between adjacent contact for 1 minutes (IEC 60512-3-1)	1000 MΩ [MINIMUM]

<u>REVISION:</u> A	<u>ECR/ECN INFORMATION:</u> EC No: S2015-0120 DATE: 2015/08/14	<u>TITLE:</u> MICRO SIM CONNECTOR, HINGE TYPE, 1.60MM MAX HEIGHT	<u>SHEET No.</u> 2 of 14
<u>DOCUMENT NUMBER:</u> PS-78800-001	<u>CREATED / REVISED BY:</u> EANG	<u>CHECKED BY:</u> JTAN	<u>APPROVED BY:</u> KHLIM



PRODUCT SPECIFICATION

3	Dielectric Withstanding Voltage	Unmated connectors: apply a voltage of 500 VAC between adjacent contact for 1 minutes (IEC 60512-3-1)	No voltage breakdown
4	Temperature Rise	Mated and measure the temperature rise of contact, when rated current is passed. (IEC 60512-5-1)	Temperature Rise +30°C [MAXIMUM]

6.2 MECHANICAL REQUIREMENTS

ITEM	DESCRIPTION	TEST CONDITION	REQUIREMENT
5	Contact Normal Force	Apply perpendicular force to terminal at the rate of 12.5mm/min. Measure contact normal force at 0.32mm working height, read at return curve. Refer to appendix 2.	0.20 N [MINIMUM] 1.30 N REF. [MAXIMUM]
6	Lock/unlock force	Lock and unlock shell from housing at a rate of 25mm/min. Lock and unlock 3 times before taking initial reading.	Unlocking/Locking force 15N (WITH CARD)
7	Durability (Terminal)	Mate and unmate connector at vertical direction to maximum deflection case for <ul style="list-style-type: none"> • 5000cycles • At a rate of 500~600cycles/hour Take LLCR and normal force readings at 5000 th cycles. Refer to appendix 1 and 2. (EIA-364-09)	Contact Normal Force 0.20N [MINIMUM] LLCR 100 mΩ. [MAXIMUM]

<u>REVISION:</u> A	<u>ECR/ECN INFORMATION:</u> EC No: S2015-0120 DATE: 2015/08/14	<u>TITLE:</u> MICRO SIM CONNECTOR, HINGE TYPE, 1.60MM MAX HEIGHT	<u>SHEET No.</u> 3 of 14
<u>DOCUMENT NUMBER:</u> PS-78800-001	<u>CREATED / REVISED BY:</u> EANG	<u>CHECKED BY:</u> JTAN	<u>APPROVED BY:</u> KHLIM



PRODUCT SPECIFICATION

8	Durability (Locking system)	Mate and unmate connector to 500cycles. Take reading at 500 th cycles. 1cycle (card loaded) = shell closed → shell locked → shell unlocked → shell opened.	Unlocking/locking force 1.0 N (With Card) [MINIMUM] Contacts contact resistance 100 mΩ [MAXIMUM] No mechanical damage
9	Vibration (Random)	Frequency: 10~100 Hz, 0.0132 g ² /Hz; Frequency: 100~500Hz, -3dB/Oct Applied for 1 hour in each 3 mutually perpendicular axes (IEC60068-2-64 Fh)	Contact resistance 100 mΩ [MAXIMUM] Discontinuity < 1 μs
10	Mechanical Shock (specified pulse)	Pulse shape = half sine Peak acceleration = 490m/s ² (50G) Duration of pulse = 11ms Apply 3 successive shocks in each direction along the 3 mutually perpendicular axes. (IEC-60068-2-27 EA)	Contact resistance 100 mΩ [MAXIMUM] Meet Contact Force Spec Discontinuity < 1 μs

<u>REVISION:</u> A	<u>ECR/ECN INFORMATION:</u> EC No: S2015-0120 DATE: 2015/08/14	<u>TITLE:</u> MICRO SIM CONNECTOR, HINGE TYPE, 1.60MM MAX HEIGHT	<u>SHEET No.</u> 4 of 14
<u>DOCUMENT NUMBER:</u> PS-78800-001	<u>CREATED / REVISED BY:</u> EANG	<u>CHECKED BY:</u> JTAN	<u>APPROVED BY:</u> KHLIM



PRODUCT SPECIFICATION

6.3 ENVIRONMENTAL REQUIREMENTS

ITEM	DESCRIPTION	TEST CONDITION	REQUIREMENT
11	High Temperature Storage Life	At +85°C for 96 hours Recovery: 2 hours at ambient atmosphere (IEC60068-2-2 Bb)	Contacts contact resistance 100 mΩ [MAXIMUM] No mechanical damage, corrosion and oxidation at contact area
12	Thermal Shock	25 cycle at Ta = -55°C for 0.5 hours, then change of temp = 25°C MAX 5min, then, Tb = +85°C for 0.5hour, then cool to ambient Recovery: 2hours at ambient atmosphere (IEC60068-2-14 Na)	Contacts contact resistance 100 mΩ [MAXIMUM] No mechanical damage, corrosion and oxidation at contact area
13	Damp Heat (Cyclic)	Temp 25-55°C and 90-100%RH for 18 cycles of 24hours. Recovery at 25°C and 25~75%RH for 2hours. (Typical cycle in temp 25°C → 55°C in 3 hours; then maintain at 55°C for 9hours) (IEC60068-2-30Db)	Contacts contact resistance 100 mΩ [MAXIMUM] Insulation resistance 1000 MΩ [MINIMUM] No voltage breakdown No mechanical damage, corrosion and oxidation at contact area
14	Solderability	Solder paste is deposited on a ceramic plate via stencil. The connectors are steam aged and placed onto the solder paste print. The substrate is processed through a forced hot convection oven. Refer to section 9.0 for temp profile. The connectors are removed from the ceramic and inspected. Steam Aging: 8 hour (ANSI-J-STD 002)	Solder coverage = 95% [MINIMUM]

<u>REVISION:</u> A	<u>ECR/ECN INFORMATION:</u> EC No: S2015-0120 DATE: 2015/08/14	<u>TITLE:</u> MICRO SIM CONNECTOR, HINGE TYPE, 1.60MM MAX HEIGHT	<u>SHEET No.</u> 5 of 14
<u>DOCUMENT NUMBER:</u> PS-78800-001	<u>CREATED / REVISED BY:</u> EANG	<u>CHECKED BY:</u> JTAN	<u>APPROVED BY:</u> KHLIM



PRODUCT SPECIFICATION

15	Resistance to Soldering Condition	Unmated sample to be passed through reflow over according to temperature profiles shown in section 9.0 Reflow cycle: 3X times	No mechanical damage
-----------	------------------------------------------	--------------------------------------------------------------------------------------------------------------------------------------	----------------------

7.0 PACKAGING

Parts shall be packaged to protect against damage during handling, transit and storage. The parts shall be carried in reels inside boxes. For details, kindly refer to Packaging Specification PK-78800-001 and Sale drawing SD-78800-001.

<u>REVISION:</u> A	<u>ECR/ECN INFORMATION:</u> EC No: S2015-0120 DATE: 2015/08/14	<u>TITLE:</u> MICRO SIM CONNECTOR, HINGE TYPE, 1.60MM MAX HEIGHT	<u>SHEET No.</u> 6 of 14
<u>DOCUMENT NUMBER:</u> PS-78800-001		<u>CREATED / REVISED BY:</u> EANG	<u>CHECKED BY:</u> JTAN
		<u>APPROVED BY:</u> KHLIM	



PRODUCT SPECIFICATION

8.0 TEST SEQUENCES

Test Group →	Full Qualification Test						Screen Test			
	Group 1	Group 2	Group 3	Group 4	Group 5	Group 6	Group 7	Group 8		Group 9
								A	B	
Test or Examination ↓										
Sample size	5	5	5	5	5	5	5	5	5	5
Resistance to Soldering Conditions	1	1	1	1	1	1	1	1	1	
Contact Resistance (LLCR)	2,4,6			2,4,6	2,4	2,4	2,6	2,5		
Insulation Resistance		2,5							2	
Dielectric Withstanding Voltage		3,6							3	
Temperature Rise			2							
Contact Normal Force								3,6		
Durability (Terminal)	3							4		
Durability (Locking system)							4			
Lock/unlock force							3,5			
Vibration (Random)				3						
Mechanical Shock				5						
High Temperature Storage Life					3					
Thermal Shock						3				
Damp Heat	5	4								
Solderability										1

REVISION: A	ECR/ECN INFORMATION: EC No: S2015-0120 DATE: 2015/08/14	TITLE: MICRO SIM CONNECTOR, HINGE TYPE, 1.60MM MAX HEIGHT	SHEET No. 7 of 14
DOCUMENT NUMBER: PS-78800-001	CREATED / REVISED BY: EANG	CHECKED BY: JTAN	APPROVED BY: KHLIM



PRODUCT SPECIFICATION

9.0 SOLDERING PROFILE

Lead-free reflow profile requirement for solderability testing

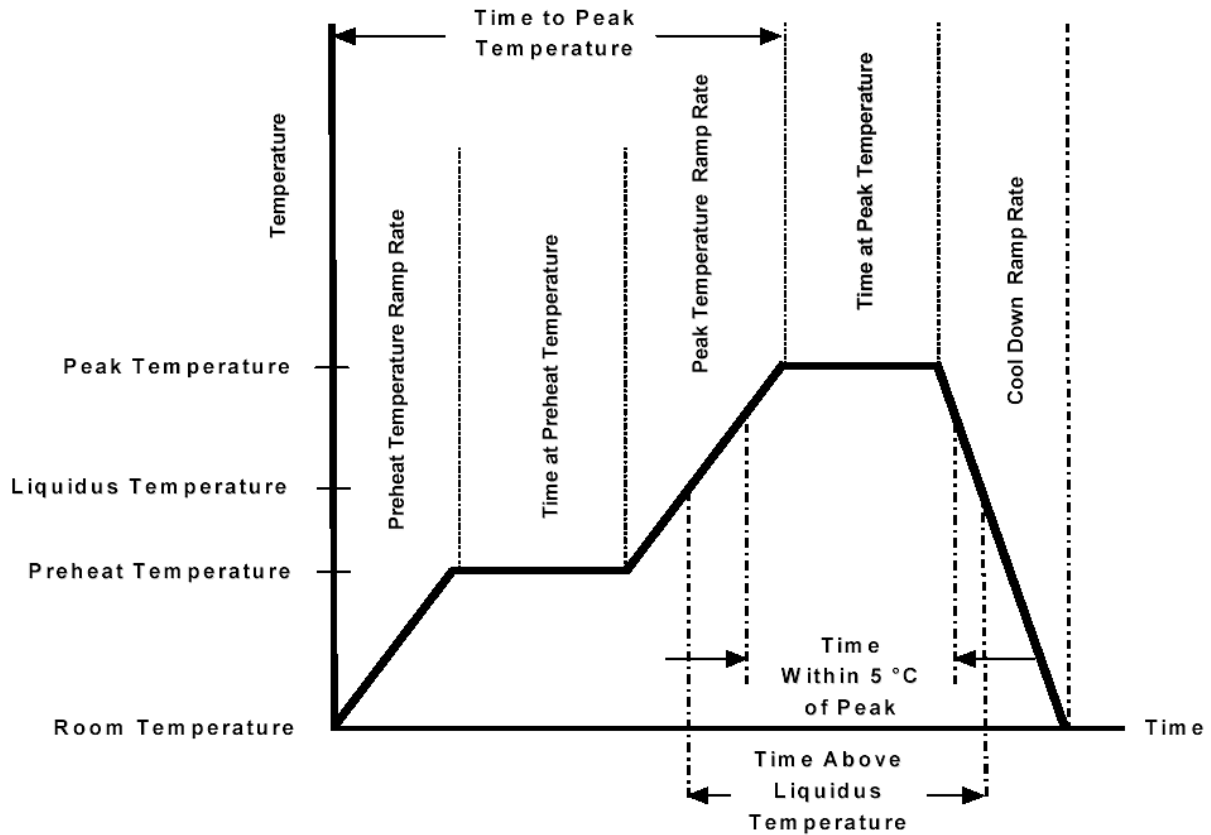

Description	Requirement
Average Ramp Rate	3°C/sec Max
Preheat Temperature	150°C Min to 180°C Max
Preheat Time	60 to 120 sec
Ramp to Peak	3°C/sec Max
Time over Liquidus (217°C)	30 sec Max
Peak Temperature	230 -0/+5°C
Time within 5°C of Peak	10 sec
Ramp - Cool Down	5°C/sec Max

REVISION: A	ECR/ECN INFORMATION: EC No: S2015-0120 DATE: 2015/08/14	TITLE: MICRO SIM CONNECTOR, HINGE TYPE, 1.60MM MAX HEIGHT	SHEET No. 8 of 14
DOCUMENT NUMBER: PS-78800-001	CREATED / REVISED BY: EANG	CHECKED BY: JTAN	APPROVED BY: KHLIM



PRODUCT SPECIFICATION

Lead-free reflow profile requirement for soldering heat resistance testing

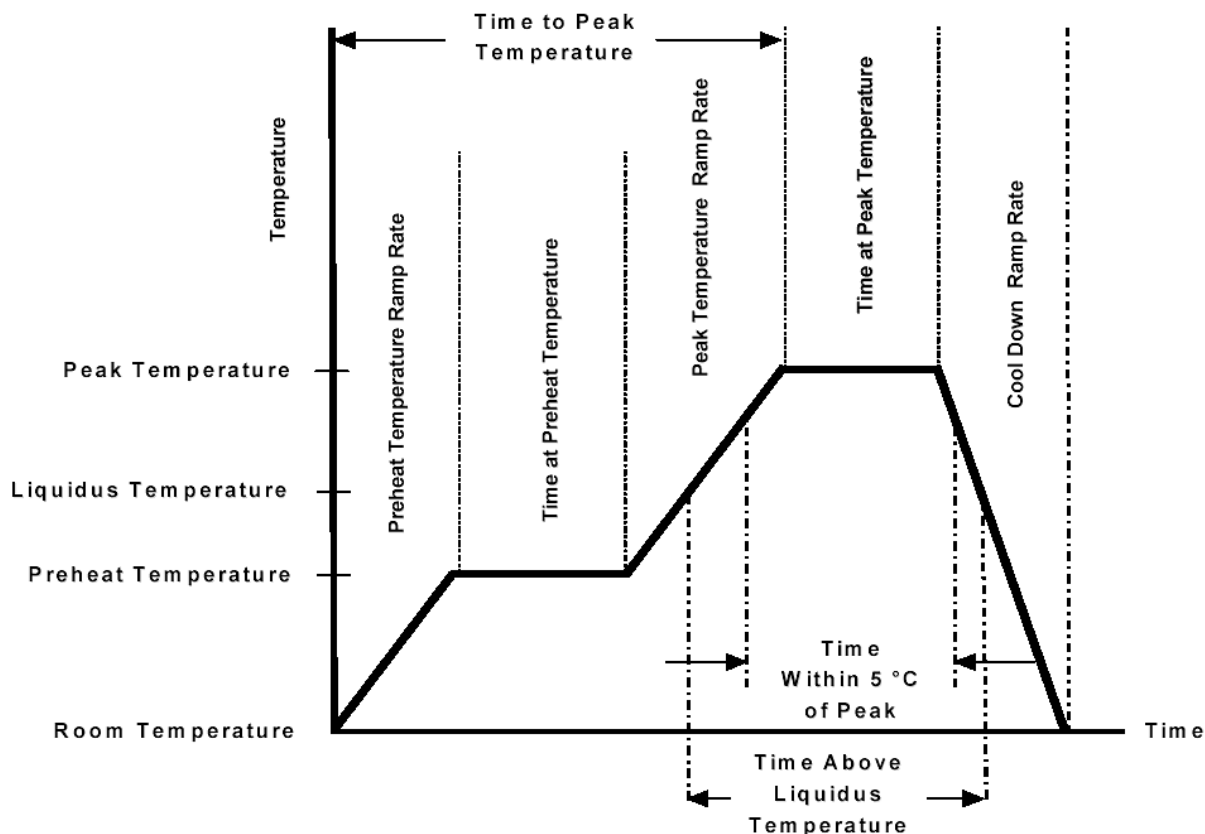

Description	Requirement
Average Ramp Rate	3°C/sec Max
Preheat Temperature	150°C Min to 180°C Max
Preheat Time	120 to 180 sec
Ramp to Peak	3°C/sec Max
Time over Liquidus (217°C)	65 to 150 sec Max
Peak Temperature	255 -0/+5°C
Time within 5°C of Peak	10 sec
Ramp - Cool Down	5°C/sec Max
Time 40°C to 220	3 to 8 Min

REVISION: A	ECR/ECN INFORMATION: EC No: S2015-0120 DATE: 2015/08/14	TITLE: MICRO SIM CONNECTOR, HINGE TYPE, 1.60MM MAX HEIGHT	SHEET No. 9 of 14
DOCUMENT NUMBER: PS-78800-001	CREATED / REVISED BY: EANG	CHECKED BY: JTAN	APPROVED BY: KHLIM



PRODUCT SPECIFICATION

10.0 SIM CARD MOUNTING SEQUENCE

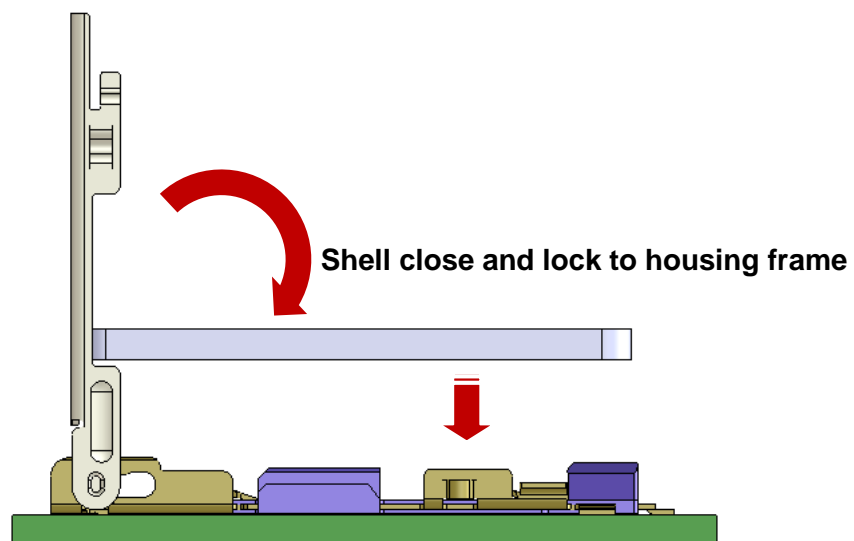
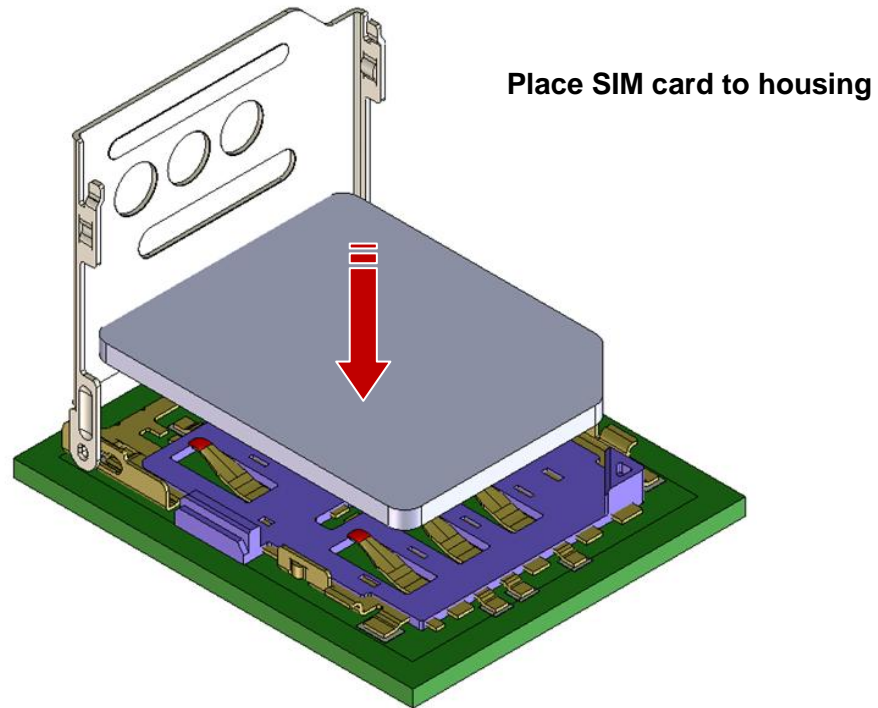

REVISION: A	ECR/ECN INFORMATION: EC No: S2015-0120 DATE: 2015/08/14	TITLE: MICRO SIM CONNECTOR, HINGE TYPE, 1.60MM MAX HEIGHT	SHEET No. 10 of 14
DOCUMENT NUMBER: PS-78800-001	CREATED / REVISED BY: EANG	CHECKED BY: JTAN	APPROVED BY: KHLIM



PRODUCT SPECIFICATION

11.0 CONNECTOR SHELL LOCKING AND UNLOCKING SEQUENCE

A. Locked Position

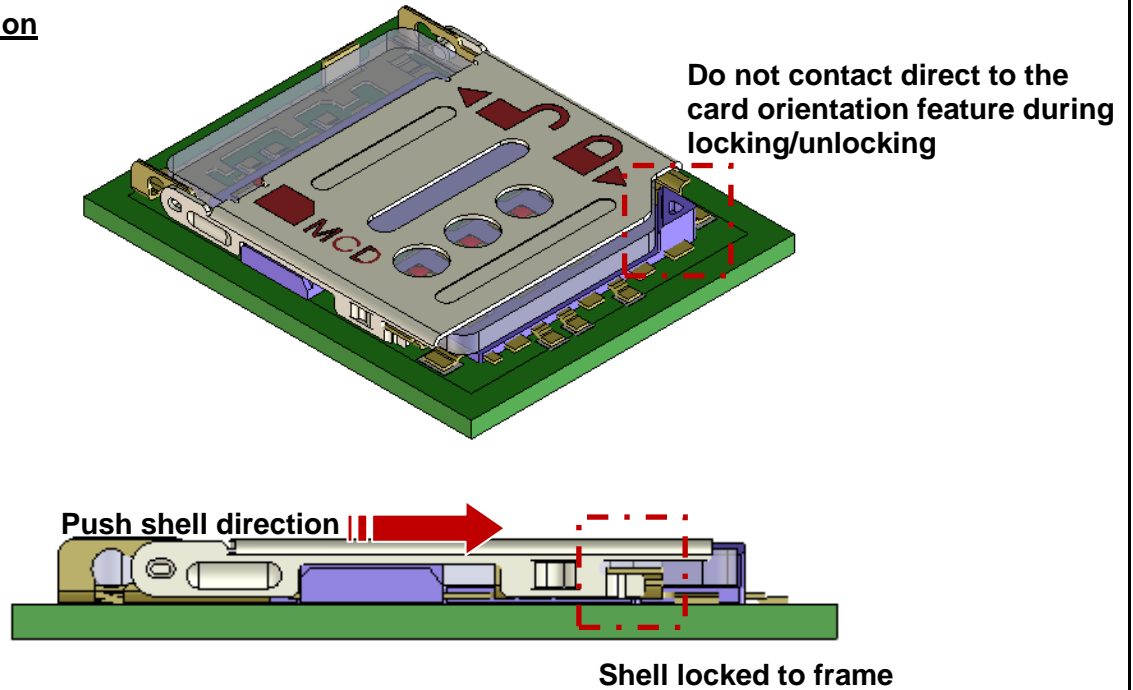

B. Unlocked Position

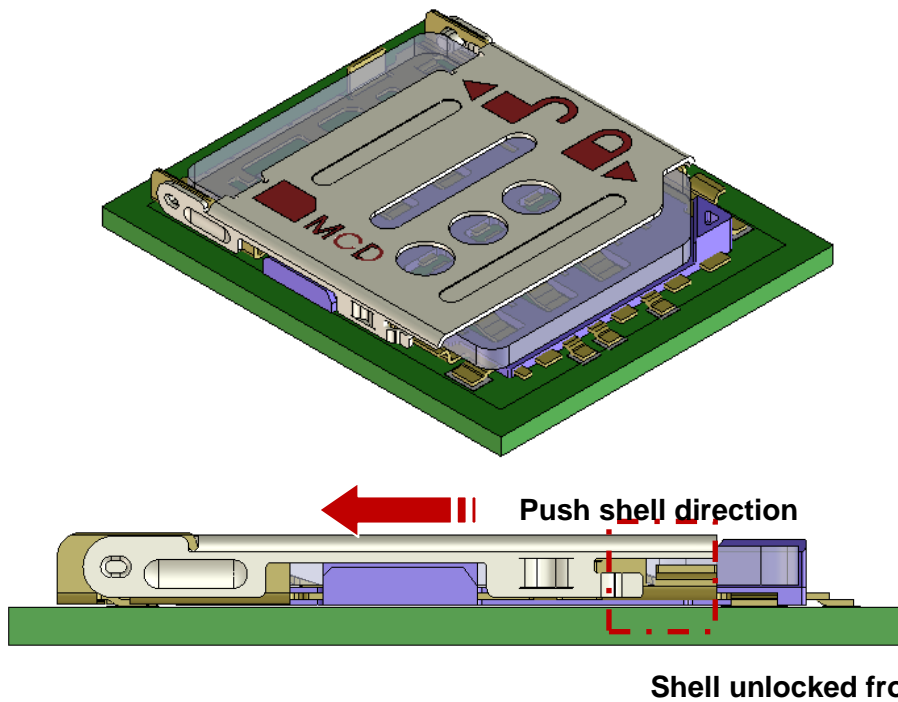

REVISION: A	ECR/ECN INFORMATION: EC No: S2015-0120 DATE: 2015/08/14	TITLE: MICRO SIM CONNECTOR, HINGE TYPE, 1.60MM MAX HEIGHT	SHEET No. 11 of 14
DOCUMENT NUMBER: PS-78800-001	CREATED / REVISED BY: EANG	CHECKED BY: JTAN	APPROVED BY: KHLIM



PRODUCT SPECIFICATION

C. Open at 90 Degree Position

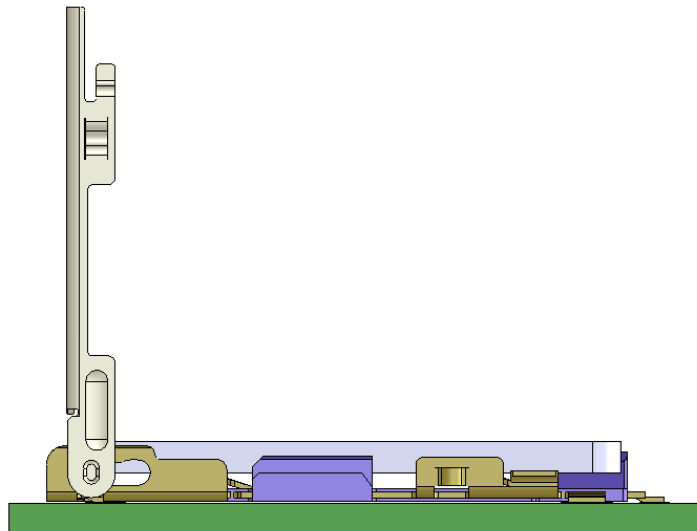
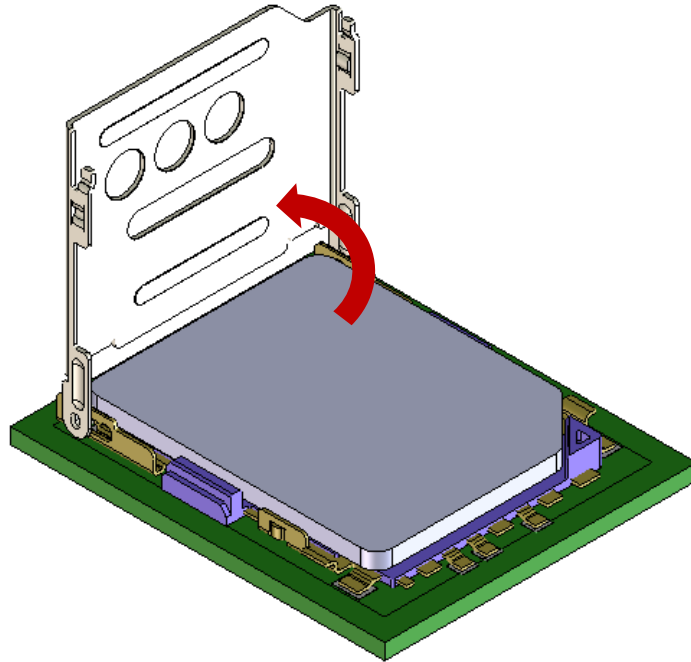

<u>REVISION:</u> A	<u>ECR/ECN INFORMATION:</u> EC No: S2015-0120 DATE: 2015/08/14	<u>TITLE:</u> MICRO SIM CONNECTOR, HINGE TYPE, 1.60MM MAX HEIGHT	<u>SHEET No.</u> 12 of 14
<u>DOCUMENT NUMBER:</u> PS-78800-001	<u>CREATED / REVISED BY:</u> EANG	<u>CHECKED BY:</u> JTAN	<u>APPROVED BY:</u> KHLIM



PRODUCT SPECIFICATION

D. Open at 180 Degree Position

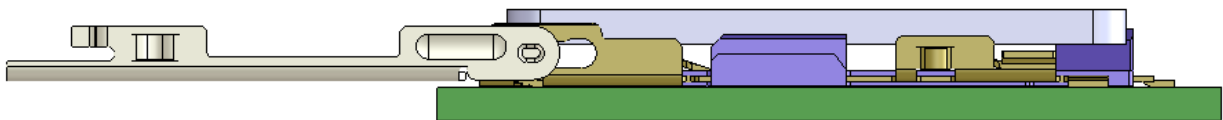
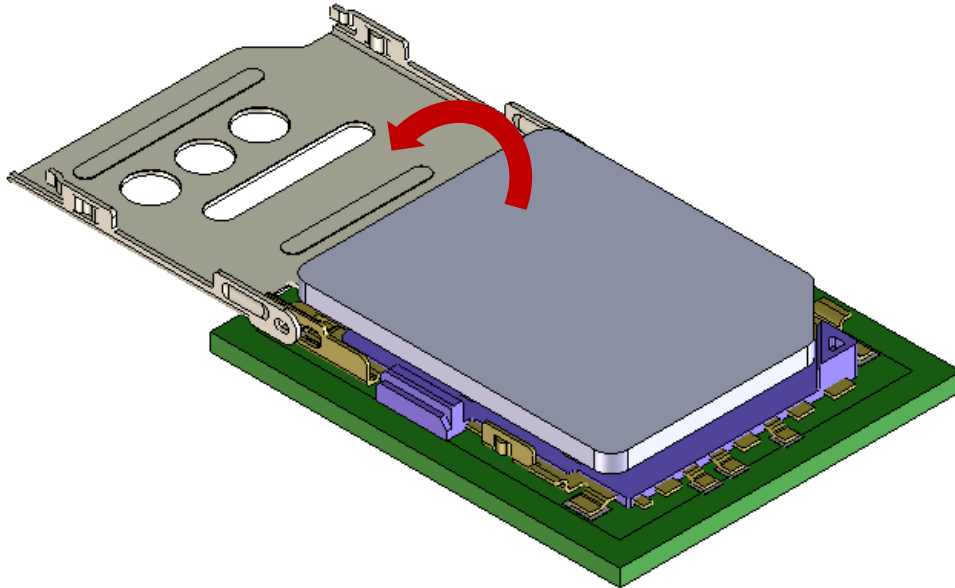

REVISION: A	ECR/ECN INFORMATION: EC No: S2015-0120 DATE: 2015/08/14	TITLE: MICRO SIM CONNECTOR, HINGE TYPE, 1.60MM MAX HEIGHT	SHEET No. 13 of 14
DOCUMENT NUMBER: PS-78800-001	CREATED / REVISED BY: EANG	CHECKED BY: JTAN	APPROVED BY: KHLIM



PRODUCT SPECIFICATION

APPENDIX 1:

Contact resistance measurement

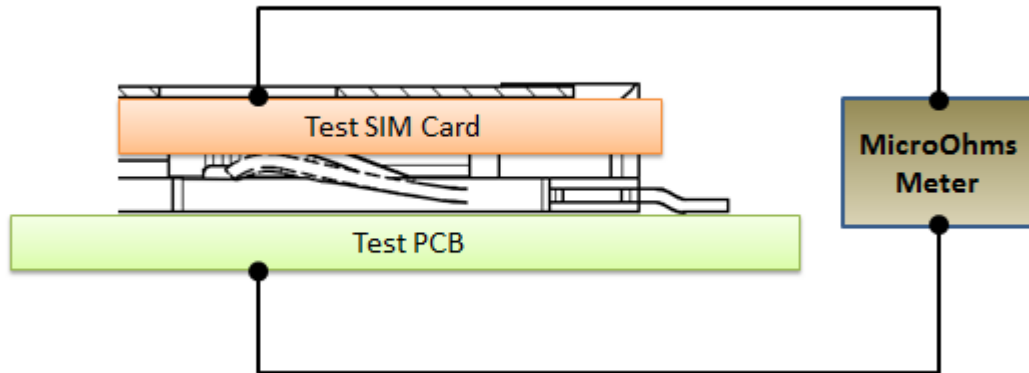

APPENDIX 2:

Contact normal force measurement

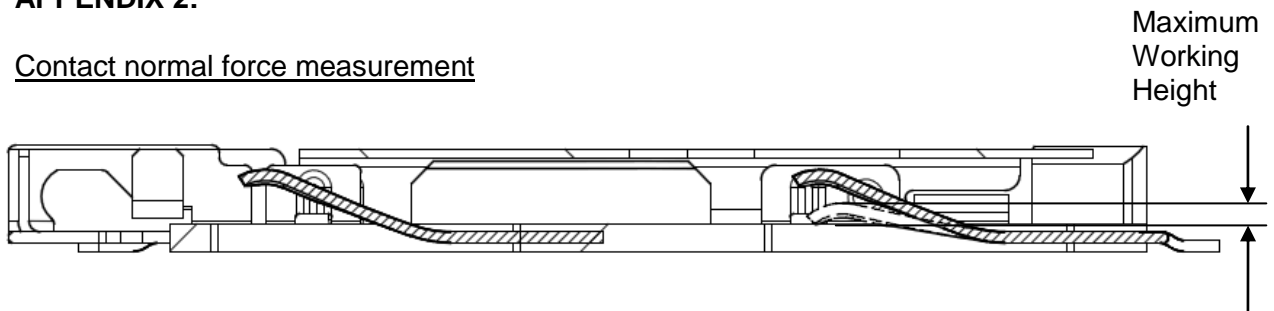

REVISION: A	ECR/ECN INFORMATION: EC No: S2015-0120 DATE: 2015/08/14	TITLE: MICRO SIM CONNECTOR, HINGE TYPE, 1.60MM MAX HEIGHT	SHEET No. 14 of 14
DOCUMENT NUMBER: PS-78800-001	CREATED / REVISED BY: EANG	CHECKED BY: JTAN	APPROVED BY: KHLIM

10 9 8 7 6 5 4 3 2 1

F

E

D

C

B

A

F

E

D

C

B

A

NOTE:

1. MATERIAL: HOUSING : LIQUID CRYSTAL POLYMER,
GLASS FILLED, UL94-V0, COLOR: BLACK
TERMINAL : PHOSPHOR BRONZE
METAL SHELL : STAINLESS STEEL
2. FINISH:
TERMINAL:-
CONTACT : 0.38µM MIN. GOLD OVER 1.27µM MIN NICKEL UNDERPLATE.
SOLDERTAIL: 1.27µM MIN. MATTE TIN OVER 1.27µM MIN NICKEL UNDERPLATE.
SHELL :-
: NO PLATING
3. PRODUCT SPECIFICATION: PS-78800-001
PACKAGING SPECIFICATION: PK-78800-001
4. SOLDERTAIL (10X) COPLANARITY 0.08MM MAX (BEFORE REFLOW).
5. CAVITY NUMBER LOCATION.
6. COMPLIANT TO RoHS DIRECTIVE 2011/65/EU AND ELV DIRECTIVE 2000/53/EC
7. MANUFACTURER ID AND DATE CODE LOCATION.
DATE CODE ON SHELL : * * * * *

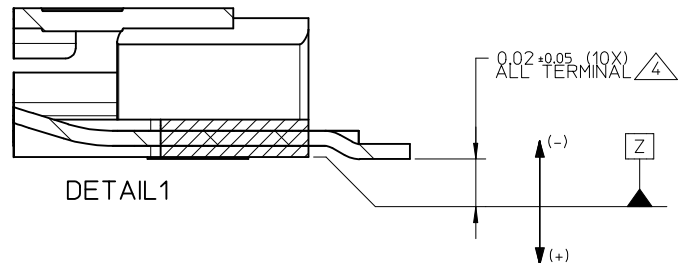
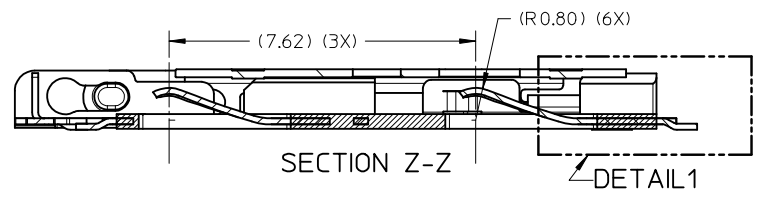
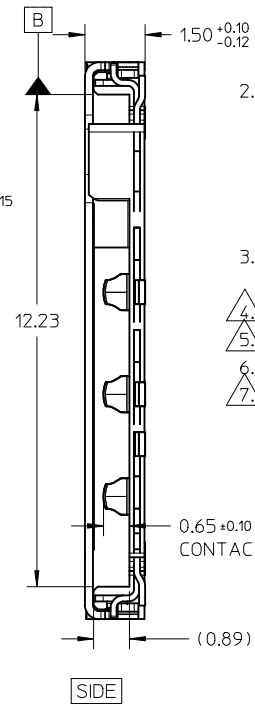
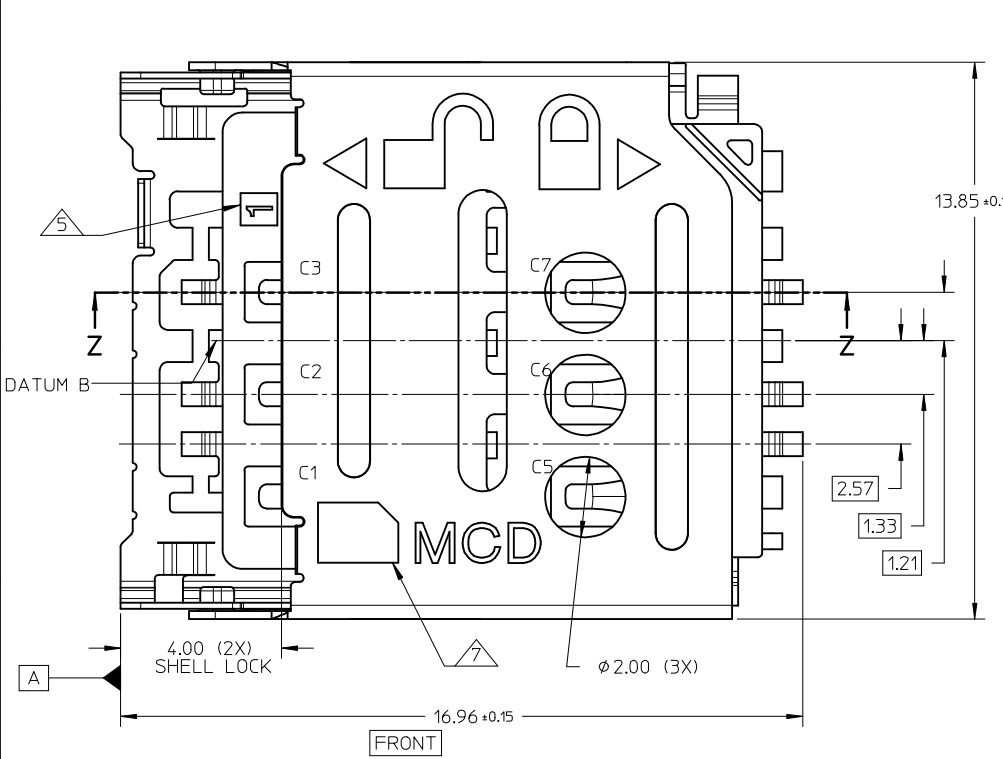
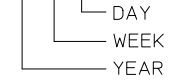

UPDATE VIEWS EC NO: S2015-0120 DRWING: EANG CHKD: JTAN02 APPR: KHLIM	DESCRIPTION REV A	QUALITY SYMBOLS	GENERAL TOLERANCES (UNLESS SPECIFIED)	DIMENSION STYLE	SCALE	DESIGN UNITS	THIRD ANGLE PROJECTION
		$F_A=0$ $F_G=0$ $F_P=0$	mm INCH 4 PLACES ± --- ± --- 3 PLACES ± --- ± --- 2 PLACES ± 0.20 ± --- 1 PLACE ± --- ± --- 0 PLACE ± --- ± ---	MM ONLY	NTS	METRIC	
		ANGULAR ± 3 ° DRAFT WHERE APPLICABLE MUST REMAIN WITHIN DIMENSIONS	DRAWN BY: EANG DATE: 2012/11/29 CHECKED BY: JTAN02 DATE: 2013/03/11 APPROVED BY: KHLIM DATE: 2013/03/14	TITLE	SALES DRAWING MICRO SIM CONNECTOR 1.50MM HEIGHT, HINGED		
		MATERIAL NO. 788000001	DOCUMENT NO. SD-78800-001	SHEET NO. 1 OF 3			

molex

THIS DRAWING CONTAINS INFORMATION THAT IS PROPRIETARY TO MOLEX INCORPORATED AND SHOULD NOT BE USED WITHOUT WRITTEN PERMISSION

9 8 7 6 5 4 3 2 1

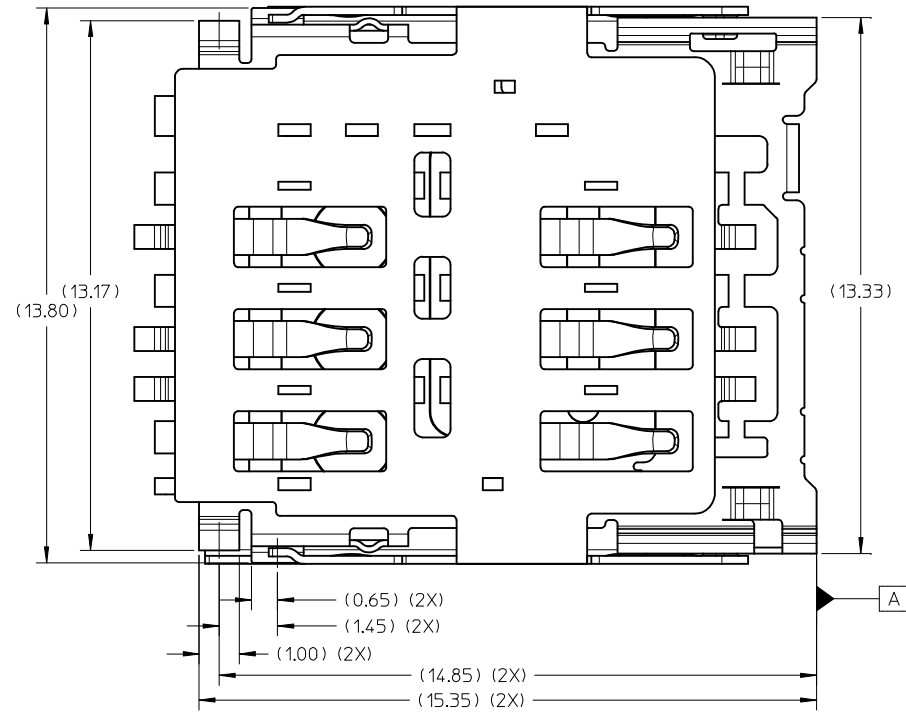
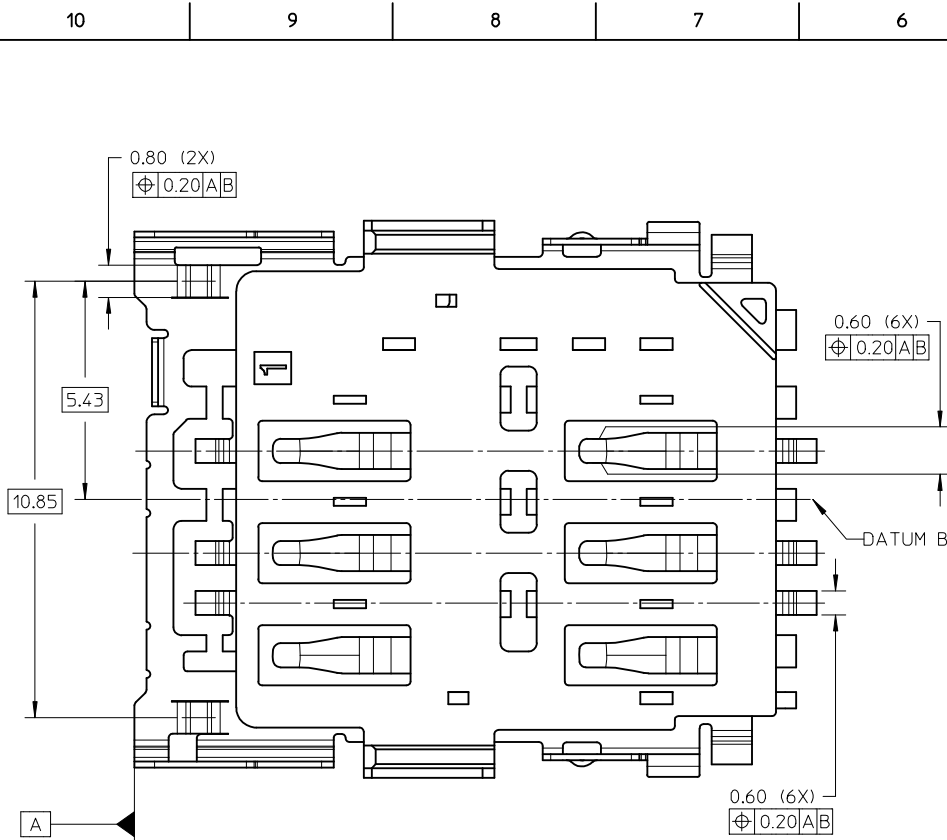

BOTTOM VIEW

REV	DESCRIPTION
A	UPDATE VIEWS

DATE	BY
2015/06/26	DRW:NEANG
2015/08/26	CHK'D:JTAN02
2015/08/27	APPR:KHLIM

QUALITY SYMBOLS	GENERAL TOLERANCES (UNLESS SPECIFIED)
$\nabla = 0$	4 PLACES \pm --- \pm ---
$\nabla = 0$	3 PLACES \pm --- \pm ---
$\nabla = 0$	2 PLACES ± 0.20 \pm ---
	1 PLACE \pm --- \pm ---
	0 PLACE \pm --- \pm ---
	ANGULAR $\pm 3^\circ$
	DRAFT WHERE APPLICABLE MUST REMAIN WITHIN DIMENSIONS

DIMENSION STYLE		SCALE	DESIGN UNITS
MM ONLY		NTS	METRIC
DRAWN BY	DATE	TITLE	
EANG	2012/11/29	SALES DRAWING	
CHECKED BY	DATE	MICRO SIM CONNECTOR	
JTAN02	2013/03/11	1.50MM HEIGHT, HINGED	
APPROVED BY	DATE	molex	
KHLIM	2013/03/14		
MATERIAL NO.	DOCUMENT NO.	SHEET NO.	
788000001	SD-78800-001	2 OF 3	

THIRD ANGLE PROJECTION	
THIS DRAWING CONTAINS INFORMATION THAT IS PROPRIETARY TO MOLEX INCORPORATED AND SHOULD NOT BE USED WITHOUT WRITTEN PERMISSION	

10 9 8 7 6 5 4 3 2 1

F

E

D

C

B

A

F

E

D

C

B

A

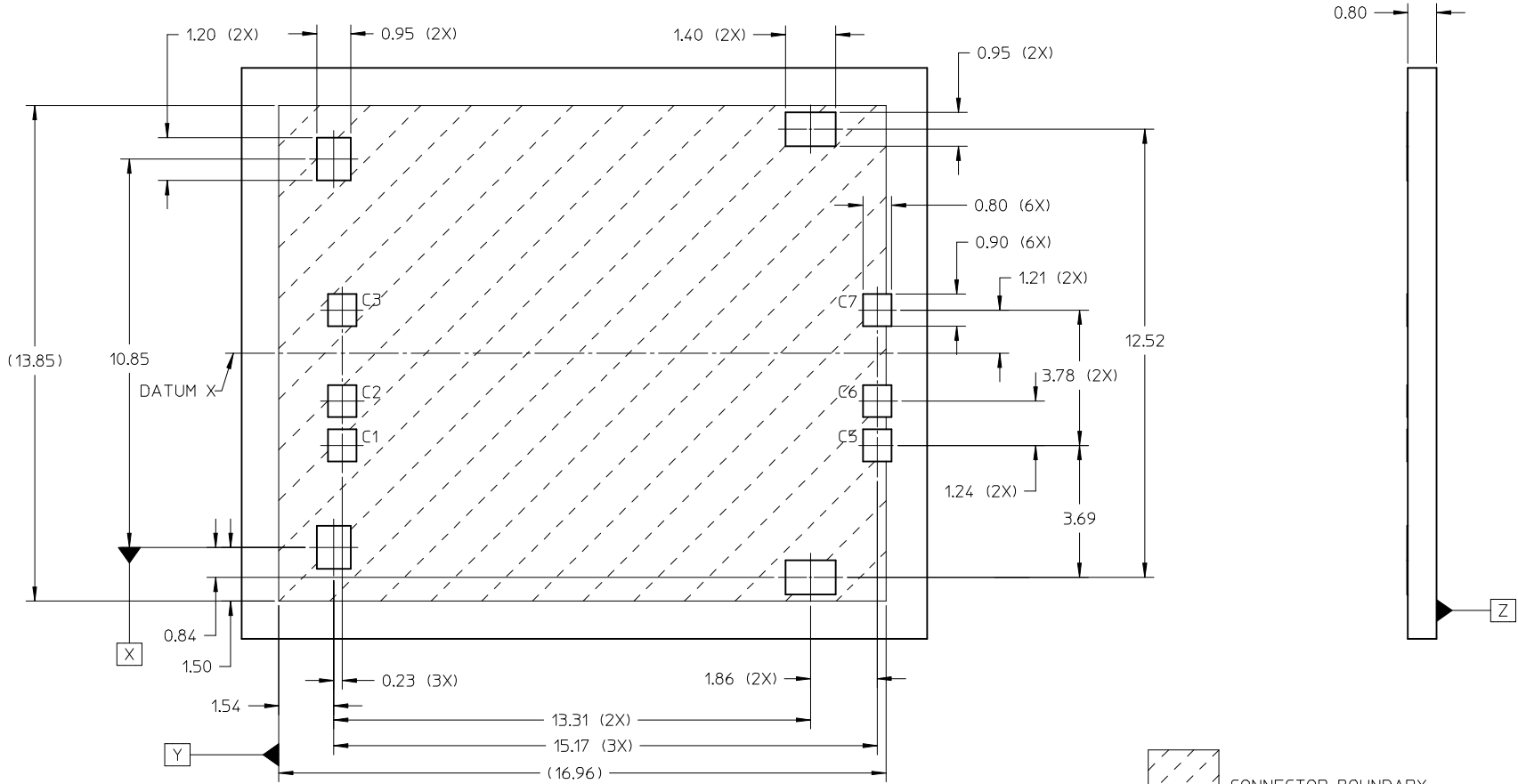

 CONNECTOR BOUNDARY
 - - - - - KEEP OUT ZONE

RECOMMENDED PCB LAYOUT
 PWB TOLERANCE: ±0.05MM

UPDATE VIEWS EC NO: S2015-0120 DRW: EANG CHKD: JTAN02 APPR: KHL IM	2015/06/26 2015/08/26 2015/08/27	DESCRIPTION A	QUALITY SYMBOLS	GENERAL TOLERANCES (UNLESS SPECIFIED)	DIMENSION STYLE	SCALE	DESIGN UNITS	THIRD ANGLE PROJECTION		
			$\nabla_A = 0$ $\nabla_C = 0$ $\nabla_P = 0$	mm INCH 4 PLACES ± --- ± --- 3 PLACES ± --- ± --- 2 PLACES ± 0.20 ± --- 1 PLACE ± --- ± --- 0 PLACE ± --- ± ---	MM ONLY	NTS	METRIC	TITLE		
			ANGULAR ± 3 ° DRAFT WHERE APPLICABLE MUST REMAIN WITHIN DIMENSIONS	DRAWN BY: EANG DATE: 2012/11/29 CHECKED BY: JTAN02 DATE: 2013/03/11 APPROVED BY: KHL IM DATE: 2013/03/14	SALES DRAWING MICRO SIM CONNECTOR 1.50MM HEIGHT, HINGED					
			MATERIAL NO. 788000001	DOCUMENT NO. SD-78800-001			SHEET NO. 3 OF 3			

9 8 7 6 5 4 3 2 1