



MC34118

LINEAR INTEGRATED CIRCUIT

VOICE SWITCHED SPEAKER-PHONE CIRCUIT

DESCRIPTION

As a voice switched speaker-phone integrated circuit, the UTC **MC34118** includes the necessary amplifiers, attenuators, level detectors and control algorithm.

To form the UTC **MC34118**'s internal circuit, there is an internal microphone amplifier with adjustable gain and mute control, internal transmit and Receive attenuators (operate in a complementary manner), level detectors at both input and output of both attenuators, and background noise monitors for both the transmit and receive channels.

The dial tone can be pretended from being attenuated by the receive background noise monitor circuit by a dial tone detector. There are also two line driver amplifiers which can be used to form a hybrid network in conjunction with an external coupling transformer. A high-pass filter can be used for other filtering functions, and especially to filter out 60Hz noise in the receive channel.

The UTC **MC34118** which requiring typically 5mA may be operated from a power supply, or it can be powered from the telephone line.

FEATURES

- * Attenuator gain range: 52dB (between Transmit and Receive)
- * For line-powered applications : 3~6.5V low voltage operation
- * For improved sensitivity :4-point signal sensing
- * For Transmit and Receive paths: background noise monitors
- * External resistors set microphone amplifier gain
- * Mute function included
- * Chip disable: active or standby operation
- * During dial tone presence: dial tone detector to inhibit receive idle mode

ORDERING INFORMATION

Normal	Ordering Number		Package	Packing
	Lead Free Plating	Halogen Free		
MC34118-D28-T	MC34118L-D28-T	MC34118G-D28-T	DIP-28	Tube
MC34118-E28-T	MC34118L-E28-T	MC34118G-E28-T	SDIP-28	Tube
MC34118-S28-T	MC34118L-S28-T	MC34118G-S28-T	SOP-28	Tube
MC34118-S28-R	MC34118L-S28-R	MC34118G-S28-R	SOP-28	Tape Reel

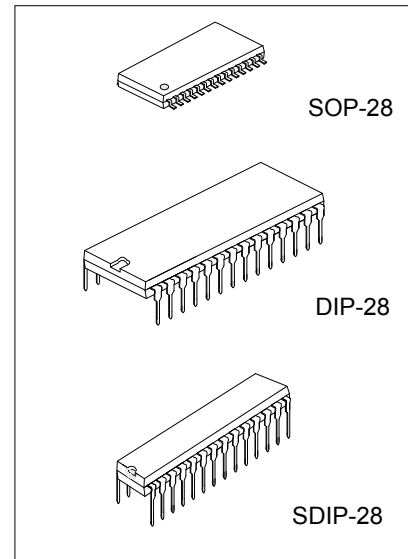

Lead-free: MC34118L
Halogen-free: MC34118G

<p>MC34118L-D28-T</p>	<p>(1) Packing Type (2) Package Type (3) Lead Plating</p>	<p>(1) T: Tube, R: Tape Reel (2) D28: DIP-28, E28: SDIP-28, S28: SOP-8 (3) G: Halogen Free, L: Lead Free, Blank: Pb/Sn</p>
-----------------------	---	--

■ PIN DESCRIPTION

PIN NO	PIN NAME	DESCRIPTION
1	FO	Output of filter. The output impedance is less than 50Ω.
2	FI	Input of filter. The input impedance is less than 1MΩ.
3	CD	Chip Disable input .A logic low (voltage lower than 0.8V) sets normal operation. A logic high (voltage higher than 2V) disable the IC. This pin's input impedance is 90 KΩ nominally.
4	V _{CC}	This pin requires a supply voltage of +2.8V ~ +6.5V at 5mA. After V _{CC} falls from 3.5V ~ 2.8V, when in the receive mode, an AGC circuit reduces the receive attenuator gain by 25dB.
5	HTO+	The output of the second hybrid amplifier. This amplifier's gain is internally set at -1.
6	HTO-	Output of the first hybrid amplifier. This amplifier's gain of the amplifier is set by external resistors.
7	HTI	The first hybrid amplifier's input and summing node. DC level is about equal to VB.
8	TXO	The transmit attenuator's output. DC level is about VB.
9	TXI	The transmit attenuator's input. It's maximum signal level is 350 mVrms. The input impedance is 10KΩ.
10	MCO	The microphone amplifier's output. This amplifier's gain is set by external resistors.
11	MCI	The summing node of the microphone's input. DC lever is VB.
12	MUT	Input of mute. A logic low (voltage lower than 0.8V) sets the circuit normal operation. A logic high (voltage higher than 2V) mutes the microphone amplifier, but it doesn't affect the rest of the circuit. The input impedance is 90 K ohms.
13	VLC	The input of Volume control. In the receive mode, when VLC=VB, the receive attenuator is at maximum gain. The receive gain is down 35dB when VLC=0.3dB, and it does not effect the transmit modes.
14	CT	At this pin, to switch modes, the RC sets the response time for the circuit.
15	VB	In this pin, there's an output voltage=V _{cc} /2 which is a system AC ground and biases the volume control. What required is a filter capacitor.
16	CPT	The time constant for the transmit background side can be set by the RC at this pin .
17	TLI2	The input to the transmit level detector which is on the microphone/ speaker side.
18	TLO2	The output to the transmit level detector which is on the microphone/ speaker side. Also the input to the transmit background monitor.
19	RLO2	The Output of the receive level detector which is on the microphone/ speaker side
20	RLI2	The input to the receive level detector which is on the microphone/ speaker side
21	RXI	The input to the receive attenuator and dial tone detector. In this pin, the maximum input level is 350mVrms,and the input impedance is 10KΩ.
22	RXO	The output of the receive attenuator. This pin's DC level is VB.
23	TLI1	The input to the transmit level detector which is on the line side.
24	TLO1	The output to the transmit level detector which is on the line side, and also the input to the transmit background monitor.
25	RLO1	The output of the receive level detector which is on the line side.
26	RLI1	The input to the receive level detector which is on the line side.
27	CPR	The time constant for the receive background monitor can be set by the RC at this pin.
28	GND	Ground.

■ BLOCK DIAGRAM

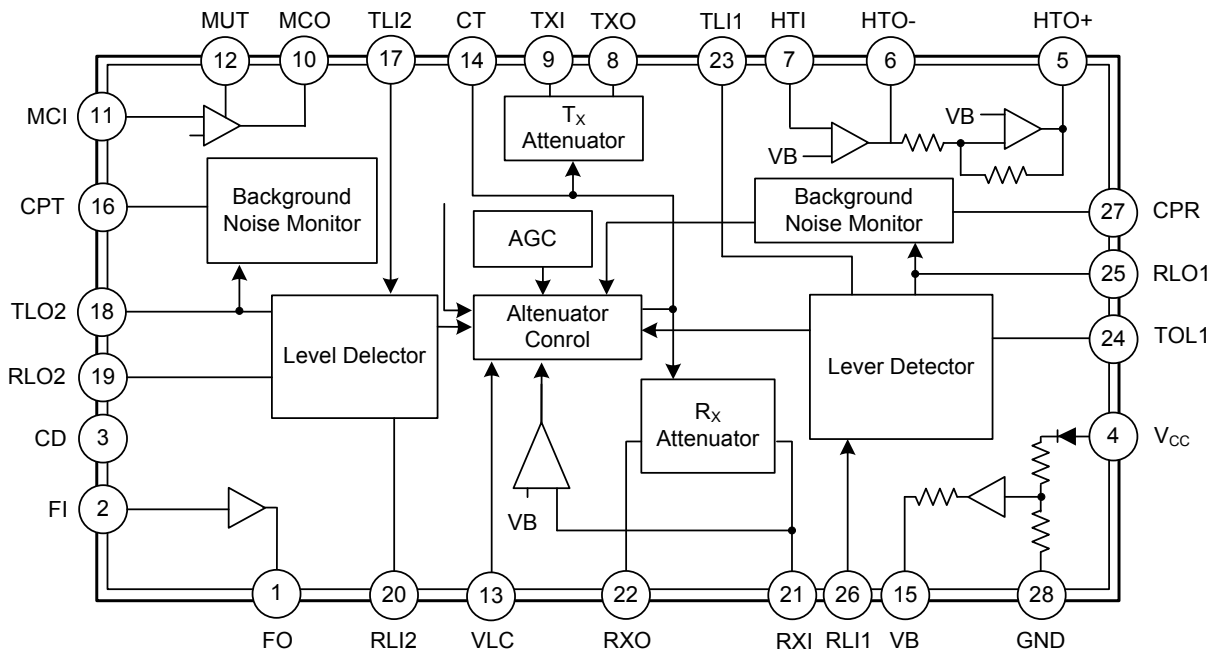

■ ABSOLUTE MAXIMUM RATING (Ta=25°C, Voltages referred to pin 22)

PARAMETER	SYMBOL	RATINGS	UNIT
Supply Voltage	V _{CC}	-1~7	V
Voltage at Pin 3	V3	-1~V _{CC} +1	V
Voltage at Pin 12 (mute)	V12	-1~V _{CC} +1	V
Voltage at Pin 13 (VLC)	V13	-1~V _{CC} +0.5	V
Voltage at Pin 9, Pin 21, and Pin 2	V9, 21, 2	-0.5~ V _{CC} +0.5	V
Storage Temperature	T _{STR}	-65~+150	°C

Note: Absolute maximum ratings are those values beyond which the device could be permanently damaged.
Absolute maximum ratings are stress ratings only and functional device operation is not implied.

■ RECOMMENDED OPERATION CONDITIONS

PARAMETER	SYMBOL	RATINGS	UNIT
Supply Voltage	V4	3.5~6.5	V
Voltage at Pin 3	V3	0~ V _{CC}	V
Voltage at Pin 12 (MUTE)	V12	0~ V _{CC}	V
Voltage at Pin 13 (VLC)	V13	0.3xV _B ~V _B	V
IVB Current (Pin 15)	I _{VB}	500	µA
Attenuator Input Signal Voltage at Pin 9, Pin 21	V9, V21	350	mVrms
Load Current	RXO, TXO(Pin8, Pin 22)	0~+2	mA
	MCO(Pin 10)	0~+1	mA
	HTO-, HTO+(Pin 6, Pin5)	0~+0.5	mA
Ambient Operating Temperature	T _{OPR}	-20~+60	°C

■ ELECTRICAL CHARACTERISTICS (Ta=25°C)

PARAMETER	SYMBOL	TEST CONDITIONS	MIN	TYP	MAX	UNIT	
Supply Voltages							
V+ Supply Current	I _{CC}	V _{CC} =6.5V, CD=0.8V		5.5	8	mA	
		V _{CC} =6.5V, CD=2V		600	800	µA	
CD Input Resistance	R _{CD}	V _{CC} =V _{CD} =6.5V	50	90		kΩ	
CD Input Voltage	High	V _{CDH}	2		V _{CC}	V	
	Low	V _{CDL}			0.8	V	
V _B Output Voltage	V _B	V _{CC} =3.5V		1.3		V	
		V _{CC} =5V	1.8	2.1	2.4		
V _B Output Resistance	R _{OVB}	I _{VB} =1mA		400		Ω	
V _B Power Supply Rejection Ratio	PSRR	C _{VB} =220µF, f=1kHz		54		dB	
Attenuators							
Receive Attenuator Gain (f=1kHz, V _{LC} =V _B)	R _X Mode, R _{XI} =150mVrms	G _{RX}	V _{CC} =5V	4	6	8	dB
	R _X Mode, R _{XI} =150mVrms	G _{RX}	V _{CC} =3.5V	4	6	8	dB
	Gain Change	ΔG _{RX1}	V _{CC} =3.5V vs. V _{CC} =5V	-0.5	0	+0.5	dB
	AGC Gain Change	ΔG _{RX2}	V _{CC} =3.5V vs. V _{CC} =5V		-25	-15	dB
	Idle Mode, R _{XI} =150mVrms	G _{RXI}		-22	-20	-17	dB
	R _X to T _X Mode Range	ΔG _{RX3}		49	52	54	dB
Volume Control Range	V _{CR}		27	35		dB	
R _{XO} DC Voltage	V _{R XO}	R _X Mode		V _B		V	
ΔR _{XO} DC Voltage	ΔV _{R XO}	R _X to T _X Mode		+10	+150	mV	
R _{XO} High Voltage	V _{R XOH}	I _{OUT} =-1mA, R _{XI} =V _B +1.5V	3.7			V	
R _{XO} Low Voltage	V _{R XOL}	I _{OUT} =+1mA, R _{XI} =V _B -1V, Output Measured with Respect to V _B		-1.5	-1	V	
R _{XI} Input Resistance	R _{R XI}	R _{XI} <350mVrs	7	10	14	kΩ	

■ ELECTRICAL CHARACTERISTICS(Cont.)

PARAMETER	SYMBOL	TEST CONDITIONS	MIN	TYP	MAX	UNIT
Transmit Attenuator Gain (f=1kHz)						
T _X Mode, T _{XI} =150mVrms	G _{TX}		4	6	8	dB
Idle Mode, T _{XI} =150mVrms	G _{TXI}		-22	-20	-17	dB
T _X to Rx Mode Range	ΔG _{TXI}		49	52	54	dB
T _{XO} DC Voltage	V _{TXO}	T _X		V _B		V
ΔT _{XO} DC Voltage	ΔV _{TXO}	T _X to R _X Mode		+30	+150	mV
T _{XO} High Voltage	V _{TXOH}	I _{OUT} =-1mA, T _{XI} =V _B +1.5V	3.7			V
T _{XO} Low Voltage	V _{TXOL}	I _{OUT} =+1mA, T _{XI} =V _B -1V, Output Measured with Respect to V _B		-1.5	-1	V
T _{XI} Input Resistance	R _{TXI}	T _{XI} <350mVrs	7	10	14	kΩ
Gain Tracking	G _{TR}	G _{RX} +G _{TX} , @T _X , I _{DIE} , R _X		+0.1		dB
Attenuator Control						
CT Voltage (CT-V _B)	R _X Mode	V _{LC} =V _B		240		mV
	Idle Mode			0		mV
	T _X Mode			-240		mV
CT Source Current	I _{CTR}	(Switching to R _X Mode)	-85	-60	-40	μA
CT Sink Current	I _{CTT}	(Switching to T _X Mode)	+40	+60	+85	μA
CT Slow Idle Current	I _{CTS}			0		μA
CT Fast Idle Internal Resistance	R _{FI}		1.5	2	3.6	kΩ
VLC Input Current	I _{VLC}			-60		nA
Dial Tone Detector Threshold	V _{DT}		10	15	20	mV
Microphone Amplifier (V_{MUT}< 0.8V, A_{VCL}=31dB, unless otherwise specified)						
Output Offset	M _{COVOS}	V _{MCO} -V _B , R _F =180 kΩ	-50	0	50	mV
Open Loop Gain	A _{VOLM}	F<100Hz	70	80		dB
Gain Bandwidth	G _{BWM}			1		MHz
Output High Voltage	V _{MCOH}	I _{OUT} =1mA, V _{CC} =5V	3.7			V
Output Low Voltage	V _{MCOL}	I _{OUT} =1mA			200	mV
Input Bias Current	I _{BM}	@MCI		-40		nA
Muting(ΔGain)	G _{MT}	f=1kHz, V _{MUT} =2V 300Hz<f<10kHz	-55	-68		dB
MUT Input Resistance	R _{MUT}	V _{CC} =V _{MUT} =6.5V	50	90		kΩ
MUT High Input Voltage	V _{MUTH}		2		V _{CC}	V
MUT Low Input Voltage	V _{MUTL}		0		0.8	V
Distortion	THD _M	300Hz<f<10kHz		0.15		%
HYBID AMPLIFIER						
HTO-Offset	H _{VOS}	V _{HTO-} ~V _B , R _F =51kΩ	-20	0	20	mV
HTO- to HTO+ Offset	H _{BVOS}	R _F =51kΩ	-30	0	30	mV
Open Loop Gain	A _{VOLH}	H _{TI} to H _{TO-} , F<100Hz	60	80		dB
Gain Bandwidth	G _{BWH}			1		MHz
Closed Loop Gain	A _{VCLH}	H _{TO-} to H _{TO+}	-0.35	0	0.35	dB
Input Bias Current(@HTI)	I _{BH}			-30		nA
HTO- High Voltage	V _{HT-H}	I _{OUT} =-5mA	3.7			V
HTO- Low Voltage	V _{HT-L}	I _{OUT} =+5mA			250	mV
HTO+ High Voltage	V _{HT+H}	I _{OUT} =-5mA	3.7			V
HTO+ Low Voltage	V _{HT+L}	I _{OUT} =+5mA			450	mV
Distortion	THD _M	300Hz<f<10kHz		0.3		%

■ ELECTRICAL CHARACTERISTICS(Cont.)

PARAMETER	SYMBOL	TEST CONDITIONS	MIN	TYP	MAX	UNIT
Level Detectors And Background Noise Monitors						
Transmit-Receive Switching Threshold(Ratio of Current at RLI1+RLI2 to 20 μ A at TLI1+TLI2 to Switch from Tx to Rx)	I_{TH}		0.8	1	1.2	
Source Current at RLO1, RLO2, TLO1, TLO2	I_{LSO}			-2		mA
Sink Current at RLO1, RLO2, TLO1, TLO2	I_{LSK}			4		μ A
CPR, CPT Output Resistance	R_{CP}	$I_{OUT} = 1.5mA$		35		Ω
CPR, CPT Leakage Current	I_{CPLK}			-0.2		μ A
Filter						
Voltage Offset at FO	F_{OVOS}	$V_{FO}-V_B$, 220k Ω from V_B to FI	-200	-90	0	mV
FO Sink Current	I_{FO}		150	260	400	μ A
FI Bias Current	I_{FI}			-50		nA
SYSTEM Distortion (f=1kHz)						
R _x Mode	THD _R	from F _i to R _{XO} , F _O connected to R _{XI}		0.5	3	%
T _x Mode	THD	from MCI to H _{TO-} /H _{TO+} , includes T _x attenuator		0.8	3	%

■ TEMPERATURE PARAMETERS

PARAMETER	TYP RATINGS (Ta=25°C)	TYP CHANGE	UNIT
V _{CC} Supply Current(CD=0.8V)	5mA	-0.3	%/°C
V _{CC} Supply Current(CD=2V)	400 μ A	-0.4	%/°C
V _B Output Voltage (V _{CC} =5V)	2.1V	+0.8	%/°C
Attenuator Gain (Max Gain)	6	0.0008	dB/°C
Attenuator Gain (Max Attenuation)	-46dB	0.004	dB/°C
Attenuator Input resistance	10k Ω	0.6	%/°C
Dial Tone Detector Threshold	15mV	20	μ V/°C
CT Source, Sink Current	$\pm 60\mu$ A	-0.15	%/°C
Microphone, Hybrid Amplifier Offset	0mV	± 4	μ V/°C
Transmit-Receive Switching Threshold	1	± 0.02	%/°C
Sink Current at RLO1, RLO2, TLO1, TLO2	4 μ A	-10	nA/°C
Closed Loop Gain(HTO- to HTO+)	0dB	0.001	%/°C

■ FUNCTIONAL DESCRIPTION

INTRODUCTION

Between operation of a speakerphone and a handset, the fundamental difference is that of half-duplex versus full-duplex. The UTC **MC34118** includes the necessary level detectors, attenuators, and switching control for a properly operating speakerphone. The detection sensitivity and timing can be externally controlled. The UTC **MC34118** also provides background noise monitors to make the circuit insensitive to room and line noise, hybrid amplifier to interface to Tip and Ring, the microphone amplifier, and other associated functions.

ATTENUATORS

The transmit and receive attenuators are complementary in function, and they are never both fully on or both fully off. For example, when one is at maximum gain: +6dB, the other is at maximum attenuation: -46dB, and vice versa. But sum of their gains remains constant at -40dB typically. To control the transmit and receive paths to provide the half-duplex operation required in speakerphone is the attenuators' purpose. The attenuators are non-inverting, have a -3dB (from max gain) frequency of ~100kHz, their input impedance of each one is nominally 10k Ω , and to prevent distortion, their input signal should be limited to 350 mVrms (same as 990mvp-p). After the output current limit (typically 2.5mA) is reached, the output impedance is < 10 Ω .

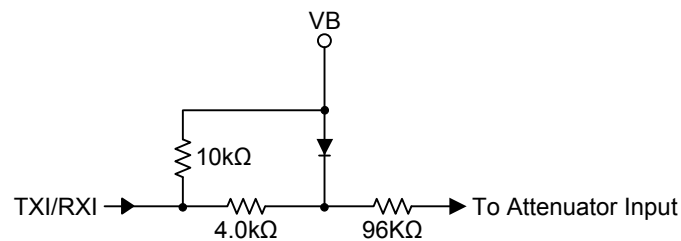

These attenuators can be controlled by the Control Block's output signal. When the CT pin which measures the signal is at +240mV with respect to VB, the circuit is in the receive mode and so receive attenuator is at +6dB. When the CT voltage is equal to VB, the circuit is in an idle mode, and it also causing the attenuators' gains to be halfway between their fully on and fully off positions (typical -20 dB each). The most direct method to monitor the circuit's mode is monitoring the CT voltage (with respect to VB).

LEVEL DETECTORS

There are two level detectors on the receive side and two level detectors on the transmit side. The terms in parentheses form one system, and the other terms form the second system. All the four level detectors are high amplifiers which have back-to-back diodes in the feedback path, and then it is resulting in non-linear gain, which permits operation over a wide dynamic range of speech levels. TLI1, TLI2, RLI1, and RLI2, the external resistor and capacitor determine the sensitivity of each level detector. Through a diode each output charges an external capacitor and limiting resistor, thus providing a DC representation of the input AC signal level. The capacitor and an internal 350 Ω resistor provide the outputs' quick rise time. And an internal current source and the capacitor set a slow decay time. On the receive side, RLI1 is at the receive input receiving the same signal as at Tip and Ring, and RLI2 is at the output of the speaker amplifier. On the transmit side, TLI2 is at the microphone amplifier, while TLI1 is at the hybrid output.

FUNCTIONAL DESCRIPTION(Cont.)

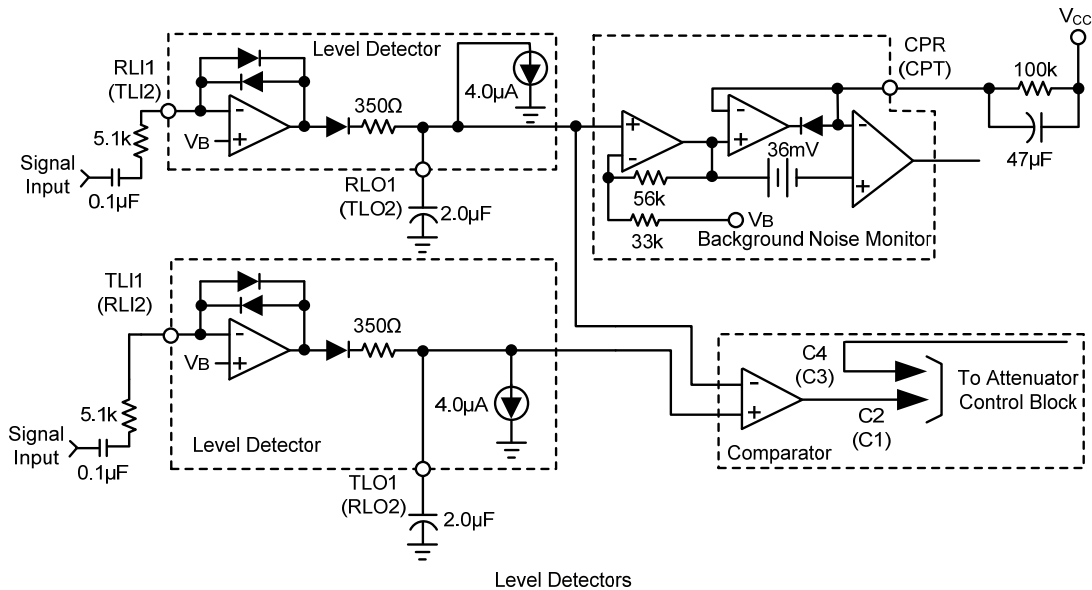

BACKGROUND NOISE MONITORS

To distinguish speech (consists of bursts) from background noise (a relatively constant signal level) is the main purpose of the background noise monitors. There is one background noise monitor for the receive path and another one for the transmit path. The receive background noise monitor is operated on by the RLI1-RLO1 level detector, as same as the transmit background noise monitor is operated on by the TLI2-TLO2 level detector. By storing a DC voltage representative of the respective noise levels in capacitors at CPR and CPT, the background noise can be monitored. At these pins, the voltages have slow rise times which determined by the external RC, but fast decay times. The voltage at the non-inverting input of the monitor's output comparator won't be more positive than the voltage at CPR/CPT when the signal at RLI1/TLI2 changes slowly. But while speech is present, it will rise quicker than the voltage at the inverting input, causing its output to change. The term's output is sensed by the attenuator Control Block.

VOLUME CONTROL

At VLC (pin 13) is the volume control input which is sensed as a voltage with respect to VB. Only in the receive mode the volume control affects the attenuators. In the receive mode, the receive attenuator's gain will be +6dB, and the transmit attenuator's gain will be -46dB when VLC is equal to VB. When VLC is reduced below VB, the receive attenuator's gain is reduced, and the transmit attenuator's gain is increased, but the sum of them tow remains constant. Out of the pin VLC, the bias current is typically 60nA.

DIAL TONE DETECTOR

This detector is a comparator with one side connected to RXI and one side input connected to VB with a 15mV offset. Under this situation: the circuit is in the receive mode, and the incoming signal is greater than 15mV, the comparator's output will change, disabling the receive idle mode. Then receive attenuator will be at a setting only determined by the volume control.

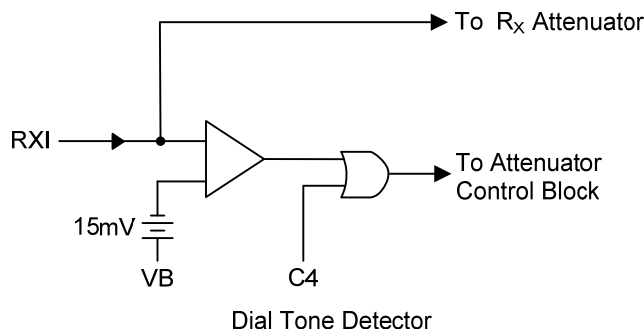

■ FUNCTIONAL DESCRIPTION(Cont.)

AGC

The AGC circuit only affects the circuit under such situation: when the circuit is in the receive mode, and when V_{CC} is less than 3.5v. As while as V_{CC} falls below 3.5 volts, the transmit path attenuation changes so that the sum of the transmit and receive gains remains constant.

ATTENUATOR CONTROL BLOCK

This block has the seven:

- * C1: The output of the comparator operated by RLO2 and TLO2 (here means in microphone/ speaker side).
- * C2: The output of the comparator operated by RLO1 and TLO1 (here means Tip/ Ring side).
- * C3: The output of the transmit background noise monitor.
- * C4: The output of the receive background noise monitor.
- * Volume control
- * Dial tone detector
- * AGC circuit

The C1~C4 effect is as follows:

INPUTS				OUTPUT
C1	C2	C3	C4	
T_x	T_x	1	X	Transmit Mode
T_x	R_x	Y	Y	Fast Idle Mode
R_x	T_x	Y	Y	Fast Idle Mode
R_x	R_x	X	1	Receive Mode
T_x	T_x	0	X	Slow Idle Mode
T_x	R_x	0	0	Slow Idle Mode
R_x	T_x	0	0	Slow Idle Mode
R_x	R_x	X	0	Slow Idle Mode

Switching to the full transmit or receive from any other mode is at the fast rate (~30 ms).

X :Don't care

Y :C3,C4 are not both 0

■ FUNCTIONAL DESCRIPTION(Cont.)

Definition of the above is as follows:

Trems	Definition
Transmit	The transmit attenuator is fully on: +6dB. And the receive attenuator is at max. attenuation :-46dB
Receive	Both attenuators are controlled by the volume control. At max. Volume the receive attenuator is fully on: +6dB, and the transmit attenuator is at max.attenuation:-46dB.
Fast Idle	Both transmit and receive speech are present in approximately equal levels. The attenuators are quickly switched to idle until one speech level dominates the other.
Slow Idle	Speech has ceased in both transmit and receive paths. The attenuators are then slowly switched to the idle mode.

A summary of the truth table is:

1. Under all the below situations the circuit will switch to transmit :
 - (1) Both transmit level detectors sense signals relative to the respective receive level detectors
TLI1 versus RLI1, TLI2 versus RLI2
 - (2) The transmit background noise monitor indicates the presence of speech.
2. Under all the below situations the circuit will switch to receive
 - (1) Both receive level detectors sense higher signal levels relative to the respective transmit level detectors
 - (2) The receive background noise monitor indicates the presence of speech.
3. Under all the below situations the circuit will switch to the fast Idle mode:
 - (1) If the level detectors disagree on the relative strengths of the signal levels
 - (2) At least one of the background noise monitor indicates speech.

There are two conditions which can cause the fast idle mode to occur:

 - (A) When both talkers are attempting to gain control of the system by talking at the same time
 - (B) When one talker is in a very noisy environment, forcing the other to continually over-ride that noise level. In general, the fast idle mode will occur infrequently.
4. Under any of the below situations the circuit will switch to the slow idle mode
 - (1) Both talkers are quiet(no speech present)
 - (2) When one talker's speech level is continuously over-ride by noise at the other speaker's location.
CT pin (pin14) determine the time required to switch the circuit between transmit, receive, fast idle, and slow idle.
A schematic of the CT circuitry operates as follows:
 - * RT =120kΩ (typ.), and CT =5μF (typ.).
 - * Switching to the receive mode
I1 is turned on; I2 is off,
Charging the external capacitor to +240mV above VB
An internal clamp prevents further charging of the capacitor).
 - * Switching to the transmit mode
I2 is turned on; I1 is off,
Bringing down the voltage on the capacitor to -240mV with respect VB.

FUNCTIONAL DESCRIPTION(Cont.)

- * Switch to idle quickly,
 The current sources are turned off,
 The internal 2kΩ resistor is switched in
 Discharging the capacitor to VB with a time = 2kΩ x CT.
- * Switching to idle slowly
 The current sources are turned off
 The switch at the 2kΩ resistor is open
 Discharging the capacitor to VB through the external resistor RT with a time=RT x CT.

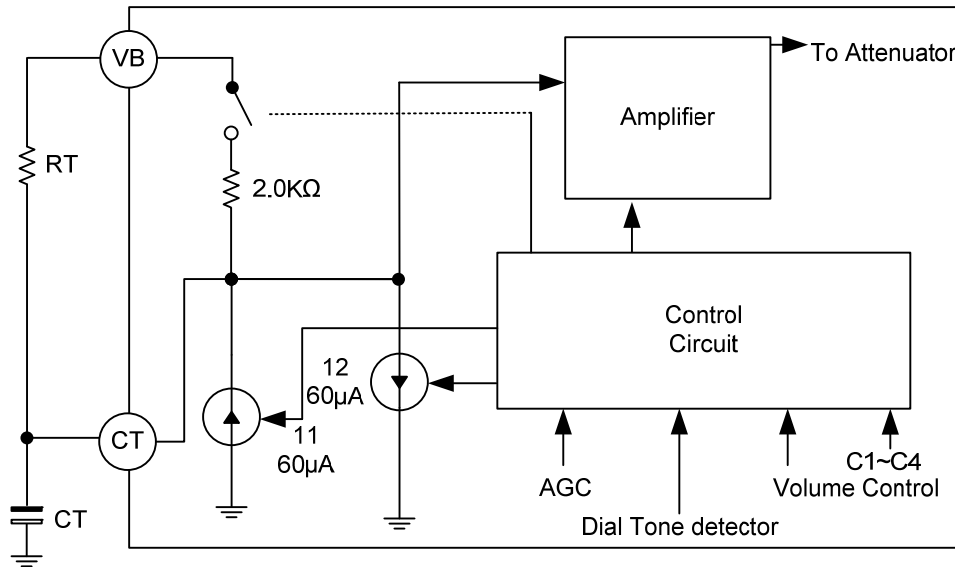

CT Attenuator Control Block Circuit

MICROPHONE AMPLIFIER

While the inverting input and the output are pinned out, pins 10/11, the microphone amplifier, has the non-inverting input internally connected to VB. This amplifier's open loop gain is typically 80dB when $f < 100\text{Hz}$, and the gain bandwidth is typically 1MHz. Its maximum output swing (p-p) is typically 1 volt. MCI's input bias current is typically 40nA out of the pin.

HYBRID AMPLIFIER

At HTO+, HTO-, and HTI, the two hybrid amplifiers provide the two-to-four wire converter for interfacing to the telephone line. The first amplifier's gain is set by external resistor, and the first amplifier's output drives the second amplifier (gain of -1).

FILTER

The external components determined the operation of the filter circuit.

POWER SUPPLY, VB, and CHIP DISABLE

For normal operation the power supply voltage is to be between 3.5v and 6.5v, but with reduced operation the V_{CC} is possible 2.8 volts. VB's output voltage is $\sim (V_{CC}-0.7)/2$, and also provides the AC ground.

■ TYPICAL APPLICATION CIRCUIT

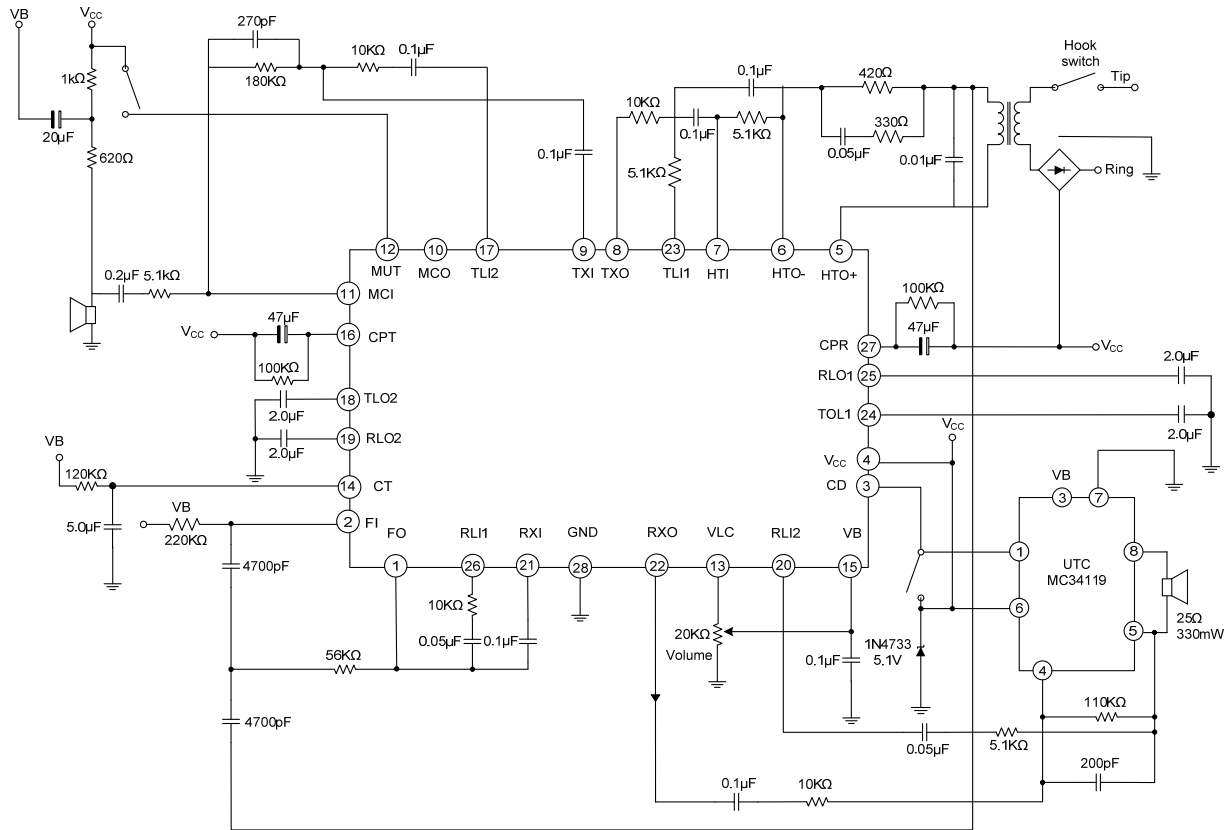

UTC assumes no responsibility for equipment failures that result from using products at values that exceed, even momentarily, rated values (such as maximum ratings, operating condition ranges, or other parameters) listed in products specifications of any and all UTC products described or contained herein. UTC products are not designed for use in life support appliances, devices or systems where malfunction of these products can be reasonably expected to result in personal injury. Reproduction in whole or in part is prohibited without the prior written consent of the copyright owner. The information presented in this document does not form part of any quotation or contract, is believed to be accurate and reliable and may be changed without notice.