

KV ELECTRONICS CO., LTD.

988 MOO 2, SOI THETSABAN BANG PU 60
 TUMBOL THAI BAN , AMPHUR MUANG
 SAMUTPRAKARN 10280
 TEL. +66(0) 2701-2969 , FAX +66(0) 2701-2966
 E-MAIL : kvea@loxinfo.co.th

Customer name : Electronic source
 Customer part no. : ES00187
 Drawing no. :
 Description : Transformer EE-19
 KV no. : 14253
 Revision : 02



Issue date
 July 18, 2014

Check by *[Signature]*

Approve by *[Signature]*

Revise record.

Rev.	Date	Revise description	Page.
01	22-Jul-14	- Change from BOBBIN EI-19 , 10 Pin (Vertical type) to BOBBIN EE-19 , 10 Pin (Horizontal type) in Components list.	2
02	07-Nov-14	- Add pull pin 4,7,8,9 out in drawing.	2



1. Components list.

<u>Item.</u>	<u>Material.</u>	<u>Manufacturer.</u>
1. Bobbin EE-19	Phenolic (UL94V-0)	Chang chun plastic co., ltd UL no. E59481(S). or equivalent.
2. Core EE-19/16/5	PC40	Xuyi or equivalent.
3. Copper wire	Polyurethane enameled copper (130 deg.c).	Thai Hitachi enamel wire co., ltd. UL no. E137472. Pacific-Thai electric wire & cable co.,ltd. UL no. E142108.
4. T.I.W. wire	Tripple insulating wire (130 deg.c)	Dah Jin Technology.co.,ltd UL no. E236542.
5. Insulation tape	Polyester #1350F-1 (130 deg.c) Polyester #35660 (130 deg.c)	3M UL No.E17385. Symbio INC UL.no. E50292.
6. Kapton tape	Polyimide film insulating tape with silicone base adhesive, Cat. No. KA180K	Symbio Inc. UL No.E50292.
7. Solder bar	Sn / Cu	Ultra core or equivalent.
8. Varnish	Ultimeg 2000/380	A.E.V PLC UL no. E220579 or equivalent.

The drawing and dimension in milimetre unit.

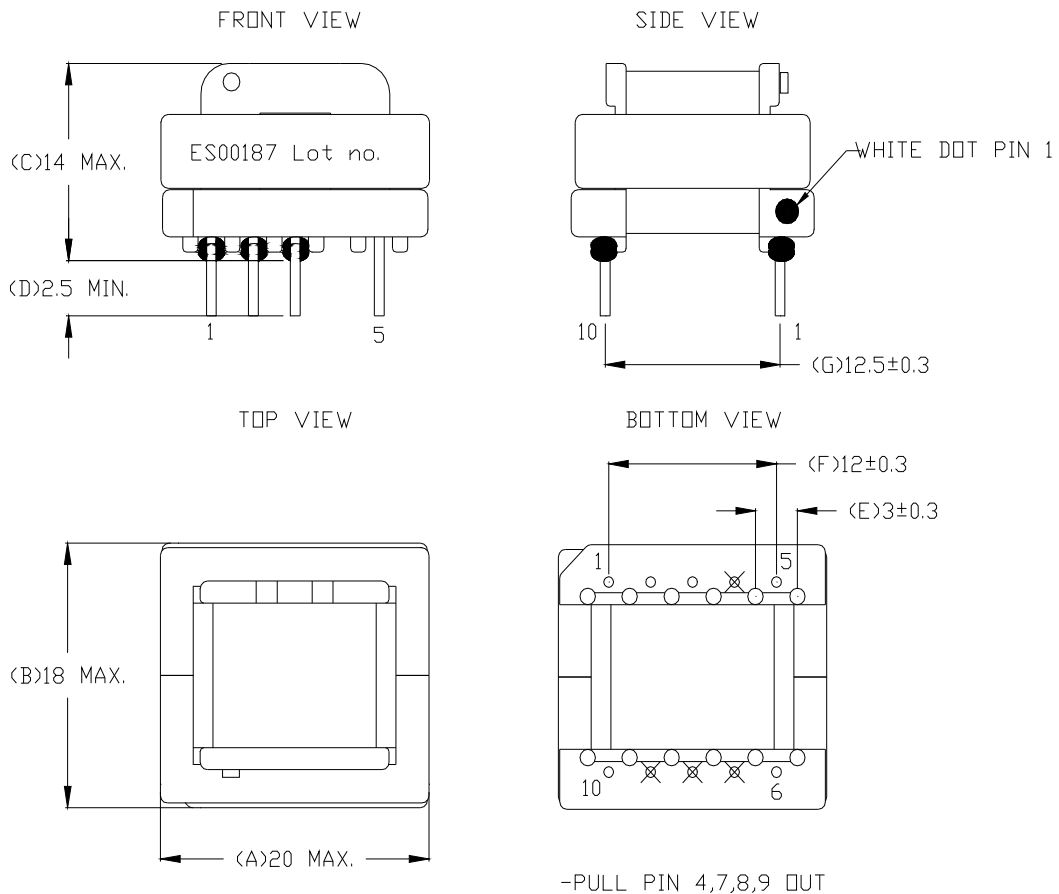

KV ELECTRONICS CO., LTD.

988 MOO 2, SOI THETSABAN BANG PU 60
 TUMBOL THAI BAN , AMPHUR MUANG
 SAMUTPRAKARN 10280
 TEL. +66(0) 2701-2969 , FAX +66(0) 2701-2966
 E-MAIL : kvea@loxinfo.co.th

Customer name : Electronic source
 Customer part no. : ES00187
 Drawing no. :
 Description : Transformer EE-19
 KV no. : 14253
 Revision : 02



2. Schematic diagram and winding instruction.

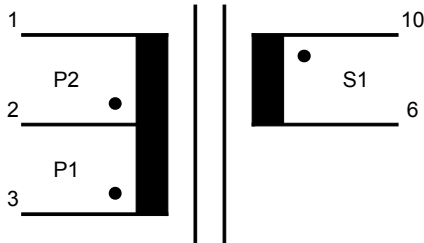

- P1 Pin 3 – 2 = Wire 0.40 mm. / 38 Ts.
Insulation 3 Ts.
- S1 Pin 10 – 6 = TEX-E Wire 0.40 mm. X3 / 4 Ts.
Insulation 3 Ts.
- P2 Pin 2 – 1 = Wire 0.40 mm. / 37 Ts.
Insulation 3 Ts.

Note :

3. Electricals specification and test data (at 25 deg.c).

Item	Pin no.	Specification	Test data										
			1	2	3	4	5						
Inductance (L) At 10KHz, 1V	3 – 1	839.00 uH +/-10%	846.50	894.40	864.40	919.30	842.90						
Leakaged Inductance At 10KHz, 1V (LK) (Shorted 6,10)	3 – 1	60.00 uH Max.	27.23	30.92	29.05	28.05	24.45						
DC-Resistance (DCR)	3 – 1	0.45 Ohm Max.	0.34	0.34	0.34	0.34	0.34						
Voltage ratio test. I/P 3-1, 20KHz, 1Vrms	10 – 6	0.046 – 0.060 Vrms	0.053	0.053	0.053	0.053	0.053						
Hi-Potential test. 1mA 50Hz	Apply 2000Vac between P1,P2 to S1 for 2 sec. Apply 1500Vac between wire to core for 2 sec.									Passed	Passed		
Phase check follow to schematic diagram.									Passed				

Mechanical test
Sample no.

	A	B	C	D	E	F	G
1	19.50	17.49	13.22	3.5	2.94	11.97	12.70
2	19.47	17.49	13.16	3.5	2.97	12.04	12.66
3	19.63	17.35	13.07	3.5	2.97	12.08	12.65
4	19.53	17.46	13.15	3.5	2.92	12.02	12.66
5	19.66	17.37	13.08	3.5	2.95	12.05	12.66

Test date : July 24, 2014
 Test by : Apiwat