



# SHENZHEN BREE LIGHTING Co., LIMITED

Bld. M & J, Maoyuan Industrial Park, Zhangkengjing, Guanlan, Baoan, Shenzhen, Guangdong, China

Tel : +86-755-29739398/29676092

Fax: +86-755-89328498

E-mail: [sales@breeighting.com](mailto:sales@breeighting.com)

Web: [www.breeighting.com](http://www.breeighting.com)

## < Specifications >

### MEAN WELL DRIVER & BREE DRIVER

Version:A1

(PIC) Model No.				
	BR-HBL100W-02(ID:TCK)	BR-HBL150W-02(ID:TCK)	BR-HBL200W-02(ID:TCK)	BR-HBL240W-02(ID:TCK)

### Photoelectric Spec

Item	Power	Input Voltage	Input Frequency	Leds	Power Factor	LuminousFlux	Beam Angle	Weight
BR-HBL100W-02(ID:TCK)	100W	AC100-240V	50/60HZ	PHILIPS 3030	>0.9	13000 Lm	120°	3.7 kg
BR-HBL150W-02(ID:TCK)	150W	AC100-240V	50/60HZ	PHILIPS 3030	>0.9	19500 Lm	120°	5.24 kg
BR-HBL200W-02(ID:TCK)	200W	AC100-240V	50/60HZ	PHILIPS 3030	>0.9	26000 Lm	120°	7.27 kg
BR-HBL240W-02(ID:TCK)	240W	AC100-240V	50/60HZ	PHILIPS 3030	>0.9	31200 Lm	120°	7.27 kg

### Light Source Spec

LED Type	PHILIPS 3030
Color Accuracy(CRI)	CRI>80
Color	WW(3000-3500K) NW(4000-4500K) CW(5000-6500K)

### Power options

MEAN WELL DRIVER	HBG series A:Conventional HBG series B:Dimmable 1-10V
BREE DRIVER	Conventional

### Environment Spec.

Operational Temperature Range	-20~50
Preservation Temperature Range	-40~60
Operational Humidity Range	95% Rh or below(@-20°C~50°C)
Installation Area	Outdoor:IP65( Factory, warehouse, gymnasium,etc)
Lifespan	>35,000 hours

### Certification standard



### Dimension Diagram

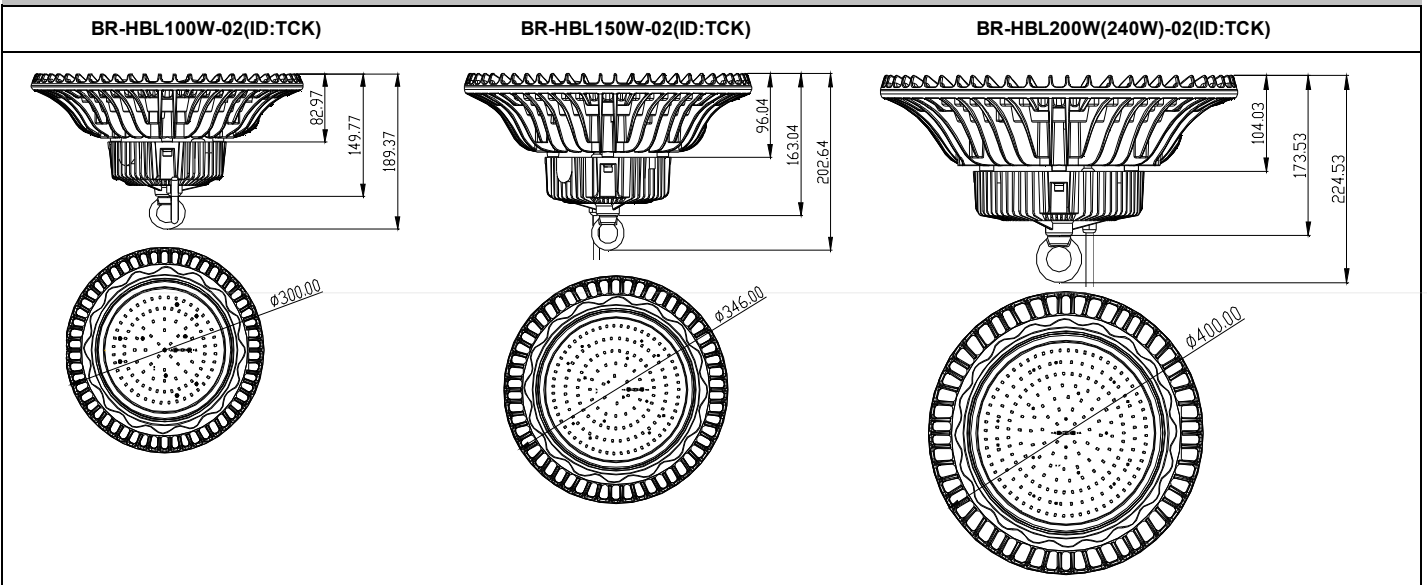

Optical Spec

BR-HBL100W-02  
(ID:TCK)

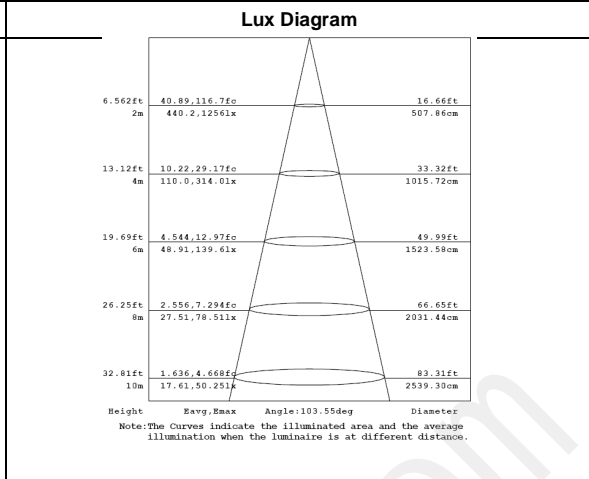
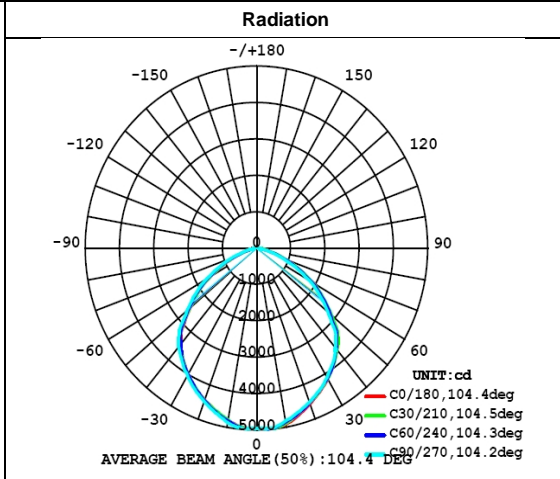

BR-HBL150W-02  
(ID:TCK)

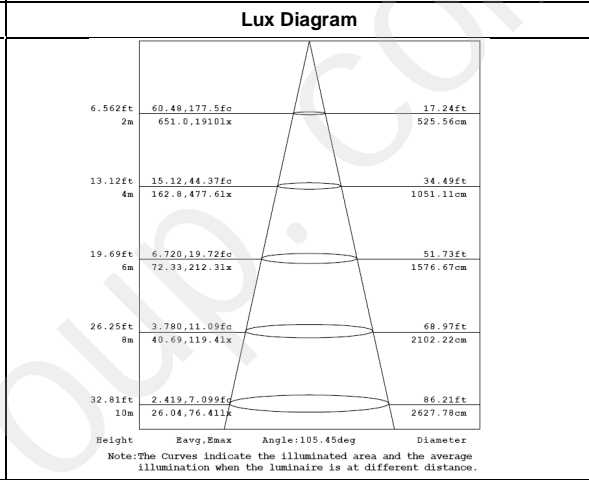
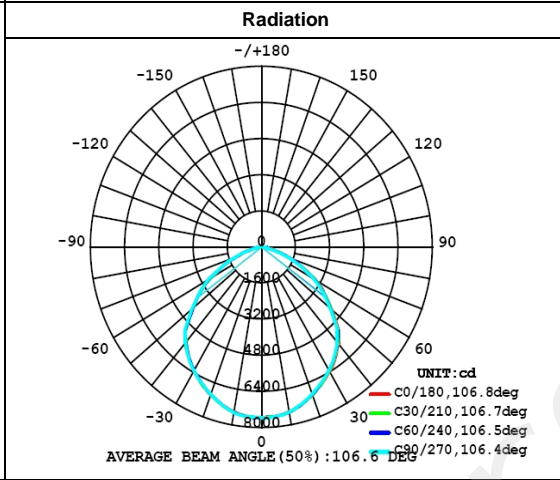

BR-HBL200W-02  
(ID:TCK)

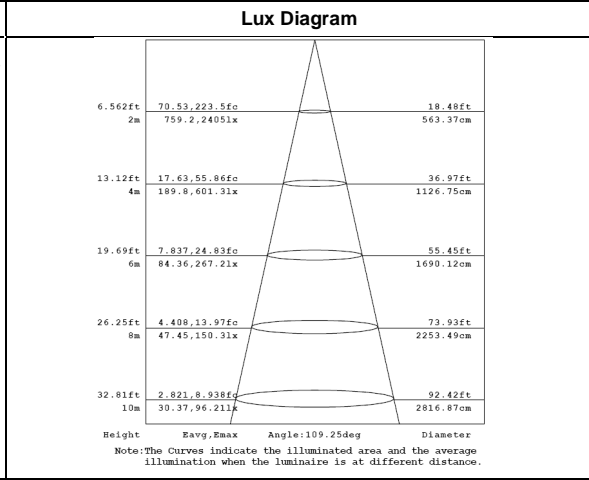
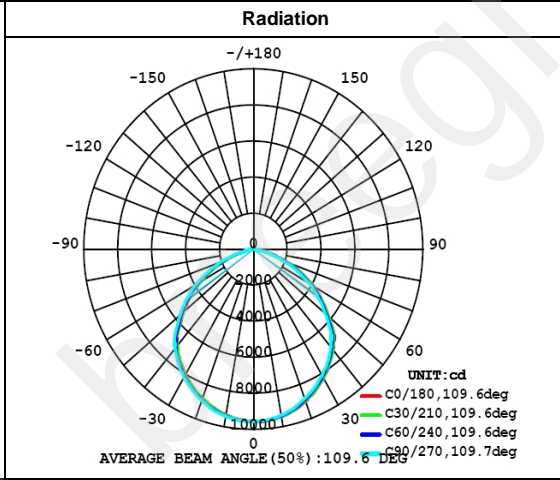

BR-HBL240W-02  
(ID:TCK)

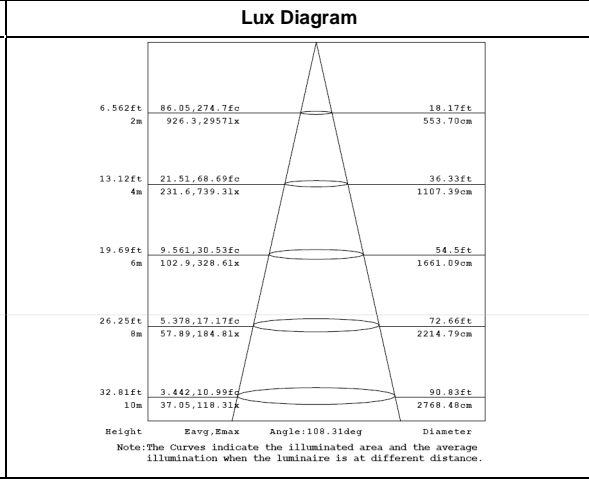
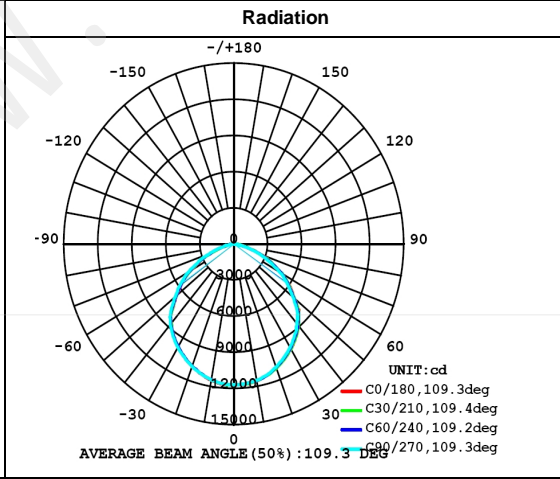

## Model Options

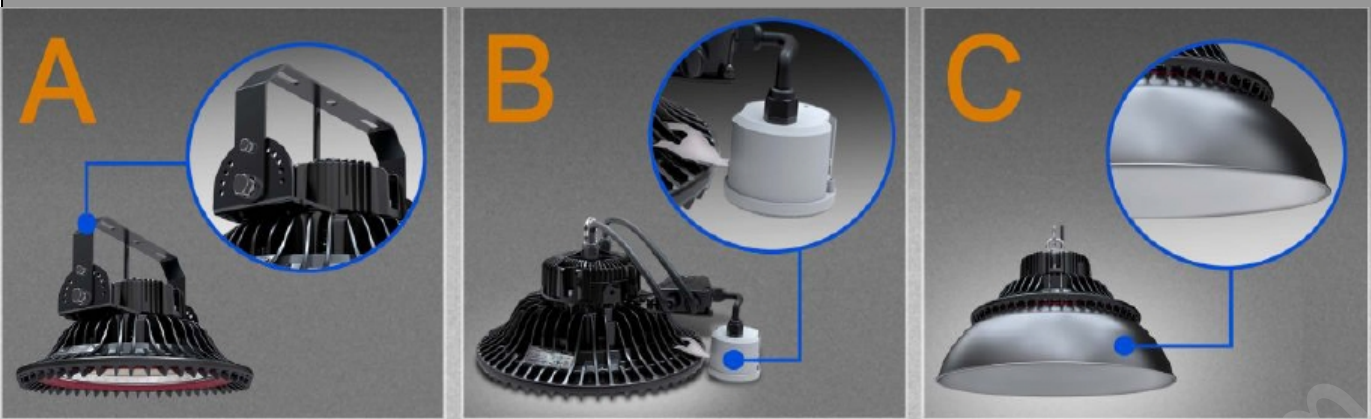

### Bracket

Available for  
BR-HBL-02TA/TC,  
more installation ways.

### Radar Sensor

Available for  
BR-HBL-02TA/TC  
series, more energy-saving  
(60%Lm than standard  
highbay)

### Reflector(90°)

Available for  
BR-HBL-02TC/TD,  
better to control  
angle.

## Radarsensor parameters

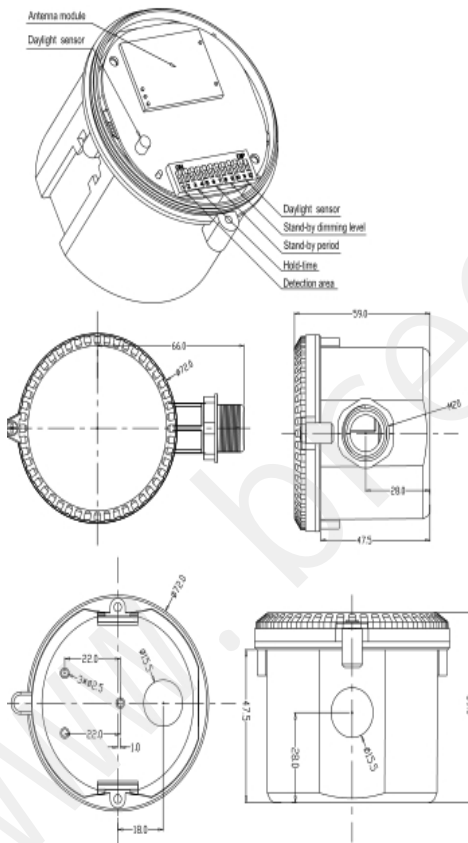

Operating voltage	120~277Vac, 50Hz/60Hz
Rated load	400W@120Vac, 800W@220-277Vac (inductive) 800W@120Vac, 1200W@220-277Vac (resistive)
HF system	5.8GHz±75MHz, ISM wave band
Transmitting power	<0.5mW
Power consumption	≤0.8W(standby), <1.5W(operation)
Detection zone	Max.(D x H): 16m x 15m
Detection sensitivity	100% / 50%
Hold time	5s / 30s / 90s / 3min / 20min / 30min
Daylight sensor	50lux / 100lux / 200lux / Disable
Stand-by period	5s / 5min / 10min / 30min / 1h / +∞
Stand-by dimming level	10% / 20% / 30% / 50%
Mounting height	15m Max.
Motion detection	0.5~3m/s
Detection angle	150°(wall installation), 360°(ceiling installation)
Operating temperature	-35℃~70℃



## Installation and use

Step1.Hang on the lamp on the roof of the hook

Installation is finished,please make sure the wire is properly connected,and turn on the power,make the light on.

### LED Highbay Light

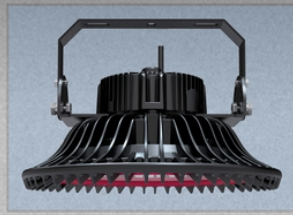

### Installation Information

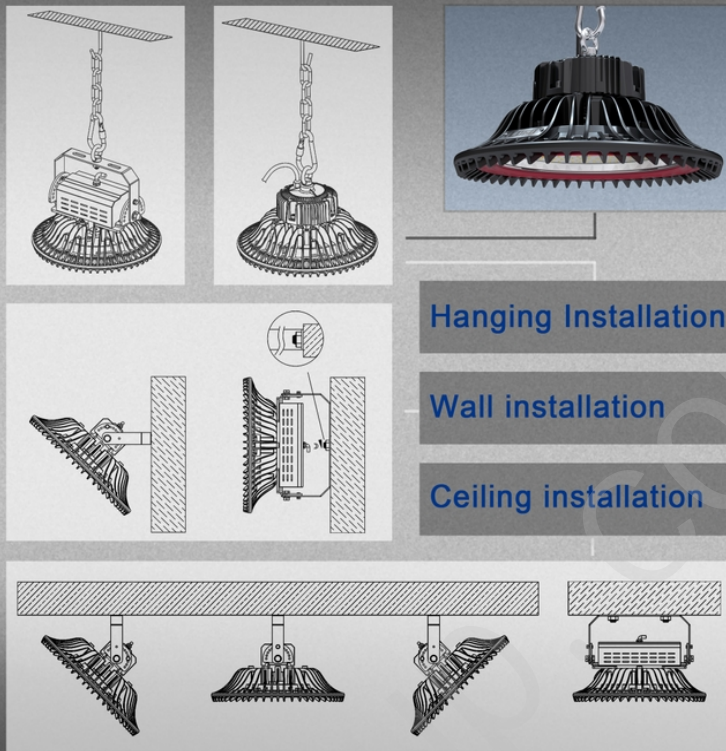
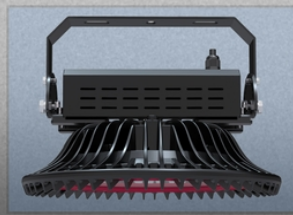

### Attention

1. Please turn off the power supply before installation or changing assembly parts.
2. The input voltage and the lamp should be adapted. After connecting the power line, please make sure the wiring section is insulated.
3. Non-professionals, must not install or dismantle the lamps.
4. All the lights during installation and in use should not be put with glass cover vertically upside.

### Packing Spec

Item	Box			Carton		
	Measurement (mm)	Gross weight	Pcs/box	Measurement(mm)	Gross weight	Pcs/carton
BR-HBL100W-02(ID:TCK)	L370*W370*H230	3.7 kg	1	L400*W400*H495	8.56kg	2
BR-HBL150W-02(ID:TCK)	L420*W420*H250	5.24kg	1	//	6.38 kg	1
BR-HBL200W-02(ID:TCK)	L470*W470*H260	7.27kg	1	//	8.54kg	1
BR-HBL240W-02(ID:TCK)	L470*W470*H260	7.27kg	1	//	8.54kg	1

### Remarks:

1. White light series: WW (3000-3500K) NW (4000-4500K) CW (5000-6500K)
2. Luminous flux tolerance for  $\pm 10\%$
3. Products shall be subject to any changes without prior notices.

Light attenuation map

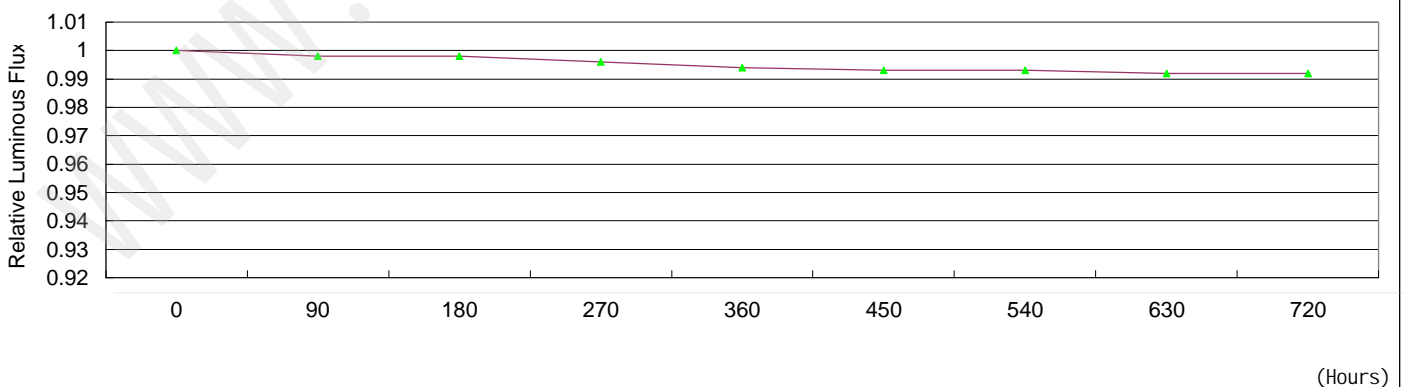

Through the 720H accelerated aging test,high and low temperature prediction in the rated under the working conditions after 35000H,will provide an average 70% optic maintenance ratio(L70).