

MALE
PART_NO: G575007SM

FEMALE
PART_NO: G575008SM

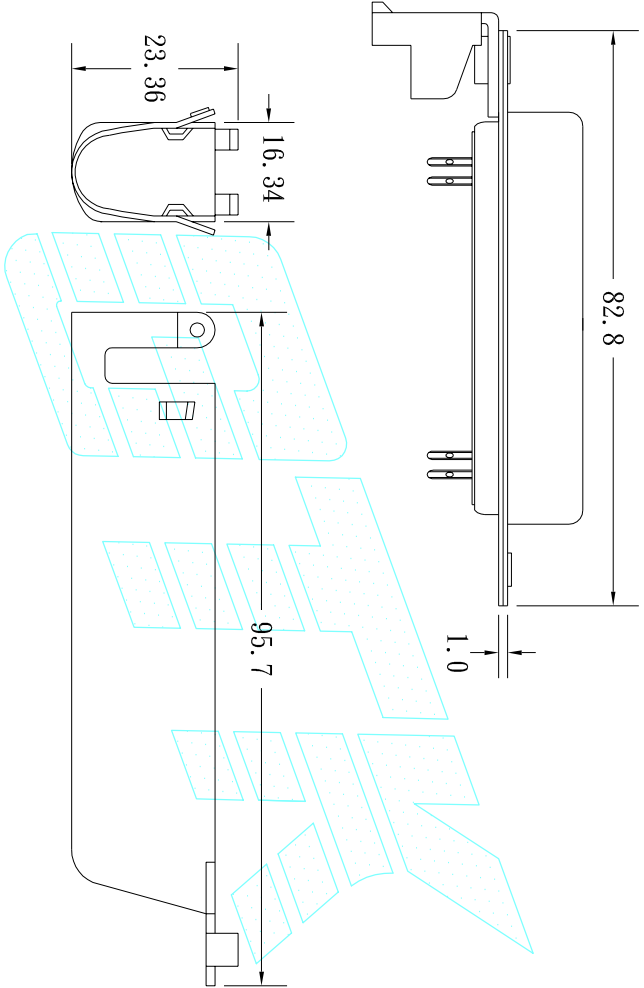

MATERIAL & FINISH
*SHELL: STEEL
ZINC PLATED TIN PLATED
OR NICKEL PLATED STEEL
*PIN CONTACT: PHOSPHOR BRONZE OR BRASS
*INSULATOR: PBT & GLASS-FIBER REINFORCED UL-94-V0
*NUMBER OF CONTACT: 50
*CURRENT RATING: 5 AMP
*DIELECTRIC STRENGTH: 1000V FOR ONE MINUTE
*INSULATOR RESISTANCE: 1000MΩ MIN. (AT 500V DC)
*TEMPERATURE: -55 °C TO +105 °C
*COVER: METAL

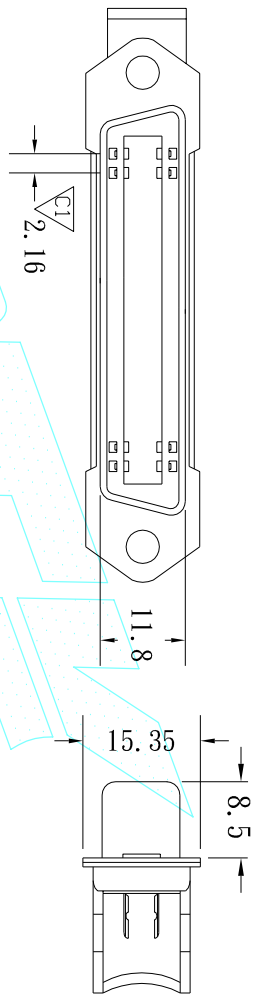
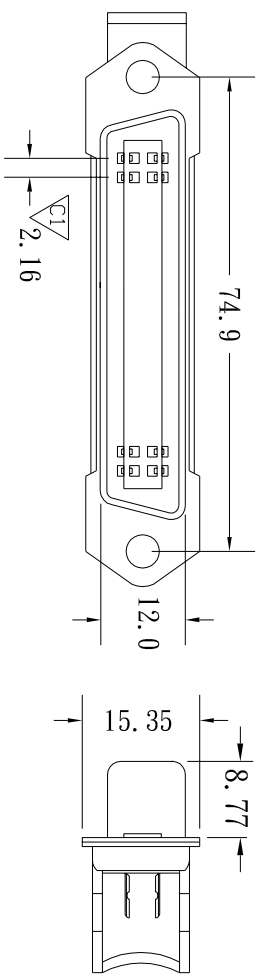
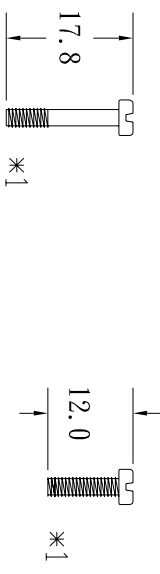

4#40UNC

4#40UNC

NOTE: 1. DIMENSIONS MARKED ∇ TO BE CHECKED BY GTK QC

TOLERANCE UNLESS OTHERWISE SPECIFIED		PROJECTION			TITLE	PART NO.	GOLD-TEK ELECTRIC CO., LTD.
LINEAR	ANGLE	UNITS	MM				
X. ±	X°. ±	MM	MM	CENTRONIC SOLDER	CAD NO. 1047	G57500*SM	
.XX ± 0.20	.X°. ±	SCALE		SIDE ENTRY TYPE	F:\Draw\CEN\CEN-0028		
.XXX ± 0.05	.XXX°. ±	SIZE	A4	IPART NO			
APPD							
CHKD							
DRAW	Tao. Tao.						
	JUN. 20. 2002						

圖面編號:GTKSD0917-B(1)

REV	ECN NO.	DESCRIPTION	DATE
A		RELEASE	FEB. 20. 02
B		ADD SCREWS	JUN. 20. 02