

LOGO	REV.	Date	Changes
①			
②			
③			

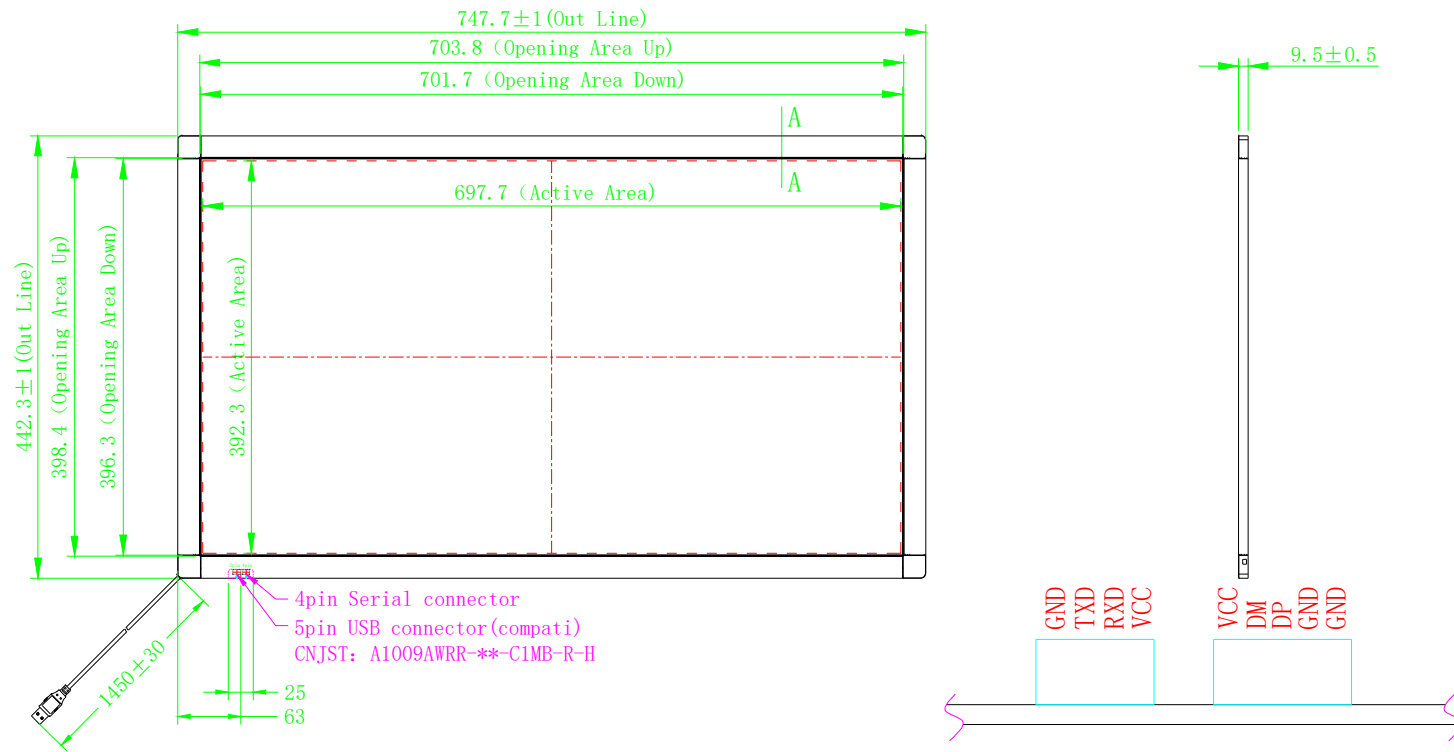

PIN脚定义

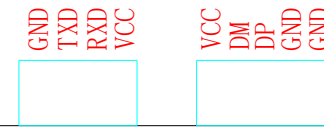

注：未注公差±0.2mm

A-A
10:1

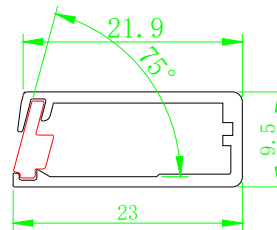

TOLERANCES (UNLESS OTHERWISE STATED)	
DECIMALS	ANGLES ±0.5°
>2000mm	±2.00mm
1600 < X ≤ 2000mm	±1.20mm
1200 < X ≤ 1600mm	±0.80mm
800 < X ≤ 1200mm	±0.50mm
400 < X ≤ 800mm	±0.40mm
120 < X ≤ 400mm	±0.30mm
30 < X ≤ 120mm	±0.20mm
≤ 30mm	±0.10mm

THIRD ANGLE PROJECTION



MODEL NO.	FG系列			NOTES:
PART No.	FG315BD-CTA7	SCALE	1:1	
PART NAME	产品尺寸图	REV.	1.0	
UNIT	mm	SIZE	FREE	
MATERIAL		SHEET	1/1	
SURFACE		CHK' D		
DRAWN		APP' D		