



普耀集團有限公司
POLYSHINE HOLDINGS LTD.
東莞福哥電子有限公司

FAVOR UNION ELECTRONICS(DONG GUAN)CO., LTD.

SPECIFICATION

Please sign
After Approval
承认后请
将该份签回

Customer's Name:

Spec. No.	F-24K-01-008
Issue Date	2021/03/26

No.	Model Name	Customer's No.
1	F24KP-0119A	
2		
3		
4		
5		

Marketing Dept.	Production Dept.	Quality Dept.	Engineering Dept.

Customer's Approval		

香港沙田火炭坳背灣街34-36號豐盛工業中心A座14樓15-16室

Unit 15-16, 14/F., Block A, Veristrong Ind. Ctr.,
34-36 Au Pui Wan St., Fotan, Shatin, N.T.H.K.

電話(Tel): (852)2687 2282

傳真(Fax): (852)2687 2320

E-mail: polyshine@polyshinehk.com.hk

Website: <http://www.polyshine.cn>

中國廣東省東莞市茶山鎮劉黃管理區第五工業區
5th Industrial Area, LiuHuang Management Area,
ChaShanTown, DongGuan, GuangDong, China.

電話(Tel): (0769) 8664 2764 (0769) 8664 3404

傳真(Fax): (0769) 8664 5674



東莞福哥電子有限公司
FAVOR UNION ELECTRONICS(DONG GUAN)CO., LTD



普耀集團有限公司
POLYSHINE HOLDINGS LIMITED



廣西欽州福晟電子有限公司
FAVORSHINE ELECTRONICS
(QINZHOU GUANGXI)CO.,LTD.

陳紀豪 業務部副經理

JONATHAN CHAN DEPUTY SALES MANAGER

HK Mobile: 9271 0829 China Mobile: 13143861040

E-mail: jonathanchan@polyshinehk.com.hk

地址: 香港沙田火炭坳背灣街34-36號豐盛工業中心A座14樓15-16室

電話(Tel): (852)2687 2282 傳真(Fax): (852)2687 2320

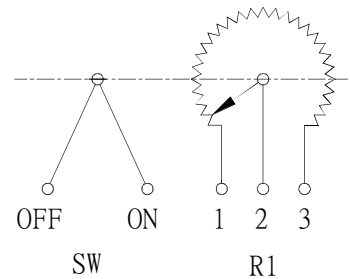
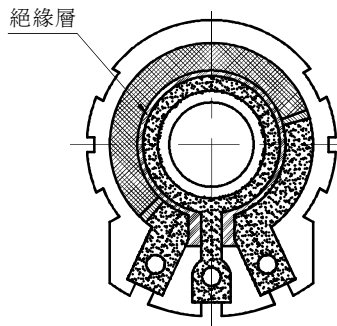
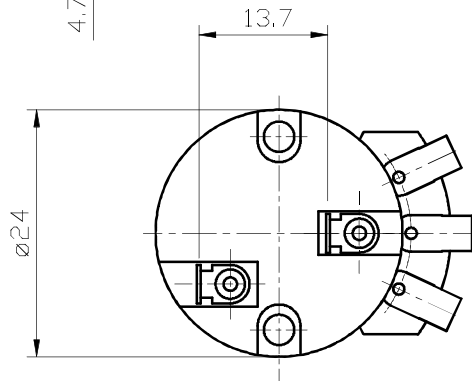
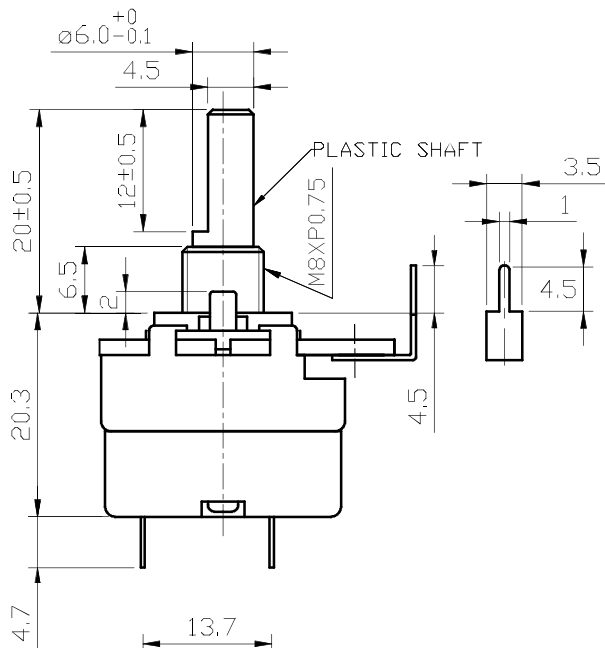
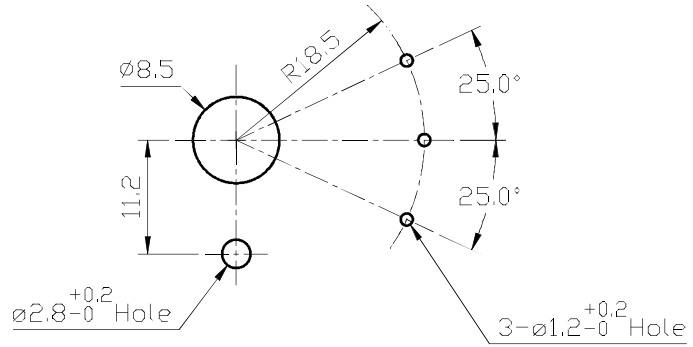
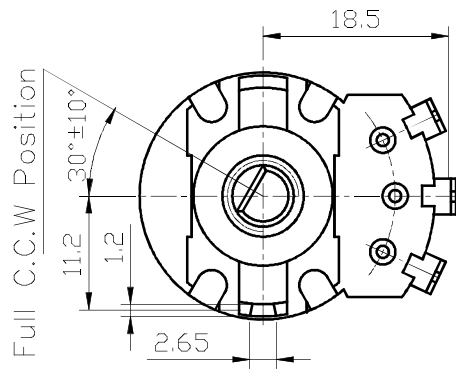

CIRCUIT

未指定容許±尺寸之公差	
10以下	±0.3
10~100	±0.5
100以上	±0.8
角度	±5°

普羅集團有限公司
 POLYSHINE HOLDINGS LTD.
 東莞福哥電子有限公司
 FAVOR ELECTRONICS (DONG GUAN) CO., LTD.

MTL	SPEC	DISPOSAL				
△5			UNIT	SCALE	TITLE	
△4			MM	1.5/ 1	F-24K Series	
△3			DRAWN	DESIGN	CHECK	DWG NAME
△2			羅 濤	羅 濤		F24KP-0119A
△1			2021.03.26	羅 濤	鍾振華	DWG NO.
DEVISION	DATE	DESIGN				



普耀集團有限公司
POLYSHINE HOLDINGS LTD.
東莞福哥電子有限公司

FAVOR ELECTRONICS (DONG GUAN) CO., LTD.
(ROTARY) POTENTIOMETER SPECIFICATIONS

(旋轉式)規格書

編號 NO. : F-24K-01-008

公司名稱 CO. Name :

型號名稱 Model Name : F24KP-0119A

DOCUMENT CONTROLLED

26 MAR 2021

福哥電子有限公司
FAVOR ELECTRONICS CO.,LTD

ENG. DEPT

一. ELECTRICAL CHARACTERISTICS 電氣特性

日期 (DATE): 2021/03/26

序號 NO.	項目 ITEM	性能 PERFORMANCE	測試條件 TEST CONDITIONS
1.1	Total resistance 全阻值	500KΩ±10%	Between terminal 1 and terminal 3. 1-3 端子間。
1.2	Resistance taper 阻抗特性型式	Type B Refer to attached drawing "Resistance taper characteristics". B 型 見所附"阻型特性圖".	It should be tested at the position of 50% of the effective use angle. Percentage of the voltage of (C、E、RD type terminal 2-3 and other type terminal 1-2)to the voltage of terminal 1-3. 在有效使用角度的 50% 的位置測定, (C、E、RD 阻型其端子 2-3 腳, 其它 阻型其端子 1-2 腳)電壓對端子 1-3 腳電 壓的百分比。
1.3	Rated power 額定功率	<input checked="" type="checkbox"/> Linear taper B: 0.5W <input type="checkbox"/> Other tapers : 0.25W <input checked="" type="checkbox"/> B 型 : 0.5W <input type="checkbox"/> 其它阻型 : 0.25W	The rated power should be changed according to the following chart when the ambient temperature changed. 它與環境溫度按以下曲線變化。 DERATING CURVE OF RATED DISSIPATION

1.4	Rated voltage 額定電壓	<input checked="" type="checkbox"/> Linear taper B: AC500V <input type="checkbox"/> Other tapers : AC250V <input checked="" type="checkbox"/> B 型 : AC500V <input type="checkbox"/> 其它阻型 : AC250V	$E = \sqrt{PR}$ E:額定電壓 Rated voltage(V) P:額定電力 Rated power(W) R:公稱阻值 Normal total resistance(Ω) The rated voltage is calculated by above formula. When the rated voltage exceeds the maximum operating voltage, the maximum operating voltage should be the rated voltage. 額定電壓按以上公式計算，當額定電壓超過最大工作電壓時，最大工作電壓即為額定電壓。
1.5	Sliding noise 雜訊	Less than 100 mV 小於 100mV	By JIS method
1.6	Insulation resistance 絕緣阻抗	More than 100M Ω 100M Ω 以上	Measure insulation resistances between the individual terminals and metallic case with a DC500V insulation resistance tester. 外殼與端子間加 DC500V 電壓測定。
1.7	Withstand voltage 耐電壓特性	Without arcing or breakdown 無損壞或弧光	Apply AC 1080V between specified terminals and metallic case for 1 minute. 在特定端子與金屬外殼間加 AC1080V 電壓 1 分鐘。
1.8	Residual Resistance 殘留電阻值	Term1-2: Less than 10 Ω Term2-3: Less than 10 Ω 1-2 端子間：小於 10 Ω 2-3 端子間：小於 10 Ω	Resistance between terminal 1-2 and terminal 2-3 in full CW rotation and full CCW rotation. 軸以逆時針方向和順時針方向旋轉到底時 1-2 與 2-3 腳之阻值。

二.MECHANICAL CHARACTERISTICS 機械特性

序號 NO	項目 ITEM	性能 PERFORMANCE	測試條件 TEST CONDITIONS
2.1	Total Rotation angle 全回轉角度	300°±10°	
2.2	Rotational Torque 旋轉力矩	20~150 gf.cm	Rotational speed 60°/sec 回轉速度: 60°/秒
2.3	Rotation Stopper Strength 旋轉止動強度	There should be no visual damage when minimum 5.0 Kgf.cm of torque are applied. 當其承受最小 5.0Kgf.cm 之扭力時，無明顯破壞及損傷	Test duration: rotate to terminal 1 and terminal 3 specifically for 10±1 sec. 測試時間: 旋轉至 1 腳端和 3 腳端各 10 ±1 秒。
2.4	Push-Pull Strength of Shaft 軸心推拔承受強度	There should be no broken when Maximally 10.0 Kgf of push strength and 10.0 Kgf pull strength are applied. 應用 10.0Kgf 的推力及 10.0Kgf 的拉力，無損傷	Test duration: 10 sec. of push force immediately followed by 20 sec. of pull force should be applied. Test point and direction: The strength should be applied to the top end of the shaft in axial direction. 測試時間: 應用推力 10 秒鐘后立即應用拉力為 20 秒鐘; 測試點及方向: 測試點為軸心頂部，方向為軸向。

2.5	Shaft play in axial direction 軸向間隙	0.4mm Max. 最大為 0.4mm	Apply 0.5kgf of force to the shaft in axial direction. 沿軸心軸向方向施加 0.5kgf 拉拔力。
2.6	Shaft Wobble 軸心晃動	0.7XL/30mm Max. L—Shaft length L—軸心長度	Apply 0.5kgf force perpendicular to the shaft at the position of 5mm to the top end of the shaft. 在距軸心頂端 5mm 處加 0.5kgf 且與軸心垂直的力。
2.7	Bushing nut tighten Strength 軸套螺母緊固強度	8.0Kgf.cm Min 最小為 8.0Kgf.cm	

三. ENDURANCE CHARACTERISTICS 耐久性能

序號 NO	項目 ITEM	性能 PERFORMANCE	測試條件 TEST CONDITIONS
3.1	Dry heat 耐熱性	Variation of total resistance should be within $\begin{matrix} +5\% \\ -30\% \end{matrix}$. To be operated mechanically. 全阻值變化要在 $\begin{matrix} +5\% \\ -30\% \end{matrix}$ 以內， 機械方面能動作。	Test temperature: $80 \pm 2^\circ\text{C}$ Test duration: $240 \pm 8\text{h}$ Exposure to room temperature: 1h to 2h. 測試溫度 $80 \pm 2^\circ\text{C}$ ， 時間 240 ± 8 小時， 室溫保持 1 至 2 小時。
3.2	Cold 耐寒性	The total resistance change should be within $\pm 20\%$. To be operated mechanically. 全阻值變化要在 $\pm 20\%$ 以內， 機械方面能動作。	Test temperature: $-30 \pm 3^\circ\text{C}$ Load condition: No load Low temperature exposure: $96 \pm 4\text{h}$ Exposure to room temperature: 1h to 2h 測試溫度 $-30 \pm 3^\circ\text{C}$ ，無負載， 時間 96 ± 4 小時，室溫保持 1 至 2 小時。
3.3	Damp heat 耐濕性	Insulation resistance: more than $10\text{M}\Omega$ with 250V insulation resistance tester. The total resistance change should be within 20%. To be operated mechanically. 用 250V 絕緣測試機測試，絕緣阻抗 $10\text{M}\Omega$ 以上。 全阻值變化要在 $\pm 20\%$ 以內。 機械方面能動作。	Place the tested samples in the thermostat with the temperature $40 \pm 2^\circ\text{C}$ and 90% to 95% of the relative humidity for 96 ± 4 hrs, then drop off water and proceed test. 測試溫度 $40 \pm 2^\circ\text{C}$ ，濕度 90% 至 95%， 時間 96 ± 4 小時，並在恆溫箱外擦干水珠后立即測試。

3.4	Temperature characteristic 溫度特性	<p>Variation rate of resistance unit: % 阻值變化率單位:%</p> <table border="1" data-bbox="480 170 922 490"> <thead> <tr> <th rowspan="2">Nominal total resistance(R)</th> <th colspan="2">Resistance law</th> </tr> <tr> <th>B</th> <th>Other tapers</th> </tr> </thead> <tbody> <tr> <td>$R \leq 10K \Omega$</td> <td>within +5 -20</td> <td>within +5 -20</td> </tr> <tr> <td>$R > 10K \Omega$</td> <td>within +5 -25</td> <td>within +5 -30</td> </tr> </tbody> </table>	Nominal total resistance(R)	Resistance law		B	Other tapers	$R \leq 10K \Omega$	within +5 -20	within +5 -20	$R > 10K \Omega$	within +5 -25	within +5 -30	<p>Test temperature: $70 \pm 3^{\circ}C$ Test duration: 5h 測試溫度 $70 \pm 3^{\circ}C$，時間 5 小時。</p>
Nominal total resistance(R)	Resistance law													
	B	Other tapers												
$R \leq 10K \Omega$	within +5 -20	within +5 -20												
$R > 10K \Omega$	within +5 -25	within +5 -30												
3.5	Salt mist 鹽霧試驗	<p>No apparent rust and discoloration 無明顯銹跡,無變色</p>	<p>Test should be made with temperature of $35 \pm 2^{\circ}C$ and concentration of $5 \pm 1\%$ (by weight) for 16 h. Then clean with water. 在溫度為 $35 \pm 2^{\circ}C$,濃度(重量比)為 $5 \pm 1\%$ 的條件下,進行 16 小時連續噴霧后取出水洗.</p>											
3.6	Vibration 振動	<p>To be operated mechanically. No rotation abnormality. Electrical characteristics are as usual. 機械方面能動作，轉動無異常，電氣性能正常。</p>	<p>Place the shaft to the half-way of full rotation. Parts should be secured to a 10Hz and 55Hz logarithmic vibration machine by a mounting device. The test should be made with the vibration direction of X,Y, Z 3 directions perpendicular to the actuator and 2 hours for each direction. Leave the test sample in the room temp for 1-2 hrs. 把折動子停留在中間位置,然後把電位器放在頻率為 10Hz 與 55Hz 的正弦振動器上來回振動,在 X,Y,Z 三個方向,每一個方向振動 2 小時,然後在室溫放置 1 至 2 小時.</p>											
3.7	Solder ability 焊錫性	<p>Not less than 3/4 of the surface dipped shall be covered with new solder. 浸錫部分表面最少 3/4 被新錫覆蓋。</p>	<p>Temperature of solder: $235 \pm 5^{\circ}C$ duration: $3 \pm 0.5s$. 焊錫溫度 $235 \pm 5^{\circ}C$，浸錫時間 3 ± 0.5 秒。</p>											
3.8	Resistance to soldering heat 焊錫耐熱性	<p>Variation of total resistance shall be within $\pm 5\%$, and terminals shall not work loose to injure electric contact, after test. 全阻值變化 $\pm 5\%$ 以內,測試後無端子鬆動,不會損壞電氣接點。</p>	<p>Solder dip: 浸焊 Preheating condition: Surface temperature of the substrate shall be settled within $100^{\circ}C$ in one min. 預熱: 基板表面溫度 $100^{\circ}C$ 以下, 1 分鐘內。 Solder temperature $260 \pm 5^{\circ}C$ for 5 sec. 焊錫溫度 $260 \pm 5^{\circ}C$，5 秒。 Manual Soldering: Less than $350^{\circ}C$ and quicker than 3 seconds. 手鐸: $350^{\circ}C$ 以下, 3 秒以內。</p>											

3.9	Rotational life 旋轉壽命	Standard life 標準壽命： Variation of total resistance should be within $\pm 15\%$, Sliding noise should be within 150 mV. 全阻值變化 $\pm 15\%$ 以內，雜訊 150mV 以內。 Long life 長壽命： Variation of total resistance should be within $\pm 20\%$, Sliding noise should be within 300 mV. 全阻值變化 $\pm 20\%$ 以內，雜訊 300mV 以內。	<input checked="" type="checkbox"/> Standard life 標準壽命： 15,000 cycles Min 15,000 次以上。 <input type="checkbox"/> Long life 長壽命： 100,000 cycles Min 100,000 次以上。
-----	-------------------------	---	--

四、SWITCH CHARACTERISTICS (FOR WITH-SWITCH TYPE)

開關規格(適用於帶開關機種)

序號 NO.	項目 ITEM	性能 PERFORMANCE	測試條件 TEST CONDITIONS
4.1	Contact resistance of switch. 開關接觸電阻	Less than 50 m Ω 小於 50m Ω	Tested by contact resistance tester when switch is ON (1KHZ,20mV, 5~50mA). 開關處於 ON 狀態時，以(1KHZ,20mV, 5~50mA)微電流接觸阻抗計測定.
4.2	Switch Rated Power 開關額定功率	1.0A at DC 125V 1.0A at AC 125V	Within 70 $^{\circ}$ C 小於 70 $^{\circ}$ C
4.3	Insulation resistance 絕緣阻抗	More than 100 M Ω 100 M Ω 以上	Measure insulation resistances between the switch terminals and metallic case with a DC500V insulation resistance tester. 金屬外殼與開關端子間加 DC500V 電壓測定.
4.4	Withstand voltage 耐電壓	There shall be no damage arc or dielectric breakdown. 無絕緣破壞之現象	Apply AC 1080V(50~60HZ) between switch terminals and metallic case for 1 minute. 在開關端子與金屬外殼間加 AC 1080V (50~60HZ)電壓 1 分鐘
4.5	Switch rotation angle 開關回轉角度	50 \pm 10 $^{\circ}$	
4.6	Switch action 開關作用力	300 ~800 gf.cm	
4.7	Number of cycles 開關耐久次數	Contact resistance 200m Ω Max, To be operated mechanically. 接觸阻抗最大 200m Ω , 機械方面能動作.	<input checked="" type="checkbox"/> 15,000 Cycles min <input type="checkbox"/> Other / Cycles min

五.General 一般事項

序號 NO	項目 ITEM
----------	------------

	Unless otherwise specified, test and measurement should be carried out in following condition: 如無特殊要求,試驗與測試將按以下條件進行：		
5.1	Ambient temperature 溫度	15°C ~ 35°C	
	Relative humidity 相對濕度	25% ~ 75%	
	Air pressure 氣壓	86 KPa ~ 106 KPa	
5.2	Operating temperature range 使用溫度範圍	-10°C ~ +70°C	
5.3	Storage temperature range 儲存溫度範圍	-30°C ~ +80°C	
	核 準 Approved	審 查 Q.I.Department	經 辦 者 Design Dept
	鍾振華		甘文峰

SPECIFICATIONS

Electrical characteristics

• Resistance Taper Characteristics

Resistance Taper Characteristic	Test Position (%)	$\frac{V1-2}{V1-3} \times 100\%$ (%)	$\frac{V2-3}{V1-3} \times 100\%$ (%)
A	50	10~25	—
B	50	40~60	—
C	50 (started from Term.3)	—	10~25
D	50	6~15	—
E	50	—	18~34
W	30 (±5 degree)	5~15	—
	50	40~60	—
	70 (±5 degree)	85~95	—

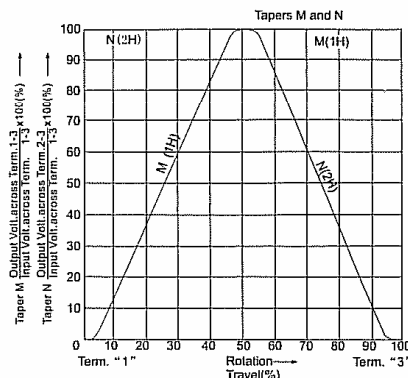
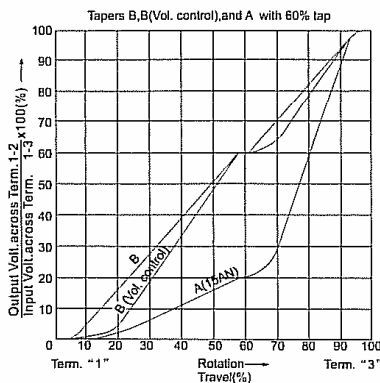
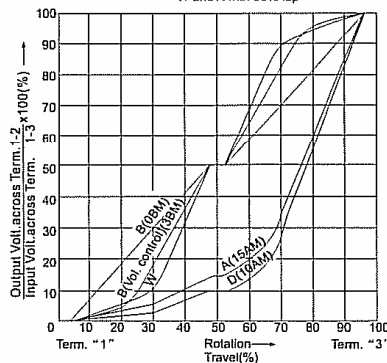
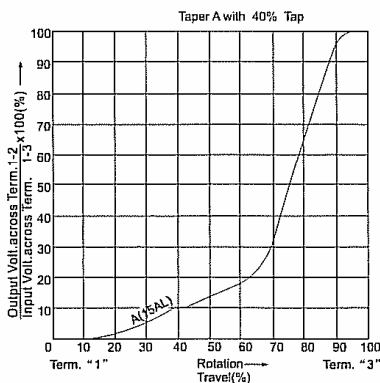
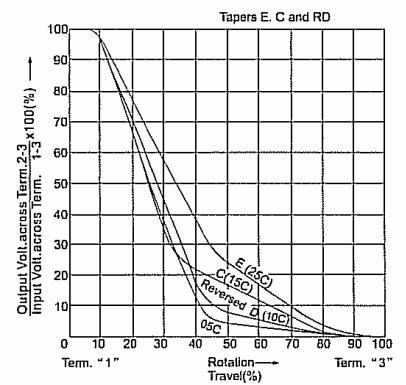
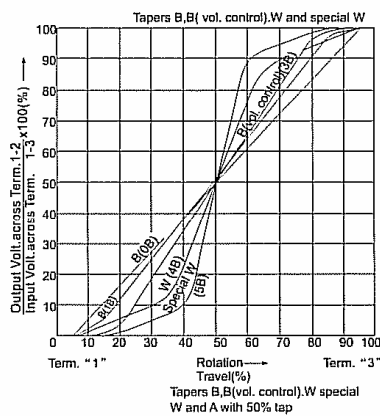
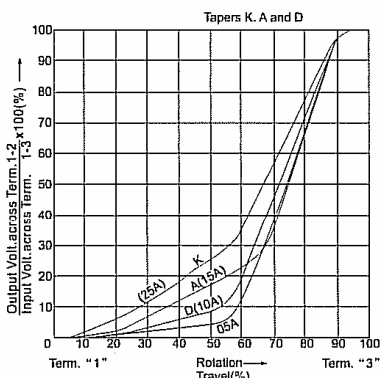

NOTE: Resistance characteristic of curve N is plotted With respect to terminal "3"