

EVC Series High Voltage DC Contactor—EVC-300 (300A Type)

Ceramic seal

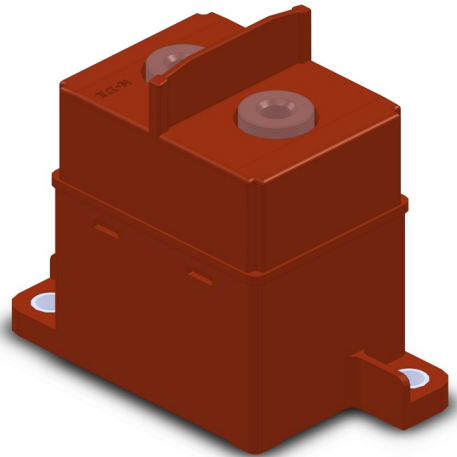

Application information

EVC series square contactor is applicable to DC systems with working voltage up to DC1500V, mainly used in new energy vehicles, charging piles, photovoltaic, energy storage and other fields. It has the characteristics of long service life, high reliability, small size and low power consumption, as well as electromagnetic compatibility, flame retardancy and rapid response.

Summarize

- Complete sealing – The contacts are in a sealed environment with low contact resistance and good stability, which can be used in harsh environments.
- Filling gas – The gas filled in the ceramic cavity helps to quickly extinguish the arc and ensure that the contact is not oxidized. The protection grade of the contact can reach IP67.
- Nonpolarity – The installation does not need to consider the current direction, which is suitable for bidirectional current flow.
- Fully RoHS compliant – More environmentally friendly.

Part number designation

EVC	-	A	-	B	-	300
Series		Contact form		Coil struc.		Current rating
		A : 1NO		B : 12VDC C : 24VDC		

Contact Specification

Contact Arrangement	1NO
Contact Material	Copper Alloy
Operation Voltage	12~1000VDC
Continue Current	300A 100mm ²
Initial Contact Resistance	< 0.5mΩ (@300A)
Current Durability (100mm ² 85°C) Refer to the current carrying curve	450A 300s 600A 120s 900A 30s 2500A 4s
Max. Breaking Current	2000A 450V 1 ops
Limit Short Circuit Current	8000A 5ms no fire or explosion

Durability

Electric Durability	±300A 750VDC 100 ops (Making & Breaking)
	±300A 1000VDC 100 ops (Breaking)
	±2000A 450VDC 1ops (Breaking)
	±1800A 500VDC 1 ops (Breaking)
	±140A 20VDC 75,000 ops (Making)

Mechanical Durability	200,000 ops
-----------------------	-------------

Note:

- 1、Electric durability tests are conducted in room temperature, operating frequency : 0.6s : 5.4s
- 2、Mechanical durability tests are conducted in room temperature, operating frequency 0.3s : 0.3s

Coil Specification

Coil Type	B	C
Rated Voltage (23°C)	12VDC	24VDC
Max. Operating Voltage (23°C)	16VDC	32VDC
Pick-up Voltage (-40~85°C)	Max. 9VDC	Max. 18VDC
Drop-out Voltage (-40~85°C)	Min. 0.6VDC	Min. 1.2VDC
Coil Resistance (23°C)	24 (±7%) Ω	96 (±7%) Ω
Rated Power (23°C)	≈6W	≈6W
Driving Mode	Single Coil	Single Coil

Mechanical Performance

Shock-Function	1/2 sine, 11ms, 196m/s ² (20G)
Shock-Destructive	1/2 sine, 11ms, 490m/s ² (50G)
Vibration	10-2000Hz, 57.9m/s ² (6G)

Application Condition

Operating Temperature	-40~85°C
Operating Humidity	5%~95%RH
Storage Temperature	10~75°C
Storage Humidity	5%~95%RH
Mounting Direction	Random
Weight	Approx. 400g

Electric Performance

Operate Time	50ms (At rated coil voltage, 23°C)
Release Time	10ms (At rated coil voltage, 23°C)
Bounce Time	5ms (At rated coil voltage, 23°C)
Insulation Resistance (Between open contact)	Before test: ≥ 1000MΩ After test: ≥ 50MΩ
Insulation Resistance (Between contact and coil)	Before test: ≥ 1000MΩ After test: ≥ 50MΩ
Dielectric Strength Leakage current ≤ 1mA (Between open contact)	Before test: 3000VAC, 50/60Hz, 1min After test: 2250VAC, 50/60Hz, 1min
Dielectric Strength Leakage current ≤ 1mA (Between contact and coil)	Before test: 3000VAC, 50/60Hz, 1min After test: 2250VAC, 50/60Hz, 1min

Current Carrying

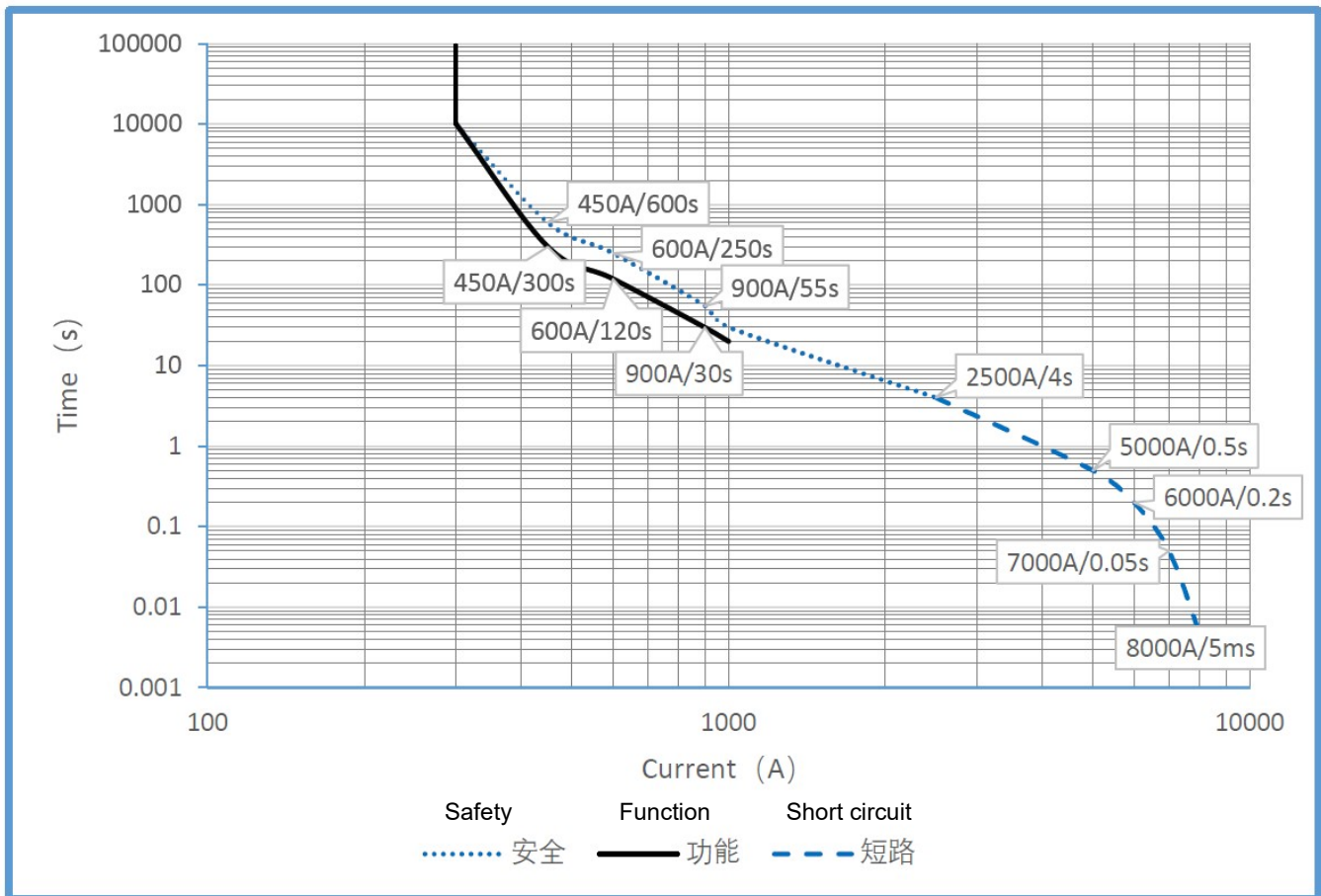

Note:

- The curve is based on the ambient temperature of 85°C, the cross-sectional area of conductor is 100mm².
- The upper limit of functional temperature rise set by this curve is 130°C, which is suitable for continuous operation.
- The upper limit of safe temperature rise set by this curve is 180°C, suitable for short-time operation and is not recommended for normal working conditions; If the temperature exceeds 180 ° C, the contactor may catch fire.
- When 2500 ~ 8000A current occurs in the circuit, the contactor contact will not be repelled. It should be matched with the fuse so that the circuit can be disconnected in time. The contactor may be stuck, but it will not ignite or explode.
- When a circuit ≥ 8000A occurs in the circuit, the contactor contact is likely to be repelled. If the fuse fails to cut off the circuit in time, the contactor may be ignited and exploded.

Order information

Order Part No.	Coil Type	Mounting Type	Others
EVC-AB-300	12VDC	Bottom Mounting	-
EVC-AC-300	24VDC	Bottom Mounting	-

Dimension

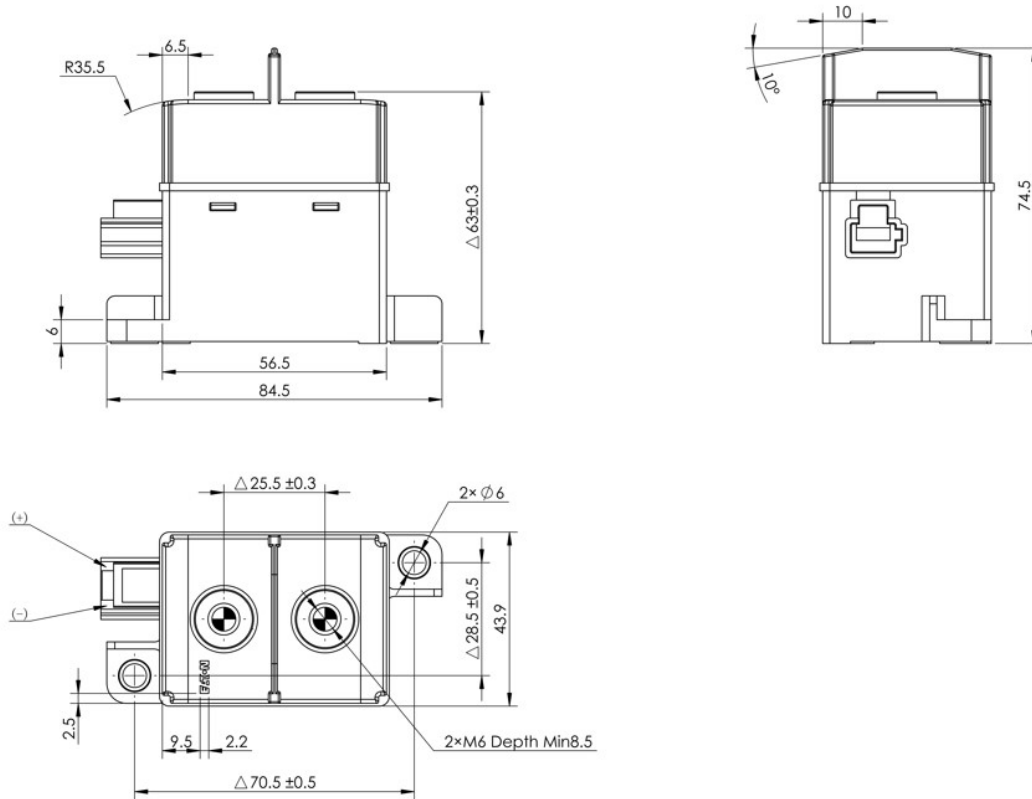

Wiring Diagram

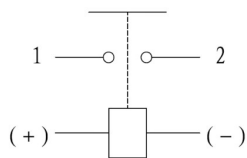

负载无极性，线圈有极性

Load has no polarity, the coil has polarity.

Note:

- Δ marked as important control dimension
- No tolerance marked, refer to:

Dimension (mm)	< 10	10~50	> 50
Tolerance (mm)	±0.3	±0.5	±0.8

- Coil mating connector recommend:

Brand	Connector	Terminal
Yazaki	7283-1020	7116-4020
THB	0435307	01175

- The products are shipped with standard installation screws, gaskets, spring washers and other accessories.
- The product coil harness is selected according to the order model.

Application considerations

- When the contactor is connected by one or more conductive copper bars, please ensure that the conductive copper bars are closely connected with the contact end surfaces (multiple copper bars need to ensure that the conductive copper bars with large current are closest to the contact end surfaces, followed by the conductive copper bars with small current), and then the flat washers, spring washers and nuts. Improper connection sequence can cause severe overheating.

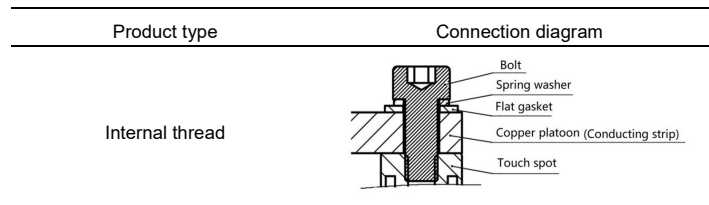

- Please avoid adhering foreign matters, grease and corrosive liquid during installation, otherwise it will cause abnormal heating at the contact end of the contactor.
- The locking torque of contactor installation shall be controlled within the range specified in the table below, which may cause thread damage. Mounting screw at the load end is an option. Please refer to the following table for installation method and other information.

Installation part of load end				Body installation part		
Installation	Torque	Breaking torque	Recommended thread engagement length	Installation	Torque	Breaking torque
M6 bolt	6N·m~8N·m	≥ 12N·m	≥ 7.5mm	M5 bolt	3.5N· m~4.5N· m	≥ 15N·m

- Please avoid installation near strong magnetic fields (around transformers, magnets, etc.) and heating objects.
- The contact of the contactor is nonpolar, and the load can be connected in any direction.
- Coil circuit of the contactor is divided into positive and negative poles, which shall be wired according to the wiring diagram.
- Paralleling freewheeling diode at the coil end of the contactor as a measure to suppress the reverse voltage will prolong the release time of the contactor and lead to the decrease of the product cutting performance. It is recommended to use bidirectional zener diode and TVs tube with a clamping voltage of more than 1.5 times the rated voltage of the coil to suppress the reverse overvoltage of the coil.
- When the contactor is applied in the capacitive load circuit, please pay attention to taking pre charging and other measures. It is recommended that the closing pressure difference of the contactor be controlled within 20V. If pre charging measures are not taken, contact adhesion may be caused.
- When the contactor is applied in the inductive load circuit, it is recommended to install surge absorption device in parallel with the inductive load. If no measures are taken, the cut-off performance of the contactor may be reduced.
- Please avoid collision or falling of the contactor during use, installation or transportation. In order to maintain the performance of the contactor, it is not recommended to use the contactor after impact or falling.
- The contact cavity of the contactor is filled with protective gas, and there is internal gas penetration along with the change of contact temperature. It is strictly prohibited to put the relay in the use temperature range (- 40 ~ + 85 ° C) exceeding the product for a long time.
- For information on matching application of contactors and fuses, please contact Bussmann technical support team.

Disclaimer of warranties and limitation of liability

The information, recommendations, descriptions, and safety notations in this document are based on Eaton Corporation's ("Eaton") experience and judgment, and may not cover all contingencies. If further information is required, an Eaton sales office should be consulted. Sale of the product shown in this literature is subject to the terms and conditions outlined in appropriate Eaton selling policies or other contractual agreement between Eaton and the purchaser. There are no understandings, agreements, warranties, expressed or implied, including warranties of fitness for a particular purpose or merchantability, other than those specifically set out in any existing contract between the parties. any such contract states the entire obligation of Eaton. The contents of this document shall not become part of or modify any contract between the parties. In no event will Eaton be responsible to the purchaser or user in contract, in tort (including negligence), strict liability, or otherwise for any special, indirect, incidental, or consequential damage or loss whatsoever, including but not limited to damage or loss of use of equipment, plant or power system, cost of capital, loss of power, additional expenses in the use of existing power facilities, or claims against the purchaser or user by its customers resulting from the use of the information, recommendations, and descriptions contained herein. The information contained in this manual is subject to change without notice.