

REVISION RECORD				
REV	ECN	DESCRIPTION	DRFT	DATE

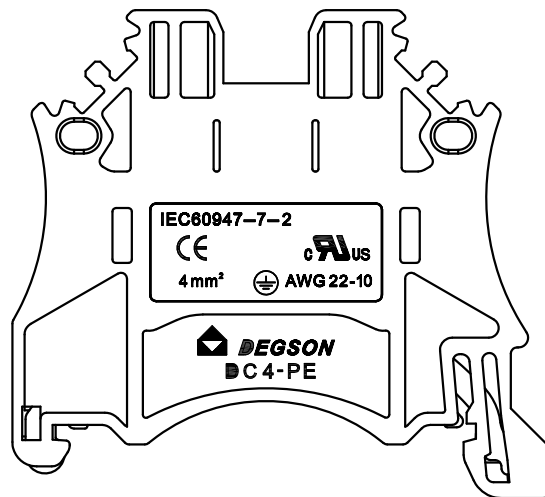
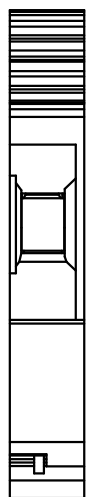
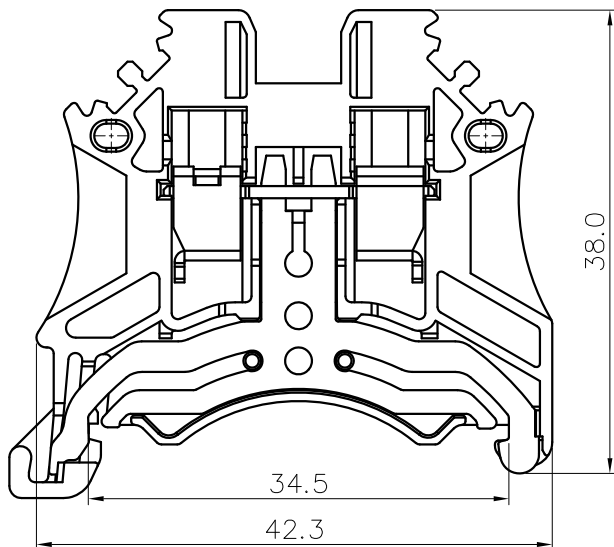
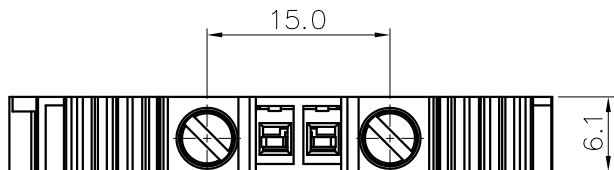

NOTES1:

- UL Standard
- 1.Torque value : M3 , 4.43Lb.in
- 2.Wire range : 22~10AWG

IEC Standard

- 1.Torque value : M3 , 0.5N·m
- 2.Wire range : 0.5~4mm²

NOTES2:

- 1.Dimension shall be interpreted per ASME Y14.5-2009
- 2.Pitch : 6.1mm, Poles : N=01P
- 3.Stripping length : 8~9mm
- 4.Operating temperature: -40°C~+105°C
- 5.Undimensioned tolerances:

Pitch Range In mm	Nominal Dimension Range In mm						0.1/10	
	Over 6 TO 10	Over 10 TO 24	Over 30 TO 60	Over 60 TO 100	Over 100 TO 150	Over 150		
±0.15	±0.20	±0.30	±0.30	±0.50	±0.70	±1.00	±1.30	±2'

6.RoHS Compliance

DC4-PE - 01P - 1C - 00A (H)
 (Series No.) (Poles) (Single Pitch) (Color):1.(Grey)
 2.(Blue)
 3.(Black)
 4.(Green)
 5.(Orange)
 6.(Red)
 7.(Transparent)
 8.(Yellow)
 9.(White)
 C.(Yellow and green)
 (RoHS)
 00A-(Standard)

DETACHED LISTS	PART NO.:	/			宁波高松电子有限公司 NINGBO DEGSION ELECTRICAL CO., LTD		
	APPD:	/				NAME:	
	CHKD:	/			DC4-PE-01P-1C-00A(H)		
	DRFT:	/			TITLE: CUSTOMER DRAWING	REV	DO
	THIRD ANGLE PROJECTION		DRAWING NO.:	/		SHEET	1/1
		MM (INCH)	DO NOT SCALE DRAWING	SCALE	1:1		