

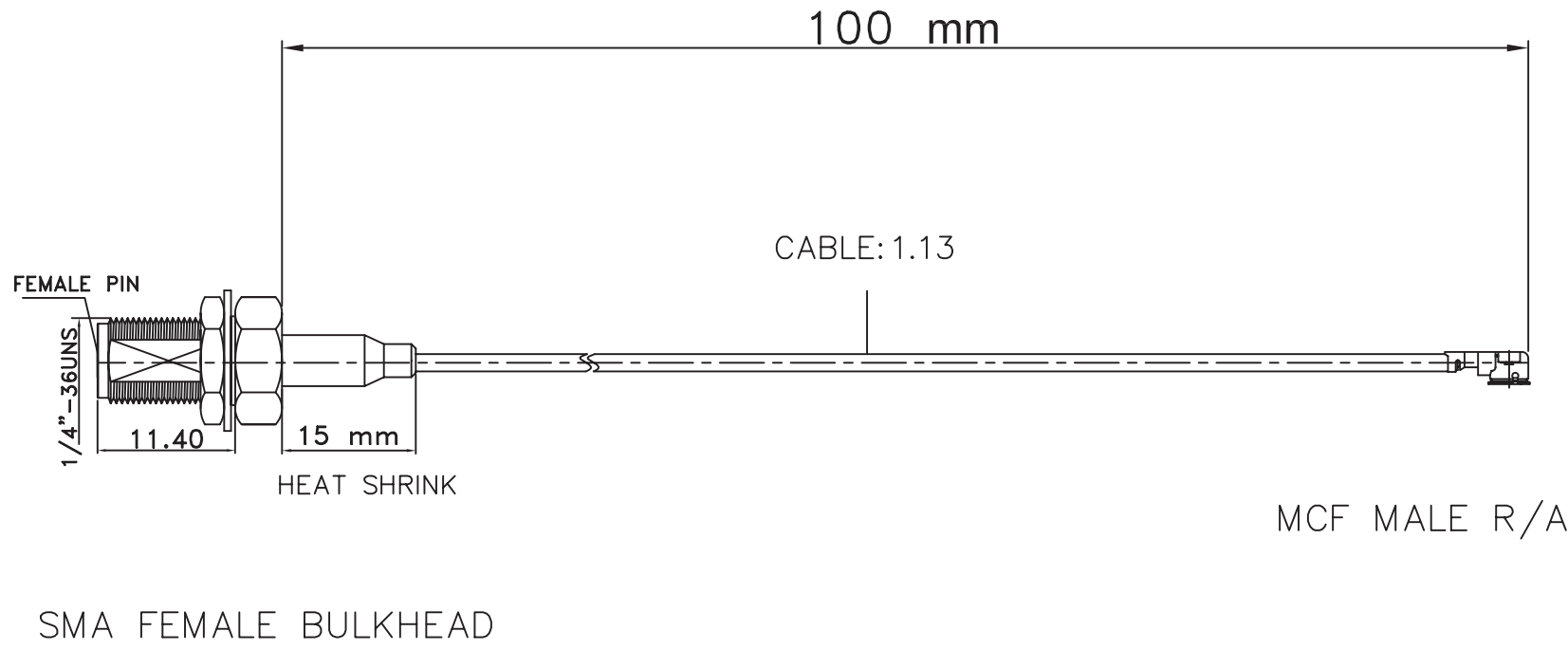

REV	DESCRIPTION	DRAWN	DATE



UNLESS OTHERWISE SPECIFIED					* MAJOR DIMENSION				APPROVED		 <small>CHANG HONG TECHNOLOGY Co., Ltd.</small>				
NO	Description	Q'ty	Material	Finish	UNLESS OTHERWISE NOTED TOLERANCES 0.5-6=±0.2 6-30=±0.4 30-120=±0.6 120-315=±1.0 ANGLES=±1°				CHECKED	DRAWN					
3	MCF MALE R/A	1	BRASS	GOLD	1.REMOVE ALL BURRS. 2.BREAK ALL CONNERS & EDGES CO.15 MAX. 3.CHAMFER 1ST & LAST THREADS 45°. 4.DIAMETERS ON COMMON CENTERS. TO BE CONCENTRIC WITHIN 0.1 T.I.R. 5.ALL DIMENSIONS ARE AFTER PLATING.				andrew		TITLE		REV		
2	CABLE: 1.13	1									DRAWING NO.			A	
1	SMA-02-71-I-TGG	1	BRASS	GOLD							027113MCF-100				
NO	Description	Q'ty	Material	Finish					SCALE	5/1	UNIT	MM	DRAWN DATE	FILE NO.	